

ROLL TO WIN CRAPS

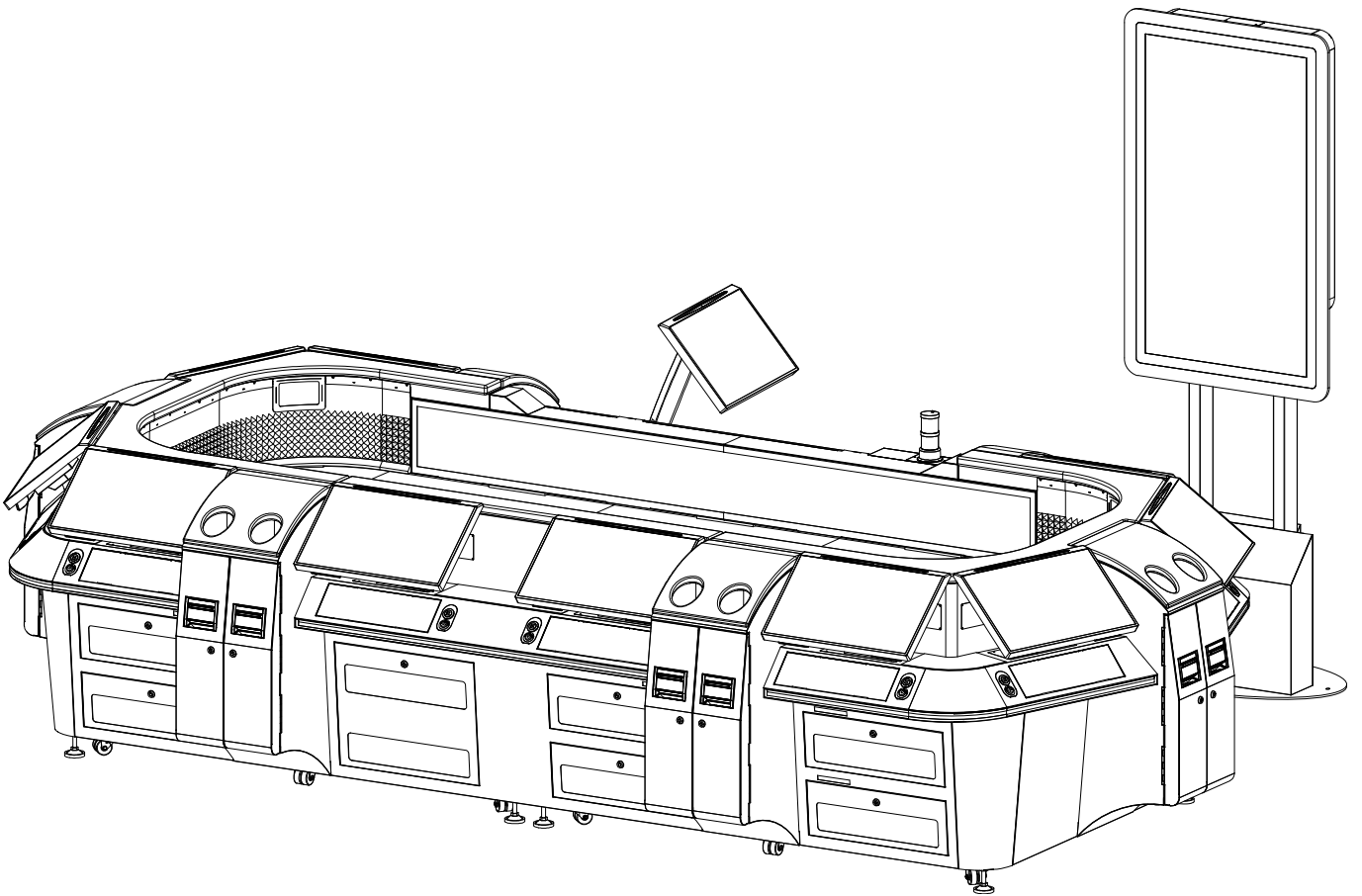

Table of Contents

	Page
General Information	
Introduction	1
Technical Support	1
Copyright	1
Safety Instructions	
Definition of Safety Vocabulary	2
Installation	3
Replacement of Lithium Batteries	3
Disposal of Lithium Batteries	3
Environmental Specifications	4
Grounding	4
Others	4
Chapter 1: Major Components	
1. 1 Appearance of Whole Machine	1-1
1. 2 Outside View of Center Unit	1-2
1. 3 Inside View of Center Unit	1-4
1. 4 Outside View of Controller Unit (Main / Signage / Station)	1-6
1. 5 Inside View of Controller Unit (Main / Signage / Station)	1-7
1. 6 Outside View of History Display Unit(Optional)	1-8
1. 7 Inside View of History Display Unit(Optional)	1-9
1. 8 Appearance of Player Partition Unit(Optional)	1-10
1. 9 Appearance of Dealer Partition Unit(Optional)	1-10
Chapter 2: Unpacking and Inspection	
2. 1 Unpacking and Inspection	2-1
Chapter 3: Installation	
3. 1 Cabinet Dimensions	3-1
3. 2 Installing the Machine	3-2
3. 2. 1 Installing the Center Unit	3-5
3. 2. 2 Assembling the Bottom LED Cover Units	3-10
3. 2. 3 Hardware setting for whole the Machine	3-18
3. 2. 3. 1 Center Unit	3-18
3. 2. 3. 2 Controller Units (Signage, Main, Station)	3-20
3. 2. 4 Installing the Controller Units	3-25
3. 2. 5 Installing the Field LED Unit	3-36

3. 2. 6	Precheck of the Field LED Unit	3-52
3. 2. 7	Installing the Wall Unit	3-53
3. 2. 8	Connecting the Wall Unit	3-63
3. 2. 9	Precheck of the Wall LED Unit	3-78
3. 2. 10	Installing the Ticket Printer and Validator Unit – Single type	3-79
3. 2. 11	Installing the Ticket Printer and Validator Unit – Double type	3-89
3. 2. 12	Installing the Dealer Terminal Unit	3-97
3. 2. 13	Preparing the Player Terminal Unit	3-107
3. 2. 14	Installing the Player Terminal Unit	3-110
3. 2. 15	Connecting the Center Unit to the Power Source	3-113
3. 2. 16	Installing the History Display Unit(Optional)	3-115
3. 2. 17	Installing the External monitors	3-127
3. 2. 17. 1	[Betting status] for Surveillance Monitor	3-128
3. 2. 17. 2	[GAME Field and WALL Display] for Audience Live viewing Monitor	3-130
3. 2. 18	Installing the Doors onto the Center Unit	3-132
3. 2. 19	Checking and Setting	3-133
3. 2. 19. 1	Checking Operation of Center Unit	3-134
3. 2. 19. 2	Checking Operation of Player Terminal	3-139
3. 2. 19. 3	Verifying Operation of Whole Machine	3-143
3. 2. 20	Installing the Field Bumps or the Field Fabric	3-144
3. 2. 20. 1	Field Bumps Specification	3-144
3. 2. 20. 2	Field Fabric Specification	3-145
3. 2. 21	Installing the Dice tilt rubber	3-147
3. 2. 22	Installing the Player Partition Unit	3-148
3. 2. 23	Installing the Dealer Partition Unit	3-153

Chapter 4: Machine Specifications

4. 1	Cabinet Code(MODEL#)	4-1
4. 2	Overall Dimension	4-1
4. 3	Weight	4-1
4. 4	Electrical Specifications	4-1
4. 5	Environment	4-4
4. 6	Bills Capacity	4-4



General Information

Introduction

This manual is intended to provide information regarding machine operation for operators, owners, and qualified maintenance/service personnel.

It is strongly recommended that this manual be read thoroughly before starting up the machine. Please keep this manual at hand to be used whenever necessary.

Technical Support

INTERBLOCK Luxury Gaming Products d.d., INTERBLOCK ASIA PACIFIC Pty Ltd, INTERBLOCK CASINO PRODUCTS CANADA Inc., INTERBLOCK ASIA PACIFIC Pty Ltd, INTERBLOCK USA L.C. are all dedicated to providing high quality service and maintenance. Please feel free to contact your local distributor office at any time. (See back page for contact listings)

Copyright

©2024 Interblock d.o.o. All rights reserved.

The information in this document is confidential. Reproduction in whole or in part on any medium without the express permission of Interblock d.d. is strictly prohibited.

This manual may be subject to change without prior notice.

Safety Instructions

Definition of Safety Vocabulary

The words DANGER, WARNING, and CAUTION are used in this manual to indicate hazard levels.

DANGER!

The DANGER mark warns of immediate hazards, which WILL result in severe personnel injury or death.

WARNING!

The WARNING mark warns of immediate hazards, which may result in severe personnel injury or death.

CAUTION!

The CAUTION mark warns of hazards or unsafe practices, which may result in minor personnel injury or product/property damage.

CALL SERVICE IMMEDIATERY!

This message implies that the operator is recommended to contact the Customer Technical Support. (See back page for contact listings.)

NOTE:

The NOTE mark brings to attention important operation points.

Installation

WARNING!

To prevent an accident or a fire;

- ◇ Install the machine on flat, stable, well-constructed floor.
- ◇ Keep the machine away from direct sunlight.
- ◇ Keep the machine away from dust.
- ◇ Keep the machine away from water and other liquids.
- ◇ Do not install the machine outdoors.
- ◇ Keep the machine away from vibration.
- ◇ Keep the machine away from dangerous articles.
- ◇ Keep the machine away from disaster prevention facilities. (e.g. emergency exits/stairs, fire hydrants, fire extinguishers)
- ◇ **If the Projector is installed, please use the machine in an ambient with a temperature below 30°C. If the ambient temperature exceeds 30°C, the security function of the Projector may put it into a light off status.**

Replacement of Lithium Batteries

CAUTION!

Risk of Explosion.

When exchanging the lithium batteries, use an officially provided lithium battery.

Risk of Explosion if lithium battery is Replaced by an Incorrect type.

Disposal of Lithium Batteries

WARNING!

Risk of Injury or Fire.

Proper care is necessary with the disposal of lithium batteries. Improper disposal may result in the heating or ignition of the batteries, which may cause personal injury or fire. CR Coin Lithium Batteries contain Perchlorate material – special handling may apply.

Lithium batteries contain flammable substances (e.g. lithium metal and organic solvents). Electric power may remain in used batteries. Wrap the + and – electrodes with nonconductive material to prevent short-circuiting.

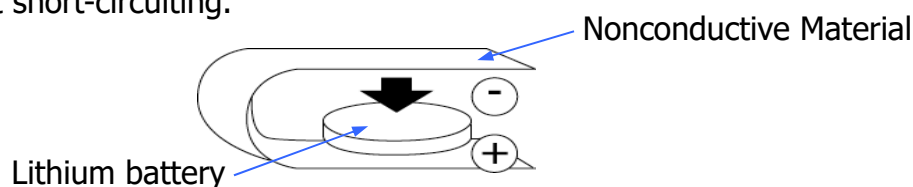

Environmental Specifications

Refer to "**Machine Specifications**".

Grounding

The machine must be grounded to prevent current leakage.



WARNING!

Risk of Electric Shock. The warranty is not valid for accidents (including failures) caused by improper grounding.

Others



WARNING!

The machine should never be modified in any way.

Modification may cause accident or failure.

The warranty is not valid for accidents (including failures) caused by modification.

- ◇ Only qualified personnel shall assemble, install, maintain, inspect, and/or enact any troubleshooting measures to the machine.
- ◇ Do not sit, stand or put heavy objects on the machine. A dented machine may cause malfunctioning.
- ◇ When smoke and/or an unknown malfunction is detected, immediately turn off the power switches and then turn off the power source breakers in that order.
- ◇ Before servicing the machine, turn off the power switches to prevent electricity-related accidents and hazards.
- ◇ Never use chemical dusters, paint thinner, benzene, alcohol, or synthetic detergent for cleaning the machine. Damage may be caused to the machine surface.
- ◇ Electrostatic discharges may damage the internal components of the machine. Anti-static measures (e.g. touching a metal door knob, use of non-static gloves) are necessary when accessing the inside of the cabinet.
- ◇ This machine is for use in commercial areas. Use in residential areas is prohibited.

Chapter 1

Major Components

1. 1: Appearance of Whole Machine (Front View)

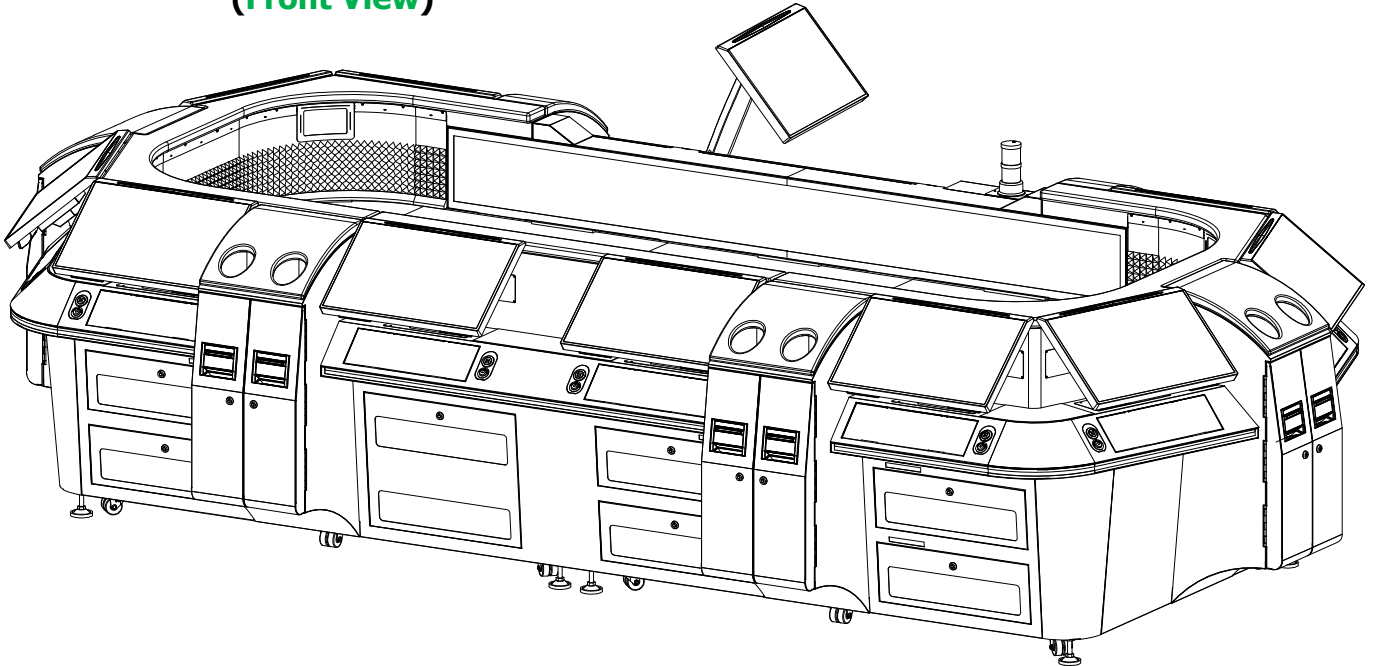

(Rear View)

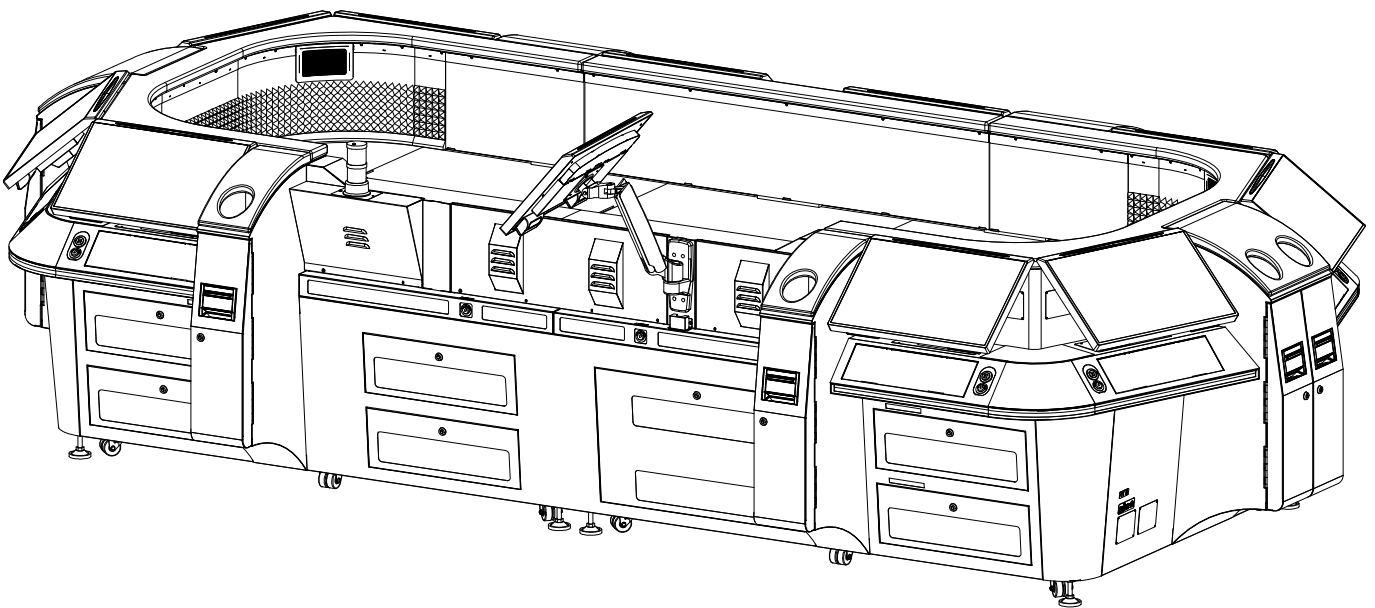

1. 2: Outside View of Center Unit
(Front View)

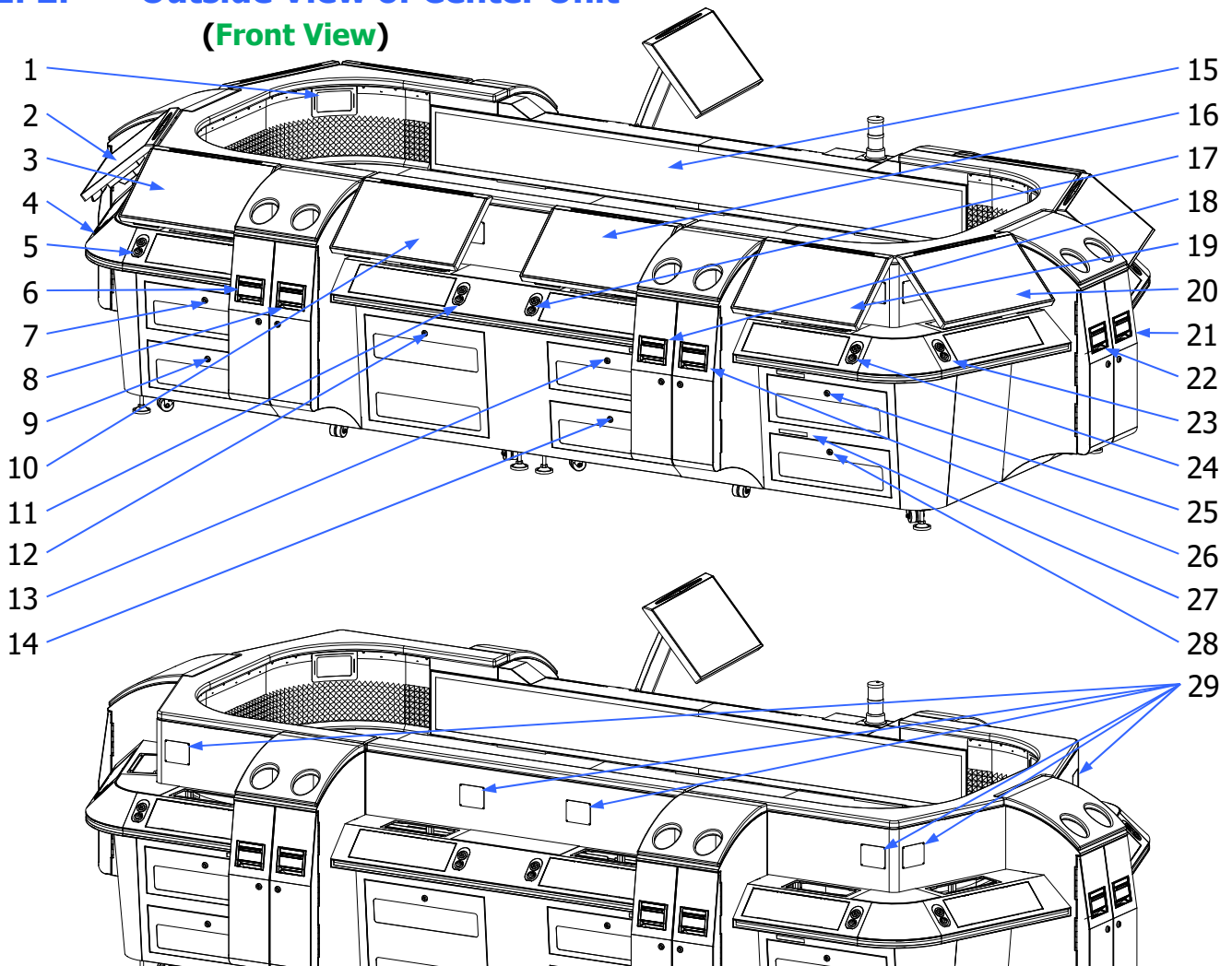

- | | |
|--|---|
| 1. Speaker | 15. Wall LED |
| 2. No.8 Player Terminal | 16. No.5 Player Terminal |
| 3. No.7 Player Terminal | 17. No.5 Terminal RESET/AUDIT Key Switch |
| 4. No.8 Terminal RESET/AUDIT Key Switch | 18. No.5 Terminal BILL Ticket Entry & Chute |
| 5. No.7 Terminal RESET/AUDIT Key Switch | 19. No.4 Player Terminal |
| 6. No.7 Terminal BILL Ticket Entry & Chute | 20. No.3 Player Terminal |
| 7. No.7 Front Door Lock | 21. No.2 Terminal Ticket Entry & Chute |
| 8. No.6 Terminal Ticket Entry & Chute | 22. No.3 Terminal Ticket Entry & Chute |
| 9. No.8 Front Door Lock | 23. No.3 Terminal RESET/AUDIT Key Switch |
| 10. No.6 Player Terminal | 24. No.4 Terminal RESET/AUDIT Key Switch |
| 11. No.6 Terminal RESET/AUDIT Key Switch | 25. No.3 Front Door Lock |
| 12. Controller Door Lock | 26. No.4 Terminal Ticket Entry & Chute |
| 13. No.5 Front Door Lock | 27. No.4 Terminal Counter |
| 14. No.6 Front Door Lock | 28. No.4 Front Door Lock |
| | 29. Serial Plate |

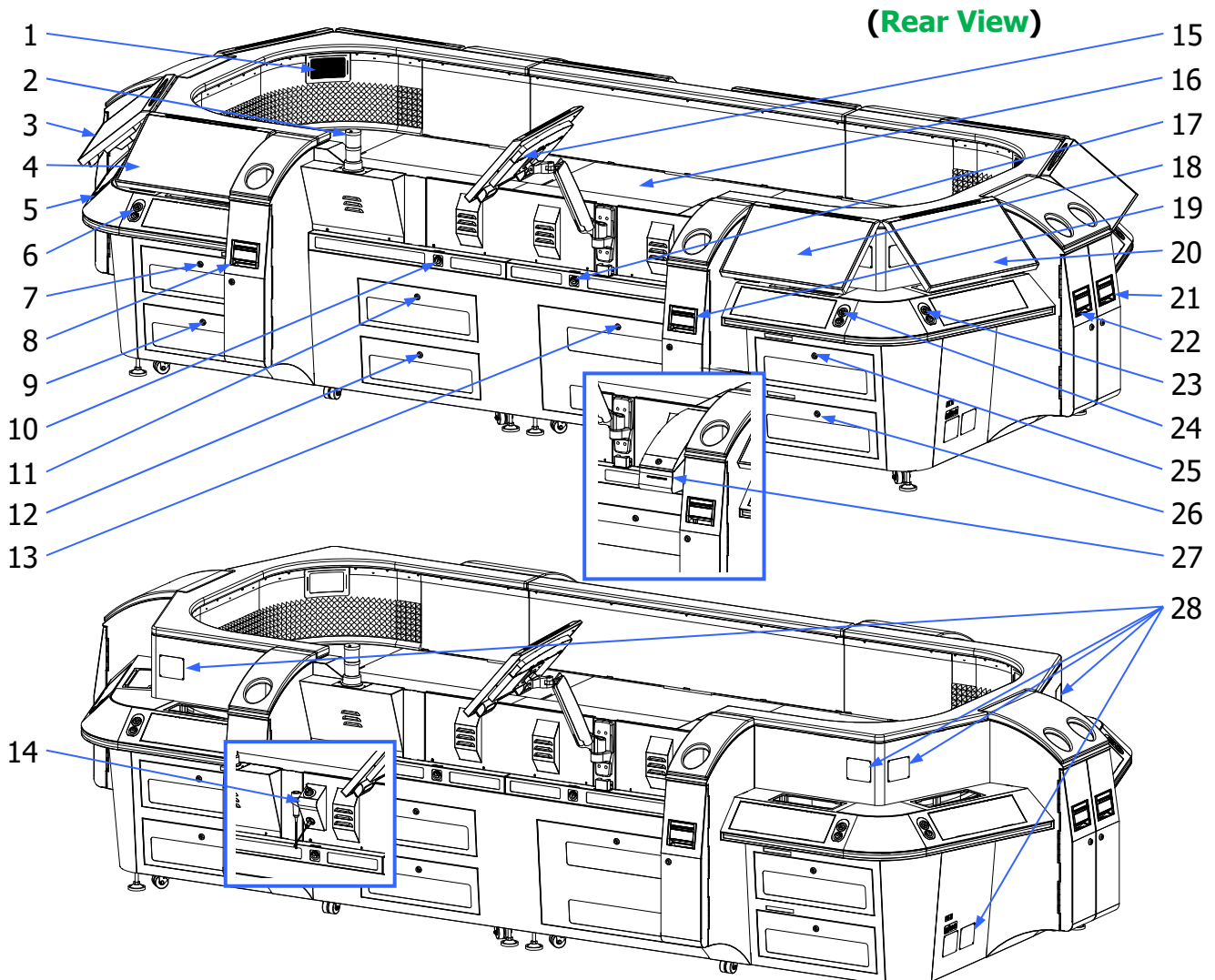

- | | |
|---|---|
| 1. Speaker | 15. Dealer Terminal |
| 2. Tower Light(When choosing Option-1) | 16. Field LED |
| 3. No.2 Player Terminal | 17. Main Controller Unit RESET/AUDIT Key Switch |
| 4. No.1 Player Terminal | 18. No.10 Player Terminal |
| 5. No.2 Terminal RESET/AUDIT Key Switch | 19. No.10 Terminal Ticket Entry & Chute |
| 6. No.1 Terminal RESET/AUDIT Key Switch | 20. No.9 Player Terminal |
| 7. No.1 Front Door Lock | 21. No.8 Terminal Ticket Entry & Chute |
| 8. No.1 Terminal Ticket Entry & Chute | 22. No.9 Terminal Ticket Entry & Chute |
| 9. No.2 Front Door Lock | 23. No.9 Terminal RESET/AUDIT Key Switch |
| 10. Signage Controller Unit RESET/AUDIT Key Switch | 24. No.10 Terminal RESET/AUDIT Key Switch |
| 11. Front Signage Door Lock | 25. No.9 Front Door Lock |
| 12. Front Main Door Lock | 26. No.10 Front Door Lock |
| 13. Power Door Lock | 27. Tipping System(Optional) |
| 14. Operation Stop Key(Optional)
Terminal Operation Button(Optional) | 28. Serial Plate |

**1. 3: Inside View of Center Unit
(Front View)**

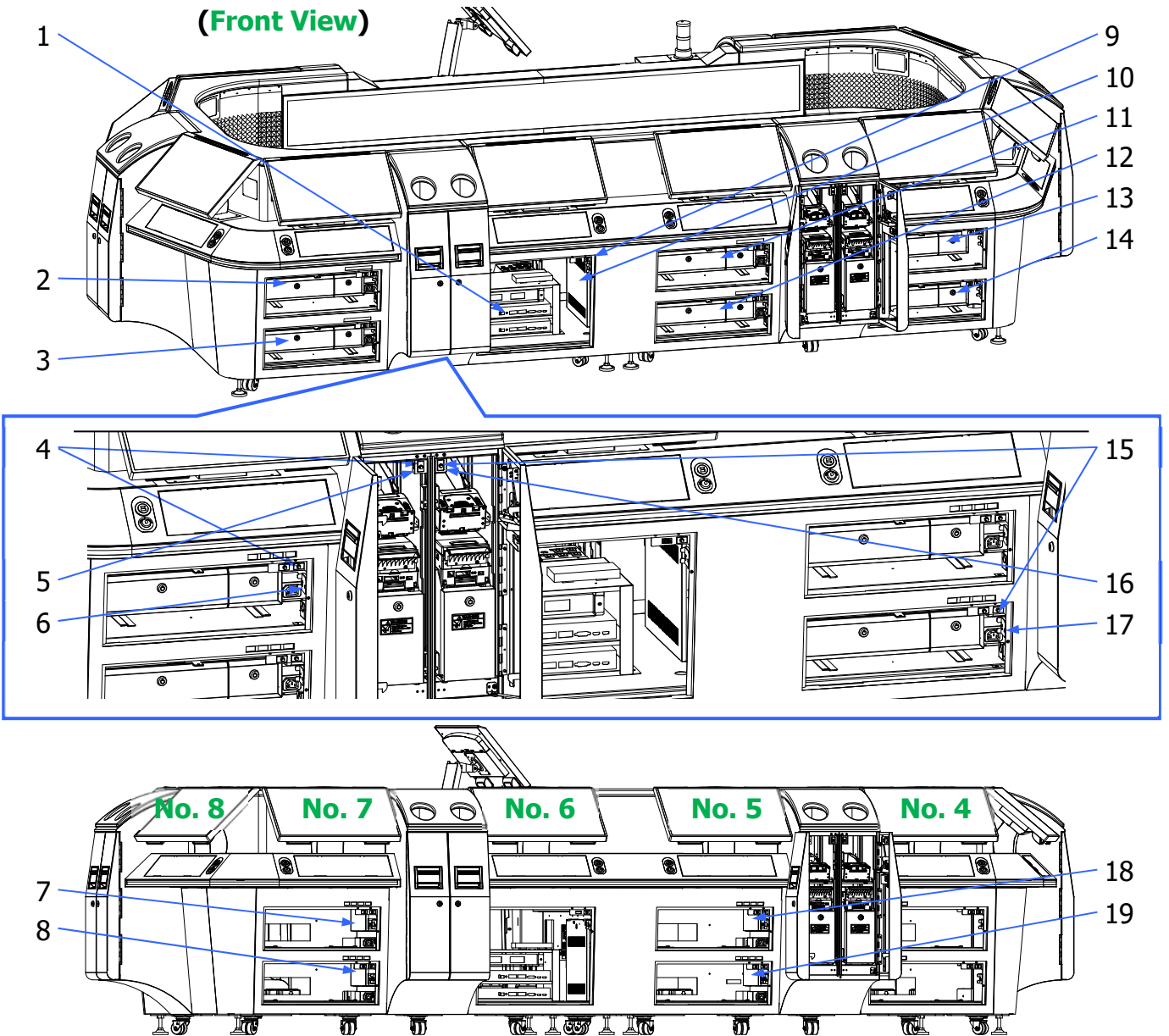

- | | |
|---|--|
| 1. LED Controller Unit | 9. Controller Door Switch and Sensor |
| 2. No.7 Station Controller Unit | 10. IO Box |
| 3. No.8 Station Controller Unit | 11. No.5 Station Controller Unit |
| 4. No.7 Front and BILL Door Switch | 12. No.6 Station Controller Unit |
| 5. No.7 BILL Door Switch(Optical Sensor) | 13. No.3 Station Controller Unit |
| 6. No.7 Front Door Switch(Optical Sensor) | 14. No.4 Station Controller Unit |
| 7. No.7 Terminal Sub IO Case | 15. No.6 Front and BILL Door Switch |
| 8. No.8 Terminal Sub IO Case | 16. No.6 BILL Door Switch(Optical Sensor) |
| | 17. No.6 Front Door Switch(Optical Sensor) |
| | 18. No.5 Terminal Sub IO Case |
| | 19. No.6 Terminal Sub IO Case |

(Rear View)

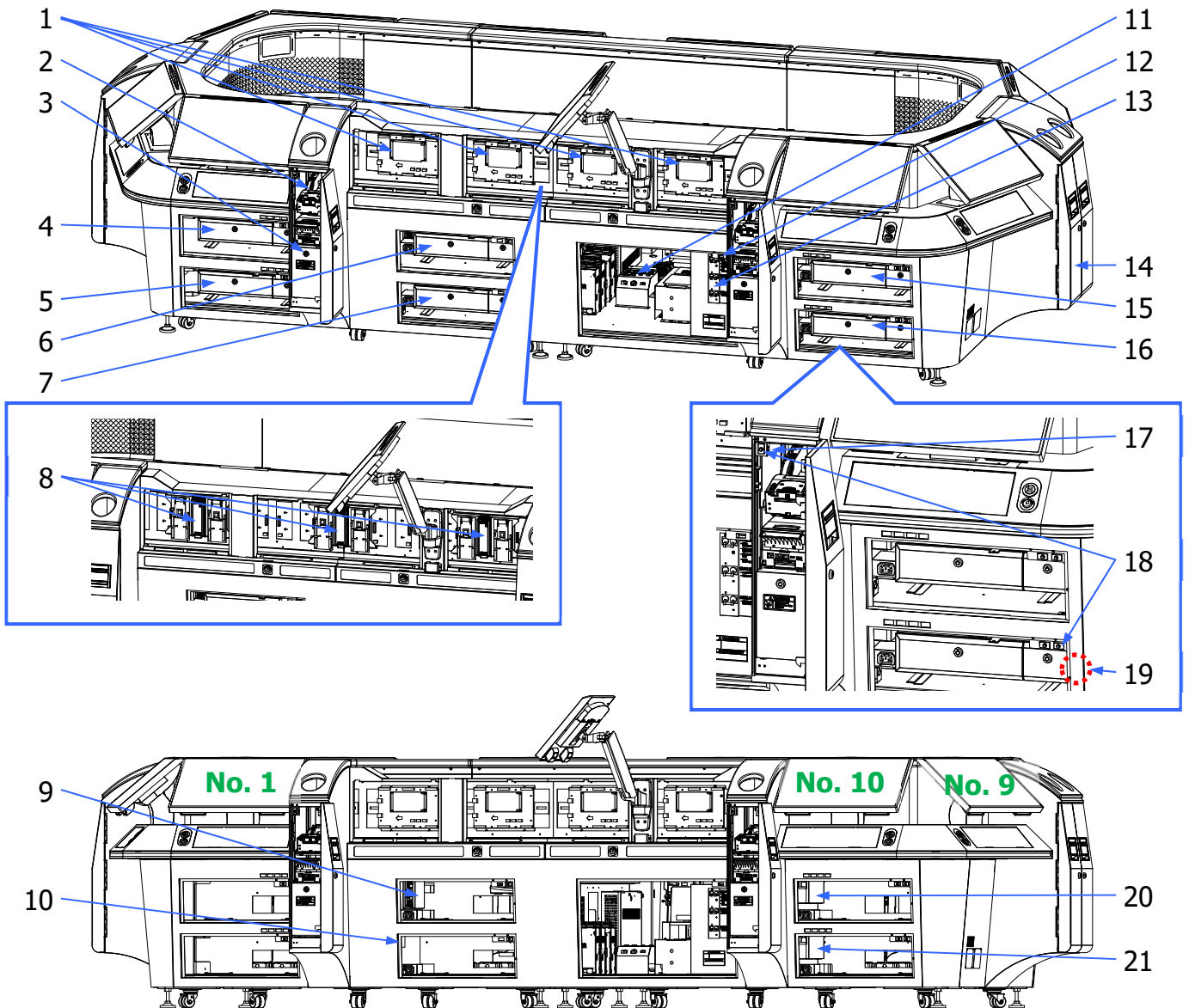

- | | |
|--|---|
| 1. Wall LED Controller PCB(4 pcs type) | 11. Breaker Unit |
| 2. Ticket Printer | 12. Power Door Switch and Sensor |
| 3. Stacker Door Lock | 13. Power Switch Box |
| 4. No.1 Station Controller Unit | 14. No.9 Terminal BILL Door |
| 5. No.2 Station Controller Unit | 15. No.9 Station Controller Unit |
| 6. Signage Controller Unit | 16. No.10 Station Controller Unit |
| 7. Main Controller Unit | 17. No.10 BILL Door Switch(Optical Sensor) |
| 8. Wall LED Controller PCB(3 pcs type) | 18. No.10 Front and BILL Door Switch |
| 9. AMP Case | 19. No.10 Front Door Switch(Optical Sensor) |
| 10. EDID Emulator | 20. No.9 Terminal Sub IO Case |
| | 21. No.10 Terminal Sub IO Case |

1. 4: Outside View of Controller Unit (Main / Signage / Station)

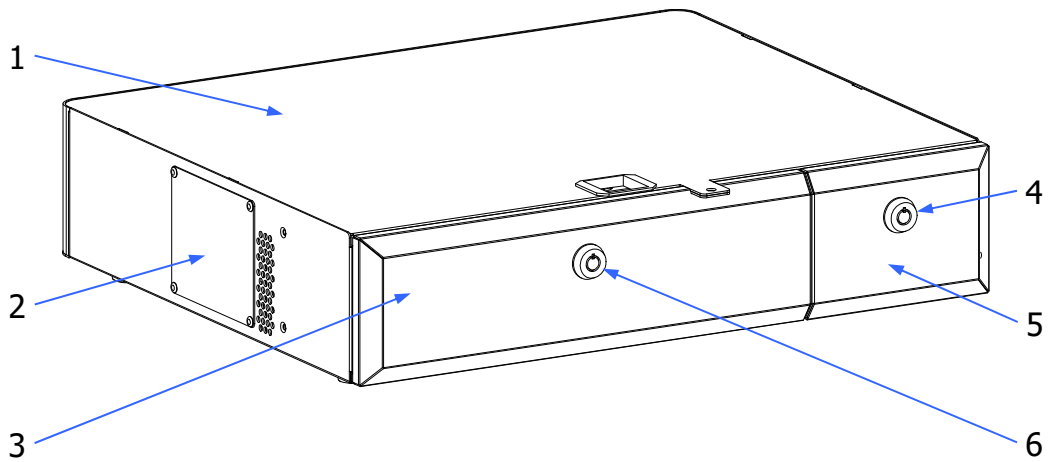

- | | |
|-------------------------------|-----------------------|
| 1. Side Slide Door(Top Cover) | 4. Security Door Lock |
| 2. Serial Plate | 5. Security Door |
| 3. Main Door | 6. Main Door Lock |

1. 5: Inside View of Controller Unit (Main / Signage / Station)

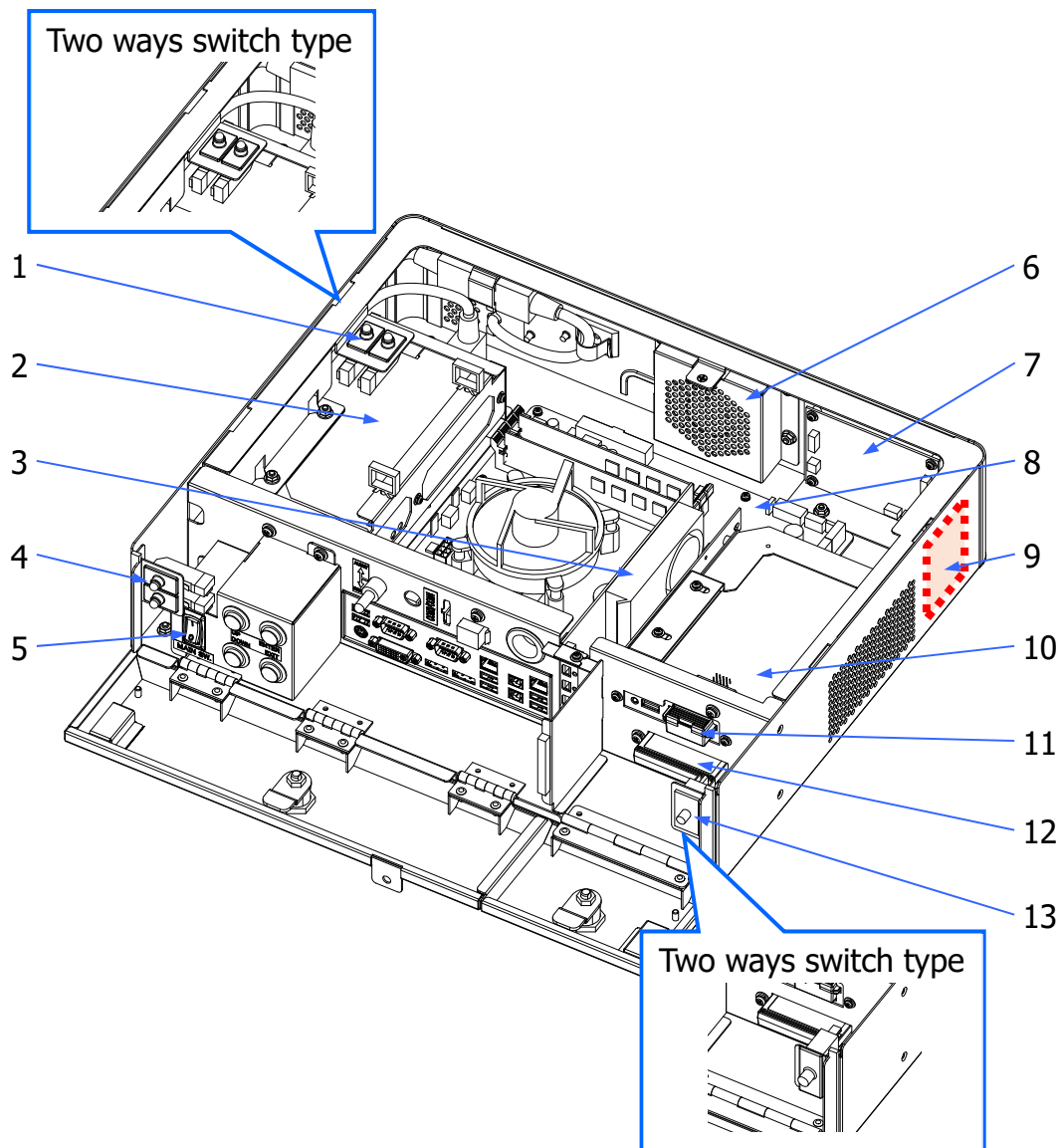

- | | |
|---|--|
| 1. Side Slide Door(Top Cover) Switch | 6. Security Box Fan(Cabinet Fan) |
| 2. Power Supply | 7. AX-GEN IO PCB
(Only Station Controller Unit) |
| 3. Video Card PCB
(Except Station Controller Unit) | 8. AP-X Motherboard PCB |
| 4. Main Door Switches | 9. Buck up SSD PCB
(Except Signage Controller Unit) |
| 5. Power Switch(Do not use) | 10. AX-GMEM PCB |
| | 11. AX-GAL PCB
(Except Signage Controller Unit) |
| | 12. SSD PCB |
| | 13. Security Door Switch |

1. 6: Outside View of History Display Unit(Optional)

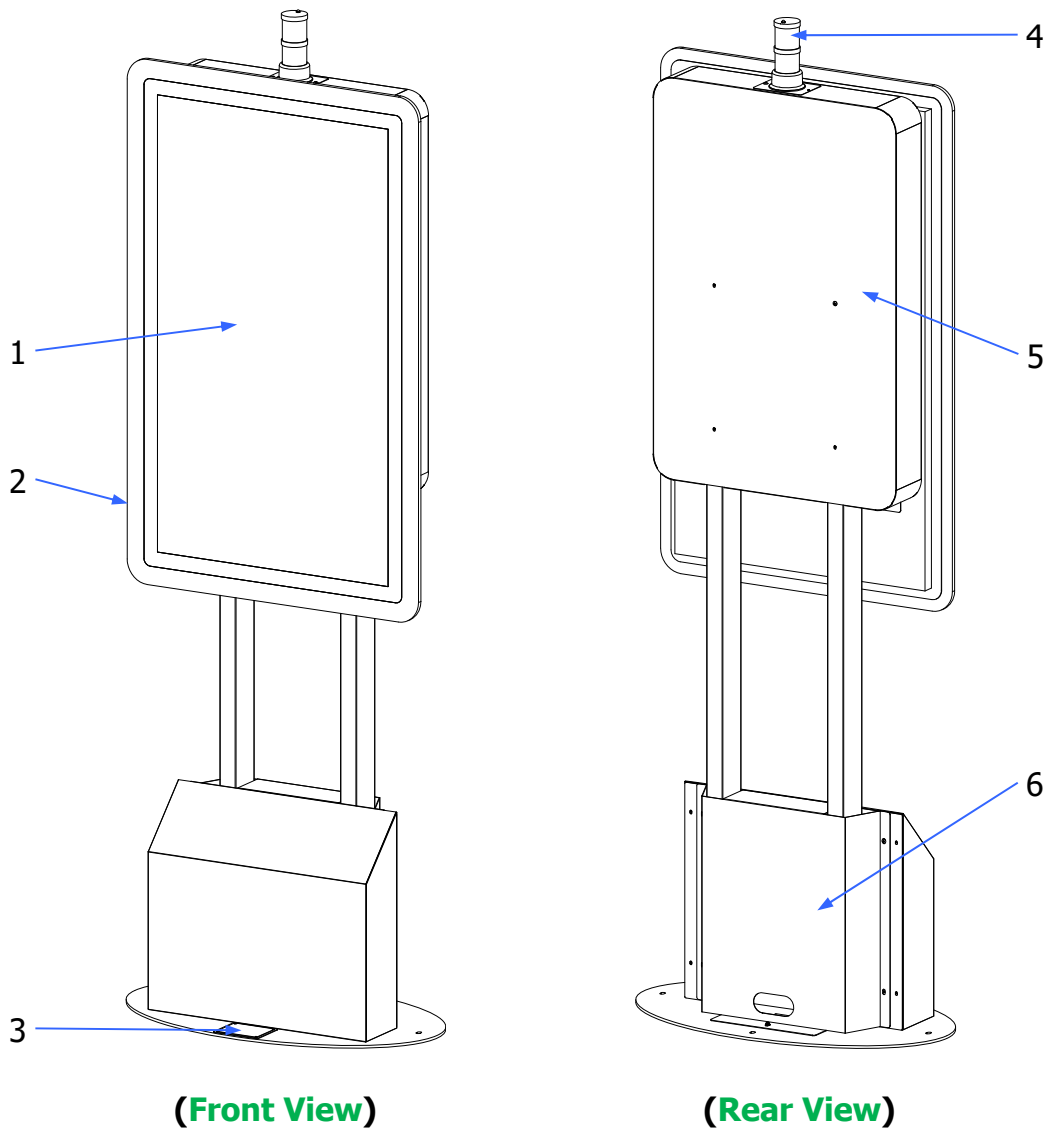

1. LCD Monitor
2. History LED
3. Serial Plate

4. Tower Light(Optional)
5. Top Cover
6. Bottom Back Cover(Cover A)

1. 7: Inside View of History Display Unit(Optional)

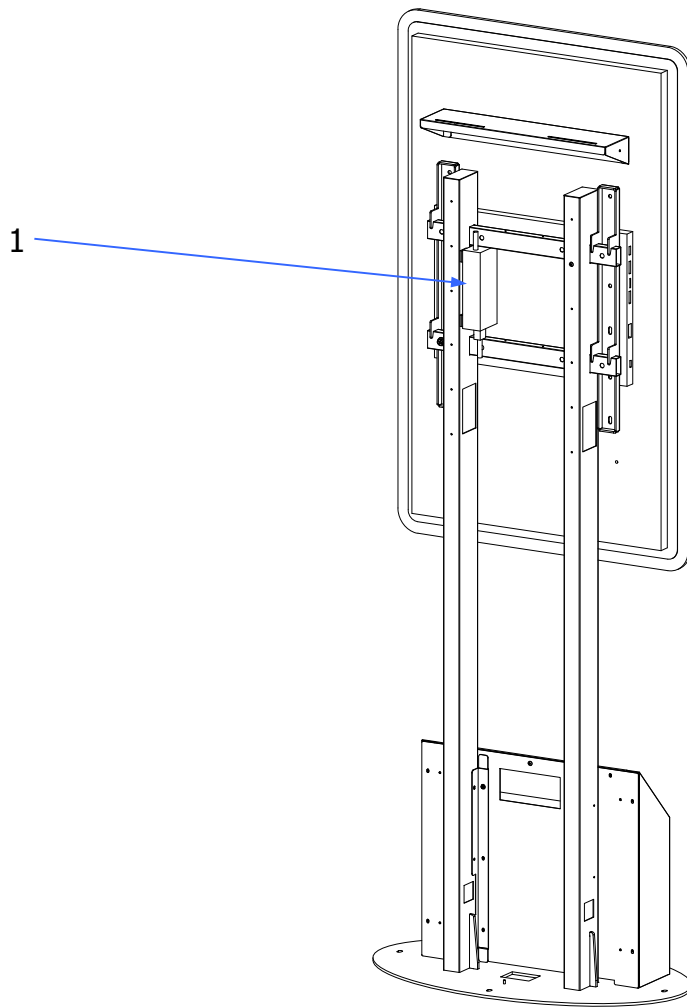

1. Switching Power Adapter

1. 8: Appearance of Player Partition Unit(Optional)
(Front View)

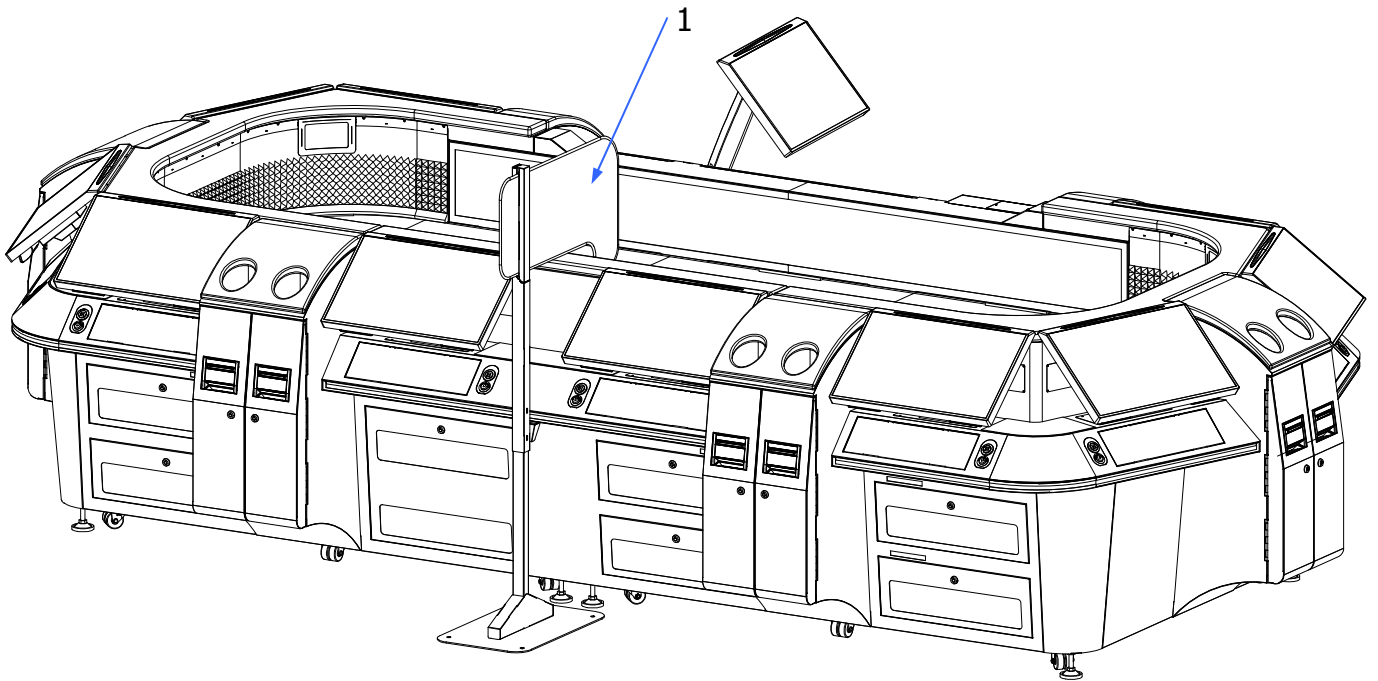

- 1. Player Partition Unit

1. 9: Appearance of Dealer Partition Unit(Optional)
(Rear View)

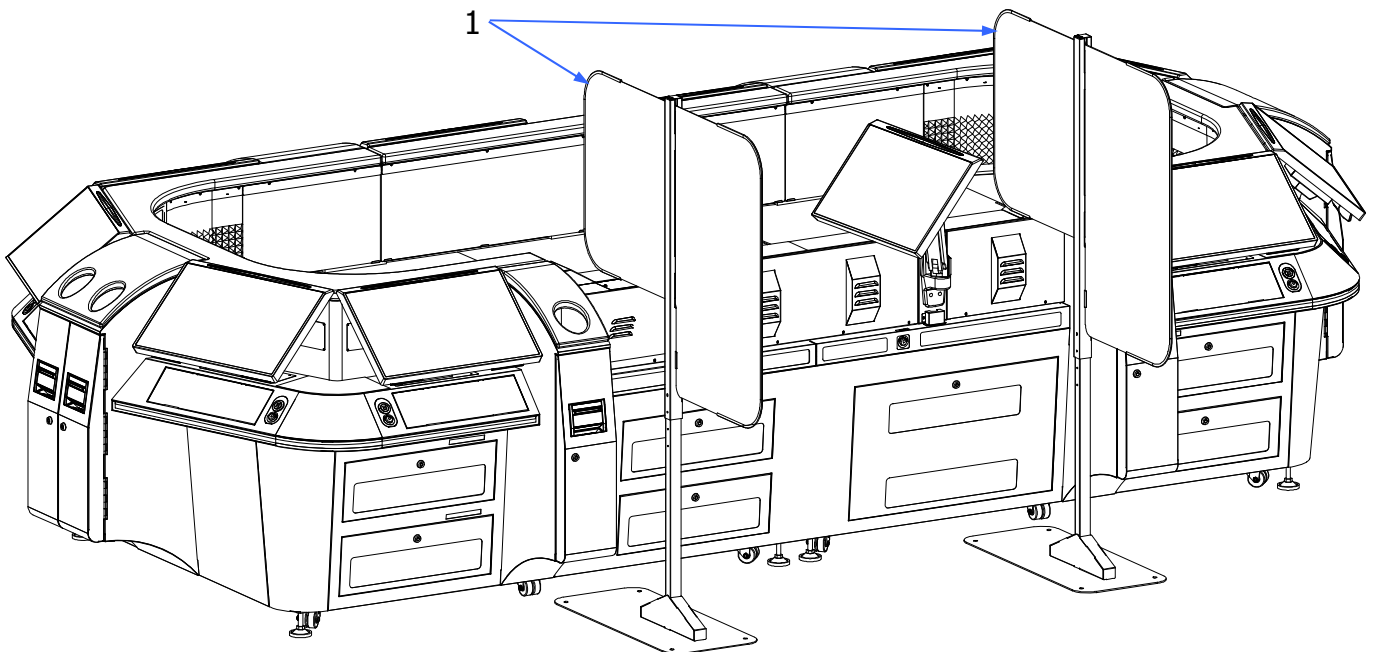

- 1. Dealer Partition Unit

Chapter 2

Unpacking and Inspection

2. 1: Unpacking and Inspection





Unpack the machine, and check for shipping damage. If anything is missing or damaged, immediately contact your local office or distributor.

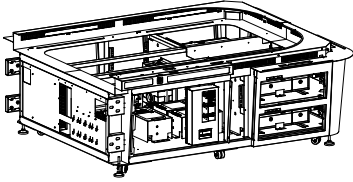
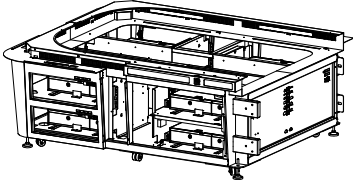
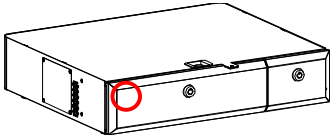

Supplied Part	QTY
Key (B2155)	1
Key (B1963)	1
Reset Key	1
Tower Light (Option)	(1)

 NOTE:

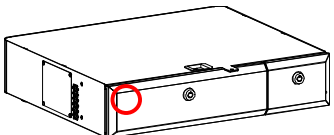
The content of the provided accessories may vary according to specifications.

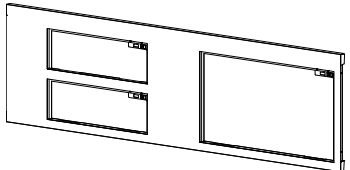
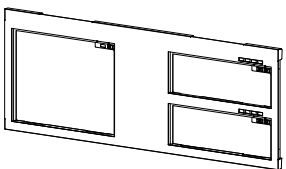

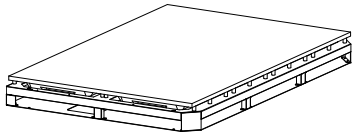
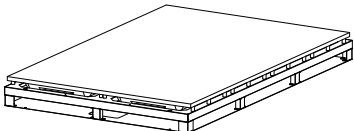
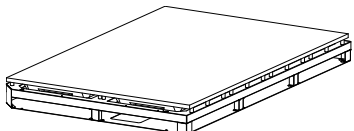
Packing List (for Center Unit)

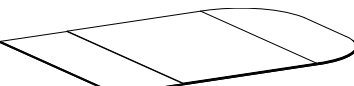
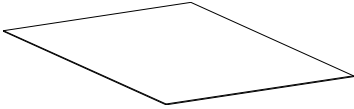
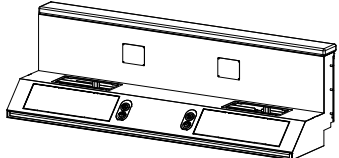
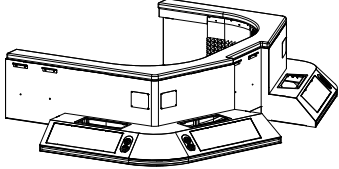
Parts Name		Qty	Appearance
1	Center Unit A	1	
2	Center Unit B	1	
3	Signage Controller Unit (※can be identified by the ID Sticker) Included inside the Center Unit	1	
4	Key Board Included with the Signage Controller Unit	1	
5	Main Controller Unit (for Dealer Terminal) (※can be identified by the ID Sticker) Included inside the Center Unit	1	
6	Station Controller Unit (for Player Terminal No.1~No.10) (※no sticker attached) Included inside the Center Unit	10	
7	Bottom LED Cover D Unit	1	
8	Bottom LED Cover C Unit	1	

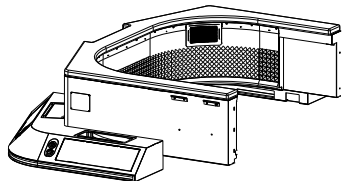
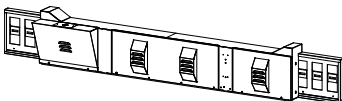
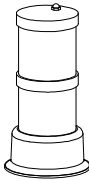
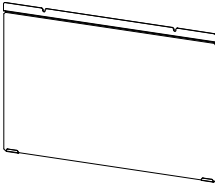
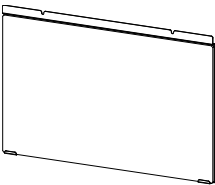
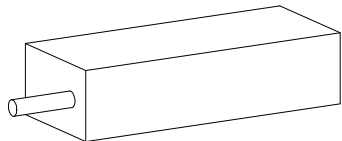
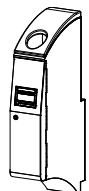
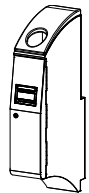
Parts Name		Qty	Appearance
9	Field LED Unit A (TPRC PANEL A) No.1 ※The actual appearance may differ from the illustration	1	
10	Field LED Unit B (TPRC PANEL B) No.2 and No.3 ※The actual appearance may differ from the illustration	2	
11	Field LED Unit C (TPRC PANEL C) No.4 ※The actual appearance may differ from the illustration	1	
12	AC Cable(for Field LED Unit)	4	
13	Field Glass	2	
14	URE SHEET A	1	
15	Mirror Wall Unit (Wall C)	1	
16	Side Wall Right Unit (Wall R)	1	

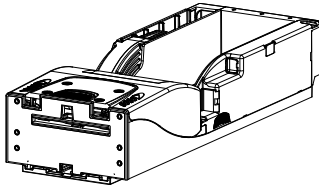
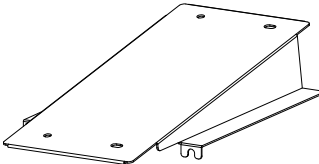
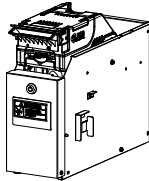
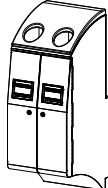
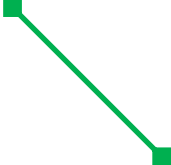
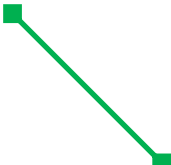
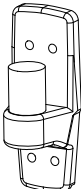
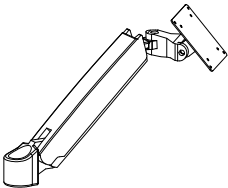
Parts Name		Qty	Appearance
17	Side Wall Left Unit (Wall L)	1	
18	Wall LED Unit	1	
19	Tower Light(OPTION)	1	
20	Mirror R BRKT	1	
21	Mirror L BRKT	1	
22	AC/DC Adapter(Option) (for USB Socket)	5	
23	Ticket Printer and Validator Unit (BV Case A) for the Player Terminals No.1(Left side)	1	
24	Ticket Printer and Validator Unit (BV Case C) for the Player Terminals No.10(Right side)	1	

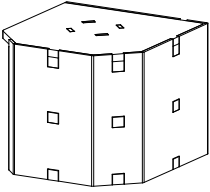
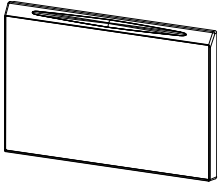
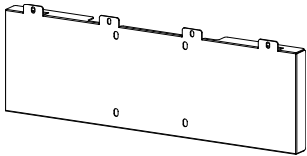
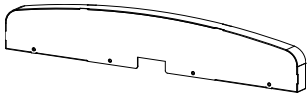
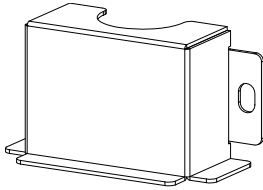
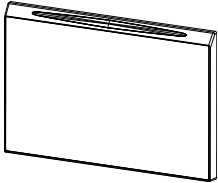
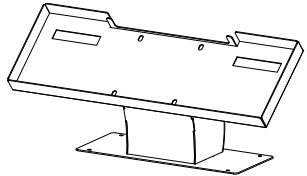
Parts Name		Qty	Appearance
25	Ticket Printer Unit	10	
26	Printer BRKT	10	
27	Validator Unit and Accessory Cable	10	
28	Ticket Printer and Validator Unit (BV Case B) for the Player Terminals Nos.2 – 3 (or Nos. 4 - 5, Nos. 6 - 7, Nos. 8 - 9)	4	
29	Earth Cable(GST-300-R2M4)	1	
30	GD-200 Harness	2	
31	Monitor Mount Base	1	
32	Monitor Mount Arm ※ERGOTRON Accessories for fixing included. (Cap, Sleeve, M6Washer, M6x45, 4mm Tool and Nylon Cable Tie)	1	

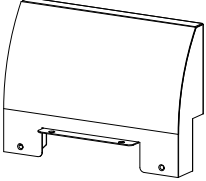
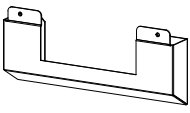
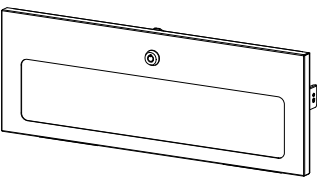
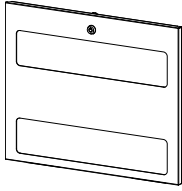
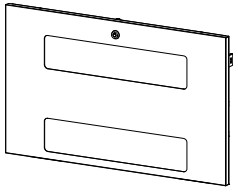

Parts Name		Qty	Appearance
33	Arm Stopper(Optional) ※Accessory part of No.32, can be used instead of the Cap.	1	
34	Monitor(for Dealer Terminal)	1	
35	Monitor Mount Arm Base(DL LCD BRKT)	1	
36	Monitor Connector Cover(DL LCD Cover)	1	
37	Cable Cover(DL Harness BRKT)	1	
38	Monitor(for Player Terminal)	10	
39	Monitor Stand(LCD BRKT)	10	
40	<ul style="list-style-type: none"> ·TPRC LCD ST Harness ·G USB(1.5m) Harness ·DP Cable(2.0m KS10007-20E) 	10 for each	

Parts Name		Qty	Appearance
41	Monitor Stand Cover A(LCD Cover A)	10	
42	Monitor Stand Cover B(LCD Cover B)	10	
43	Front Door(for Signage, Main, Station)	12	
44	Controller Door(Main DR A)	1	
45	Power Door(Main DR B)	1	

Packing List (Option Parts)

i NOTE: Option-2

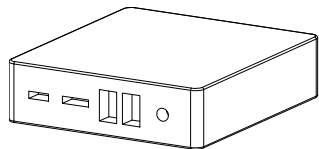
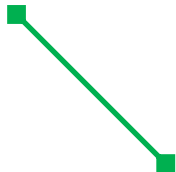
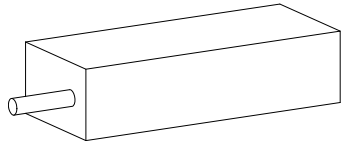
In case it was chosen the Option to use the Tipping System Unit (Option).

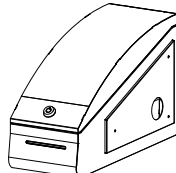
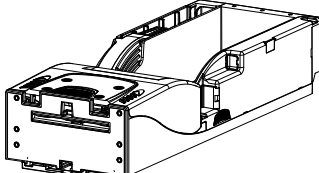
Parts Name		Qty	Appearance
46	<ul style="list-style-type: none"> · SMALL PC LIVAZ-4/32 (N3350) · 12V AC/DC Adapter(for SMALL PC) · Ring Fix Tape ※It may be fixed to the LED Controller Unit. 	1	
47	<ul style="list-style-type: none"> Cat5e LAN CABLE 0.5m ※It may be fixed to the LED Controller Unit. 	1	
48	<ul style="list-style-type: none"> 24V AC/DC Adapter(for Printer) ※Included under the Part Name [PRWC PS AD HARNESS] 	1	
49	AC Cable(for Printer)		
50	Tipping System Unit(Option)	1	
	Ticket Printer Unit	1	

Fastener List

Fasteners		Qty	Appearance
Ab	TRUSS M4x8 BLK	4	

I	PAN M5x10 3P	3	
---	--------------	---	---

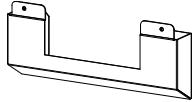
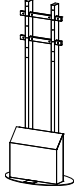
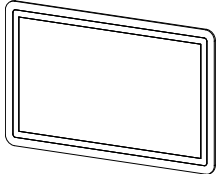
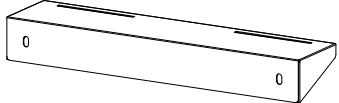
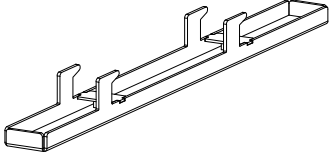
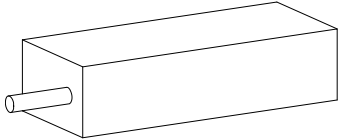

i NOTE: Option-3

In case it was chosen the Option to add an History Display Unit.

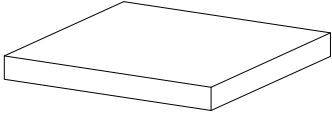
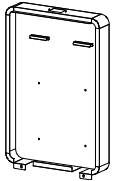
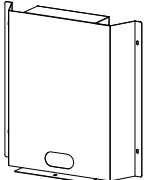
Parts Name		Qty	Appearance
51	Monitor Stand Cover B(LCD Cover B)	10	
52	Display Stand Unit	1	
53	History Display Unit	1	
54	Top Cover Support BRKT	1	
55	History Display BRKT ※If it is fixed to the Display Stand Unit, detach it.	2	
56	Switching Power Adapter	1	

Parts Name		Qty	Appearance
57	Ring Fix Tape	8	
58	History Display Top Cover Unit	1	
59	History Display Bottom Cover(Cover A)	1	

Fastener List

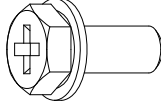
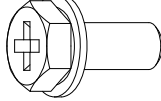
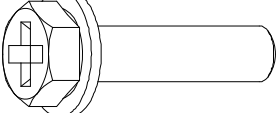

Fasteners		Qty	Appearance
Ab	TRUSS M4x8 BLK	10	
F	PAN M4X8 3P	1	
R	FLANGE NUT M4	2	
Wb	HEX UPSET M6 x 14 3P BLK	2	
X	HEX UPSET M6 x 15 3P	6	
Y	HEX UPSET M8 x 35 3P	4	

i NOTE: Option-4

In case it was chosen the Option to output images to external Monitors.

Please pay attention because the parts to use varies for each different video output type.

[Betting status] for Surveillance Monitor

Parts Name		Qty	Appearance
	External Monitor for [Betting status] Use an external Monitor with DVI Input port and no audio output .	1	Input Port  DVI
60	MiniDP-DVI_ACTIVE KS30015-00E Item code : 6P1046100 for [Betting status]	1	MiniDP-DVI Adapter 
	DVI Cable for [Betting status] Choose the cable length according to the installation environment.	1	

[GAME Field and WALL Display] for Audience Live viewing Monitor

Parts Name		Qty	Appearance
	External Monitor for [GAME Field and WALL Display] Use an external Monitor with DP or HDMI Input port and no audio output .	1	Input Port  DP or HDMI
	MiniDP-DP(or MiniDP-HDMI) Cable for [GAME Field and WALL Display] Choose the cable length according to the Input Port of the Monitor and the installation environment.	1	

i NOTE: Option-5

As Field Options, it is possible to choose either Field Bumps or Field Fabric.

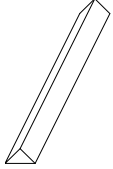
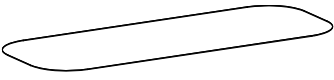
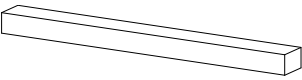
Parts Name		Qty	Appearance
61	Field Bump	4	
62	Field Fabric	1	
63	Fabric Stopper	12	

i NOTE: Option-6, 7

In case it was chosen the Option to use the Operation Stop Key Unit or Terminal Operation Button.

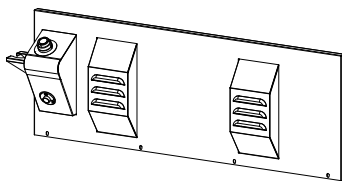
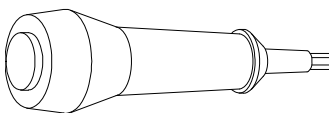
Parts Name		Qty	Appearance
64	Wall MID Cover ※It may be fixed to the Wall LED Unit. ·Operation Stop Key Unit and Key	1	
65	Terminal Operation Button	1	

i NOTE: Option-8

In case it was chosen the Option of Field Glass with Steps.

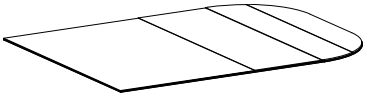
Parts Name		Qty	Appearance
66	Option: Field Glass	2	

i NOTE: Option-9

In case it was chosen the Option to add the Dice Tilt Rubber.



Parts Name		Qty	Appearance
67	Dice Tilt Rubber	4	

NOTE: Option-10

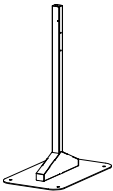
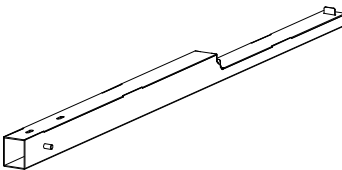
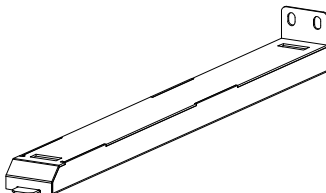
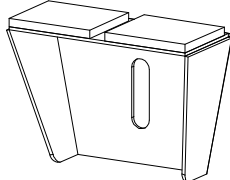
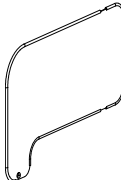
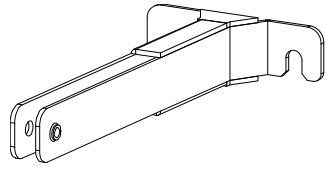
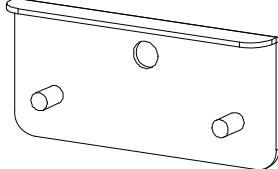
In case it was chosen the Option to use the Player Partition Units.

Parts Name		Qty	Appearance
68	Player Partition Base	1	
69	Player Partition BRKT A	1	
70	Player Partition BRKT B	1	
71	Player Partition Fix BRKT	1	
72	Player Partition	1	
73	Player Partition Holder A	1	
74	Player Partition Holder B	1	

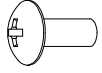
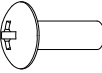
Fastener List

Fasteners		Qty	Appearance
Bg	TRUSS M4x10 GLD	6	
C	TRUSS M4x12	1	
Rb	FLANGE NUT M4 BLK	2	
AZ	WING NUT M6	1	

i NOTE: Option-11



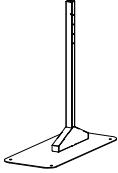
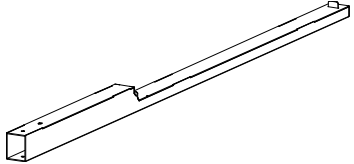
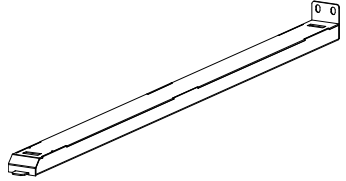
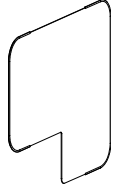







In case it was chosen the Option to use the Dealer Partition Units.

Parts Name		Qty	Appearance
75	Dealer Partition Base	2	
76	Dealer Partition BRKT A	2	
77	Dealer Partition BRKT B	2	
78	Dealer Partition	2	







Fastener List

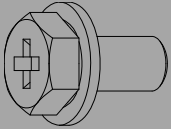
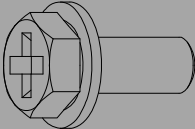
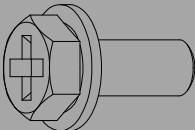
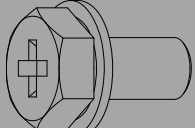
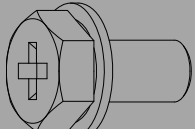

Fasteners		Qty	Appearance
Bg	TRUSS M4x10 GLD	12	

Fastener List

Fasteners		Appearance
Ab	TRUSS M4x8 BLK	
Bb	TRUSS M4x10 BLK	
Bg	TRUSS M4x10 GLD	
C	TRUSS M4x12	
Cb	TRUSS M4x12 BLK	
Db	TRUSS M5x10 BLK	
E	PAN M4X6 3P	
F	PAN M4X8 3P	
Fb	PAN M4X8 3P BLK	
G	PAN M4x10 3P	
Gb	PAN M4x10 3P BLK	

Fasteners		Appearance
I	PAN M5x10 3P	
Ib	PAN M5x10 3P BLK	
J	PAN M5x12 3P	
Jb	PAN M5x12 3P BLK	
K	HEX UPSET M6 x 10 3P	
Kb	HEX UPSET M6 x 10 3P BLK	
L	HEX UPSET M6 x 12 3P	
Lb	HEX UPSET M6 x 12 3P BLK	
M	HEX UPSET M6 x 16 3P	
Mb	HEX UPSET M6 x 16 3P BLK	
N	HEX UPSET M8 x 16 3P	

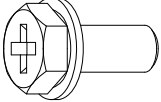
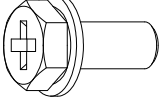
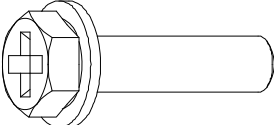
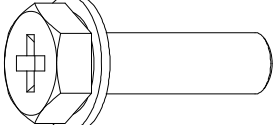
Fasteners		Appearance
Nb	HEX UPSET M8 x 16 3P BLK	
O	HEX UPSET M8 x 20 3P	
Ob	HEX UPSET M8 x 20 3P BLK	
P	HEX UPSET M10 x 20 3P	
Q	HEX UPSET M10 x 20 3P BLK	
R	FLANGE NUT M4	
Rb	FLANGE NUT M4 BLK	
S	FLANGE NUT M5	
T	FLANGE NUT M6	
U	PAN M3X6 3P	
Vb	HEXALOBULAR INTERNAL M4x8 BLK (Torx)	

Fasteners		Appearance
Wb	HEX UPSET M6 x 14 3P BLK	
X	HEX UPSET M6 x 15 3P	
Y	HEX UPSET M8 x 35 3P	
Z	HEX UPSET M10 x 35 3P	
AZ	WING NUT M6	

Chapter 3

Installation

3. 1: Cabinet Dimensions

The Whole Machine dimensions are depicted below.

Secure enough space so that the doors can be easily opened for POWER-ON/OFF, maintenance, and so on.

- **Outer Dimension - Unit: mm** (excluding all parts sticking out)

The History Display Unit and the TOWER LIGHT are optional.

155(Height of 2 tiers tower light) / 200(Height of 3 tiers tower light)

Provide the minimum space from surrounding walls/machines required by each machine.

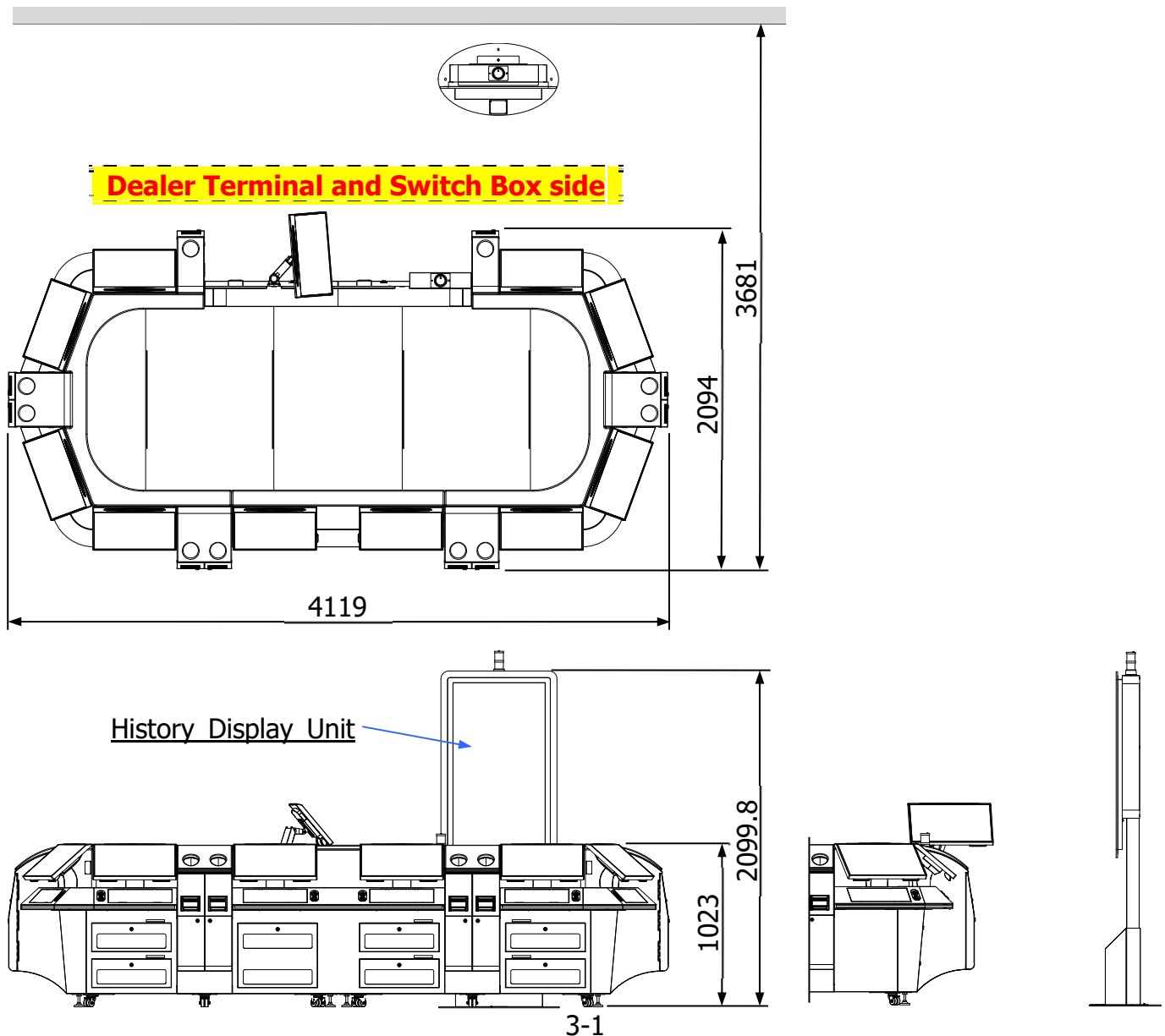

3. 2: Installing the Machine

⚠ WARNING!

- Installation must be performed by qualified service personnel.
- To install this machine, at least 4 people are necessary.
- Before starting installation procedures, refer to "**Safety Instructions**".
- Interblock d.o.o. cannot be held liable for damages or injuries caused by improper installation.

i NOTE:

For this machine it is possible to choose the following optional layouts:

Option-1 : It is possible to choose the position of the Tower Light, either on the top of the Wall LED Unit, or on the History Display Unit (Optional) if selected as **Option-3**. (Refer to 3.2.8)

Option-2 : It is possible to expand the Tipping System Unit (Option). (Refer to 3.2.10)
(※ For more details refer to [TIPPING SYSTEM OPERATION MANUAL for ARUZE Service])

Option-3 : It is possible to display a record of the last game results, by installing in addition the History Display Unit (optional). (Refer to 3.2.16)

Option-4 : It is possible to output a review of the [Betting Status] to an external Monitor for Surveillance use, and a streaming of the [GAME Field and WALL Display] to another external Monitor for Audience Live viewing. (Refer to 3.2.17)

Option-5 : As Field Options, it is possible to choose either Field Bumps or Field Fabric. (Refer to 3.2.20)

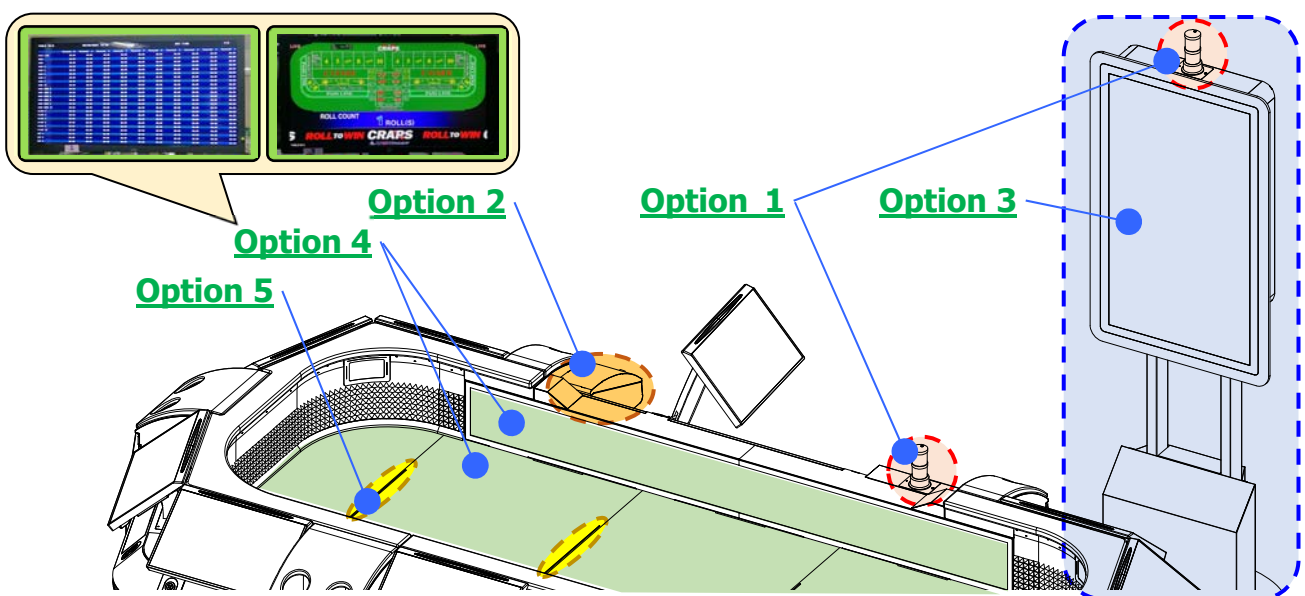

Option-6 : It is possible to install the Operation Stop Key Unit (Option) as Dealer Support function. It is possible to operate on the Dealer Terminal only when the Key is turned toward "ON". (Refer to 3.2.5)

Option-7 : It is possible to install the Terminal Operation Button (Option) as Dealer Support function. It is possible to input the "DICE RESULT" only when the Button is pressed. (Refer to 3.2.5)

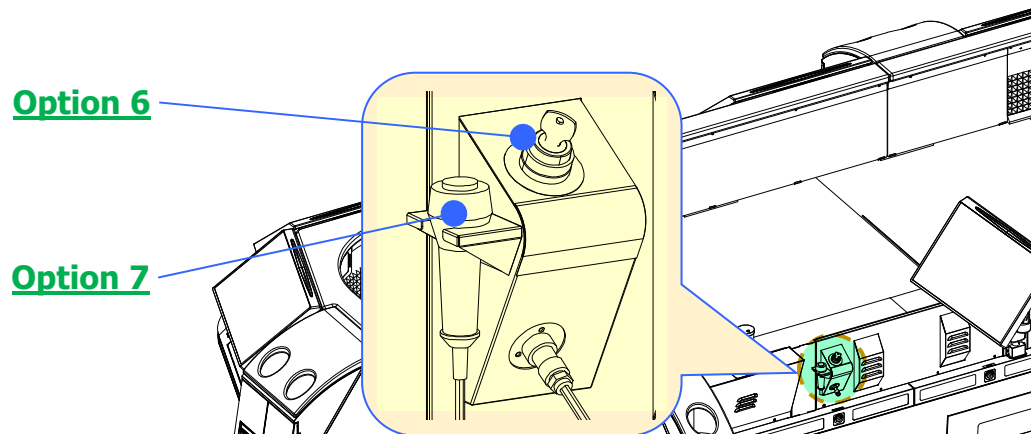

Option-8 : As Field Options, it is possible to choose a Field Glass with steps, instead of the Field Bump or Field Fabric of **Option-5**. (Refer to 3.2.7)

Option-9 : By adding the Dice Tilt Rubber, it is possible to reduce the number of slanted Dice. (Refer to 3.2.21)

Option-10: It is possible to partition the areas of adjacent players by setting up the Player Partition Unit. (Refer to 3.2.22)

Option-11: It is possible to partition the area of the Dealer by setting up the Player Partition Unit. (Refer to 3.2.23)

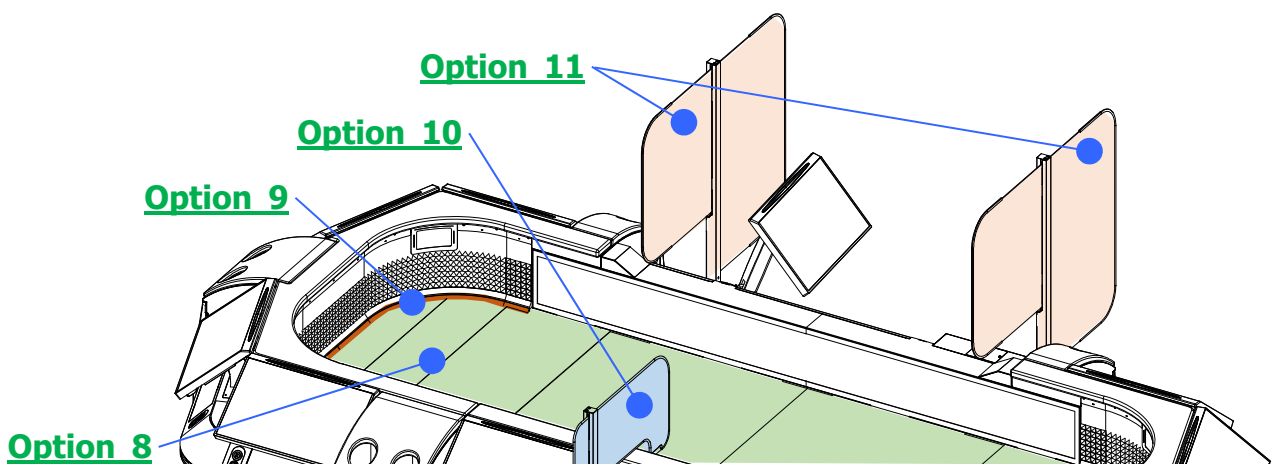

Preparation

- To preserve the horizontal level, install the machine on a solid surface that will not suffer the influence of vibration.
- Check the procedures in advance and arrange a disposition that will allow enough space for the work.
- Mount the machine in an area equipped with power and communication cables.
- This machine needs Power Cables for the Center Unit (x3), and also power sockets (x12) for the internal equipment and the History Display Unit (optional), as well as power sockets (x2) for the Tipping System Unit (Option).

i NOTE:

The Power Switches of the Feld LED, Wall LED, History Display Unit (Option) and Tipping System (Option) are fixed to ON, so connecting the AC Cables to an electrified Power Source will boot them ON. (The Controller Unit does not boot up, so no images will be displayed on the Field LED, Wall LED and History Display (optional)). Remember that the Power Switch of the Center Unit is not connected at the same time.

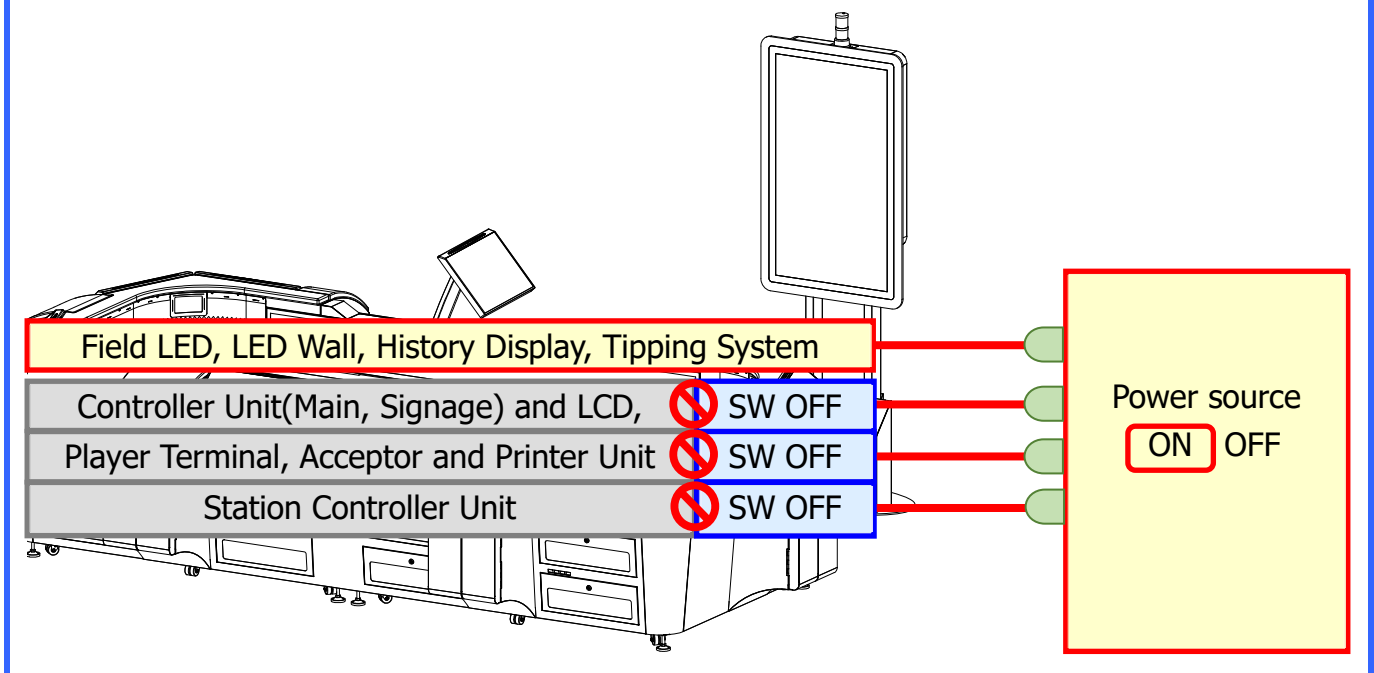

Before installing the machine, prepare the following tools:

- Ratchet wrench with sockets of S=7, 8, 10, 12, 13, and 19mm Otherwise, open-end wrenches (+19mm) with the same sizes
- Phillips screwdriver (#2)
- Torx screwdriver(T15)
- Waste cloth

3. 2. 1: Installing the Center Unit

1. Prepare the following Parts.

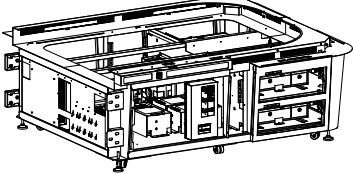
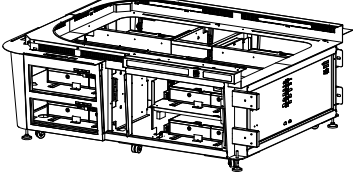
Parts Name	Qty	Appearance
Center Unit A	1	
Center Unit B	1	

2. Remove the protective tape from the junction side of the Center Unit B. Check the internal and external sides of the connectors and make sure that there is no damage to the connectors and no Connector Pin is missing.

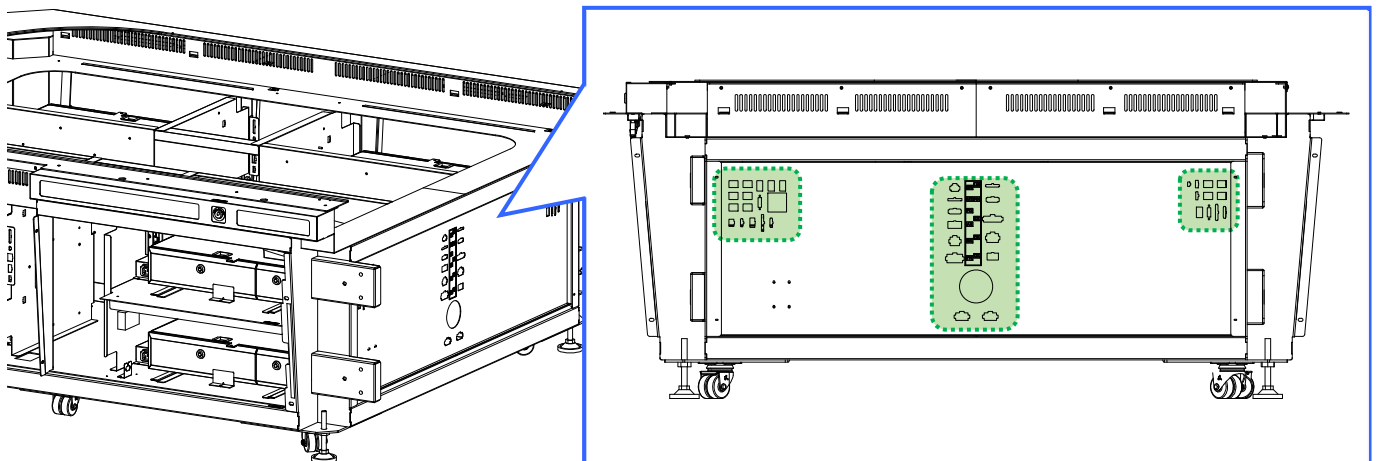

- According to the chosen layout, place the Center Unit at your desired position on a flat floor, where cables for electricity and communication have already been installed.

i NOTE:

- When planning the layout of the Center Unit, remember that its Power Cable is connected to the Terminal Block through a hole on the bottom of the Center Unit.

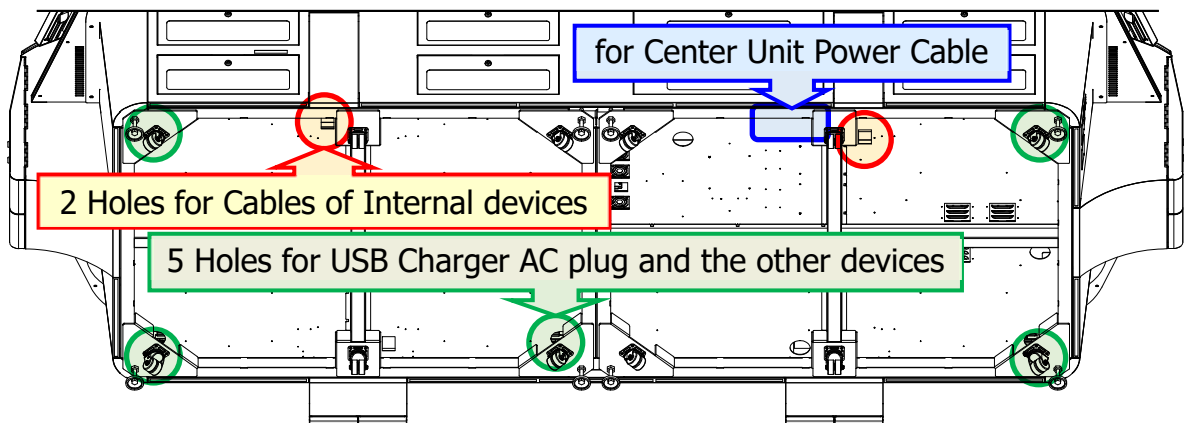
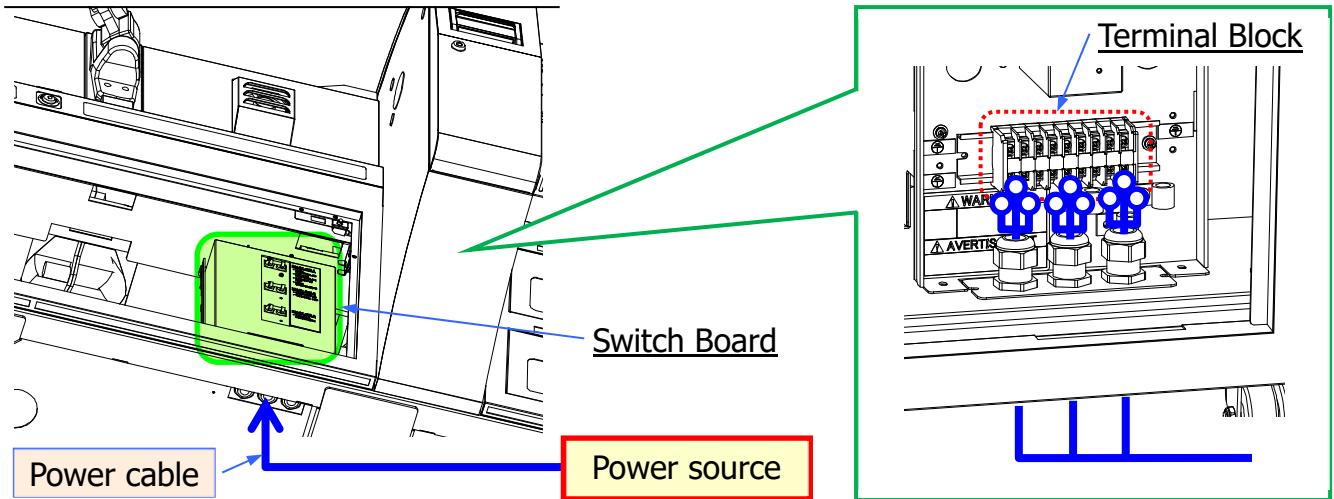

Location of Power Cable Holes of the Center Unit

- The History Display is connected to the Center Unit through an attached cable (approximately 3m). Please consider this when planning the layout of the machine.

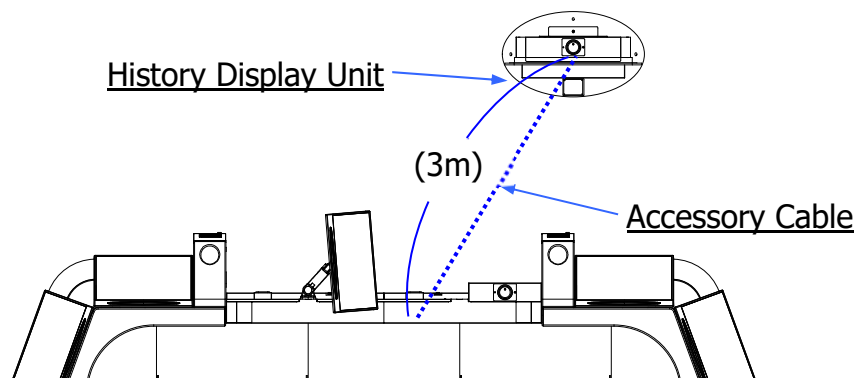

- Place the Center Unit A and the Center Unit B in a parallel position, so that they face each other junction side, and then, while paying attention to the connectors on each junction side, move the units straight toward each other to join them.

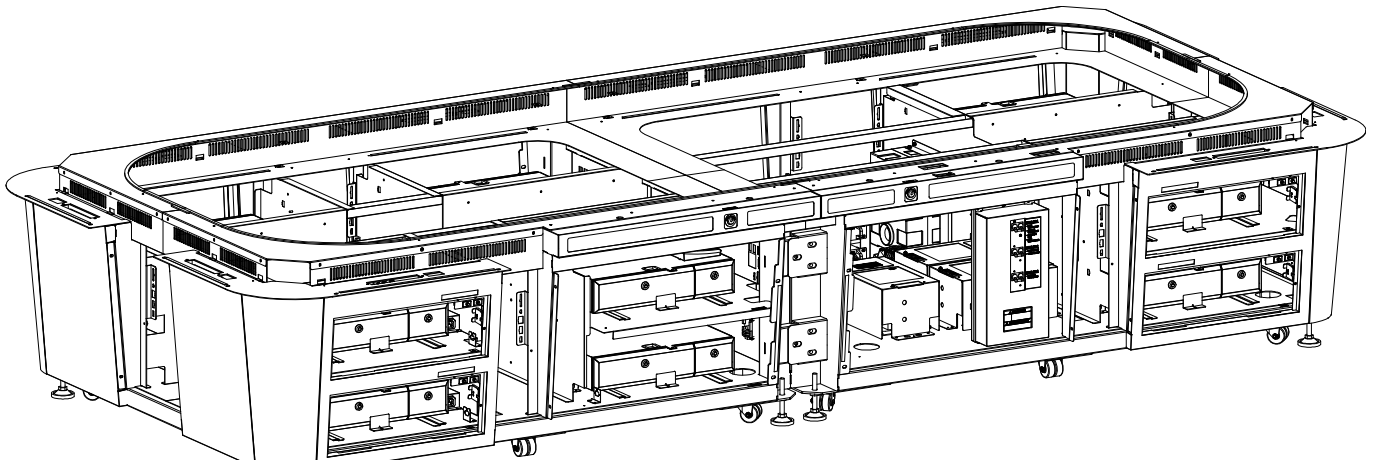
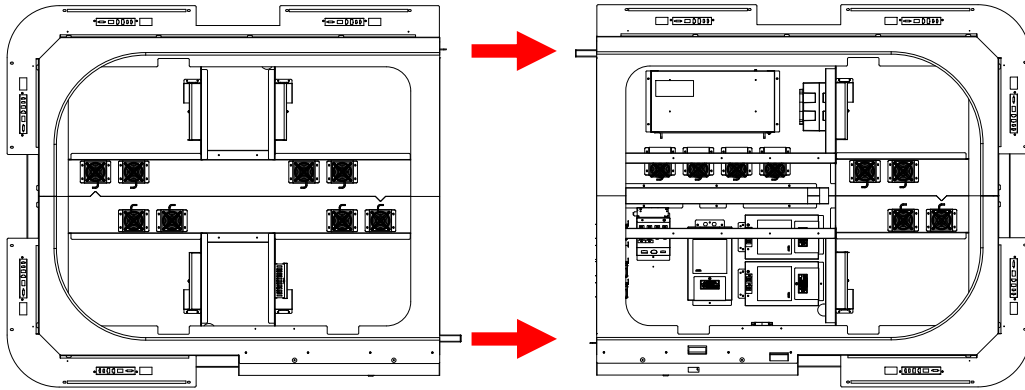

- Affix the 6 bolts from both sides of the Center Unit.

Fasteners		Qty	Appearance
Z	HEX UPSET M10 x 35 3P	12	

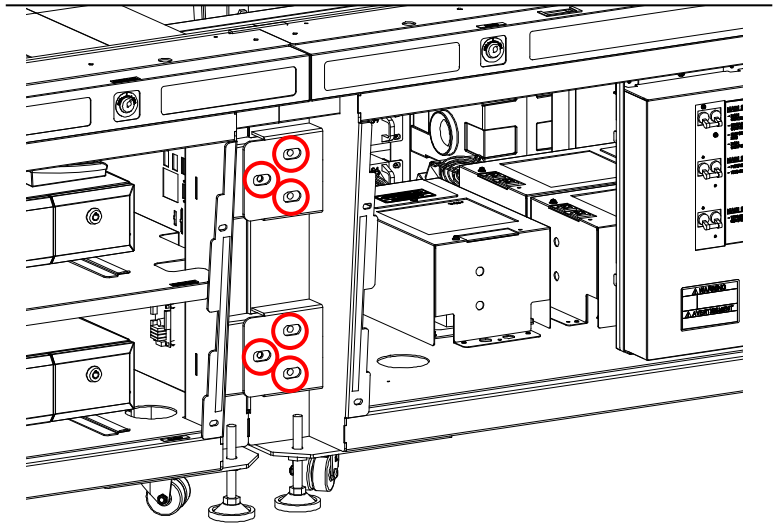
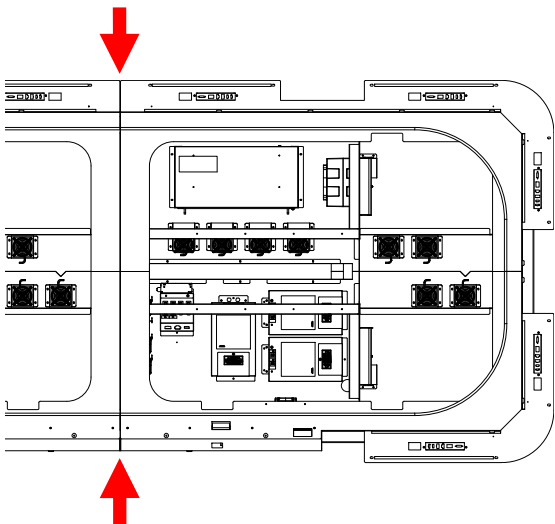

- Secure the Center Unit to the floor by lowering the adjuster situated at the bottom of the machine.

⚠ WARNING

Any movement of the Center Unit during the installation or during the game operations, is extremely dangerous. Secure the Center Unit so that it is firmly fixed on the ground.



- Check the cables tied with tape, which are in the inner part of the Center Unit A, and untie them.

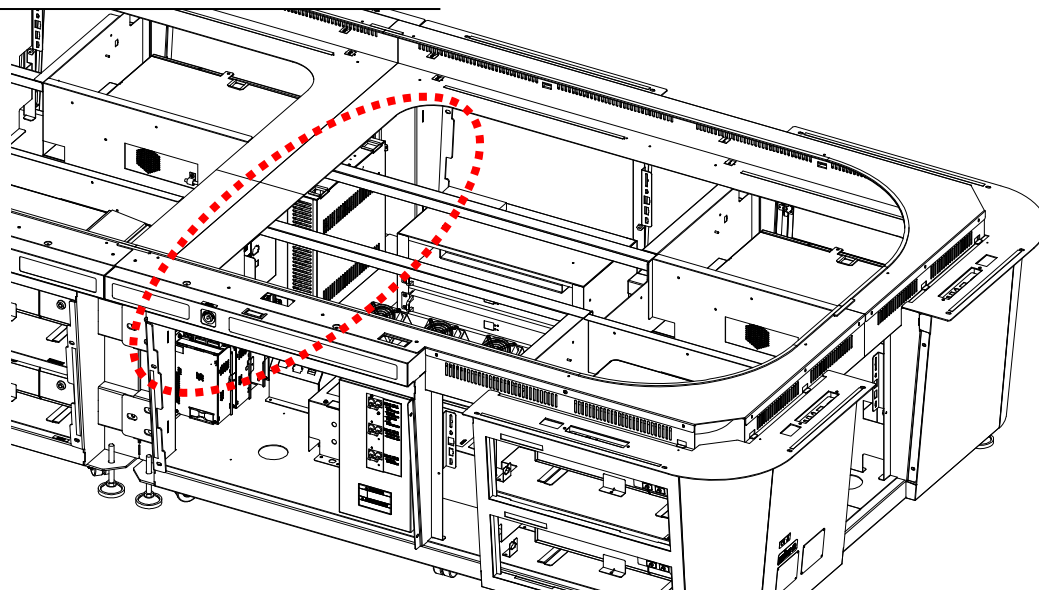

- Refer to the chart below and connect the connectors of the Center Unit B to the connectors of the Center Unit A.

i NOTE:

As the installation proceeds, the access to the connectors becomes more difficult, therefore make sure to connect firmly all the way each connector. If there is any damage to the connectors, or any connector pin is missing, please fix them at this STEP.

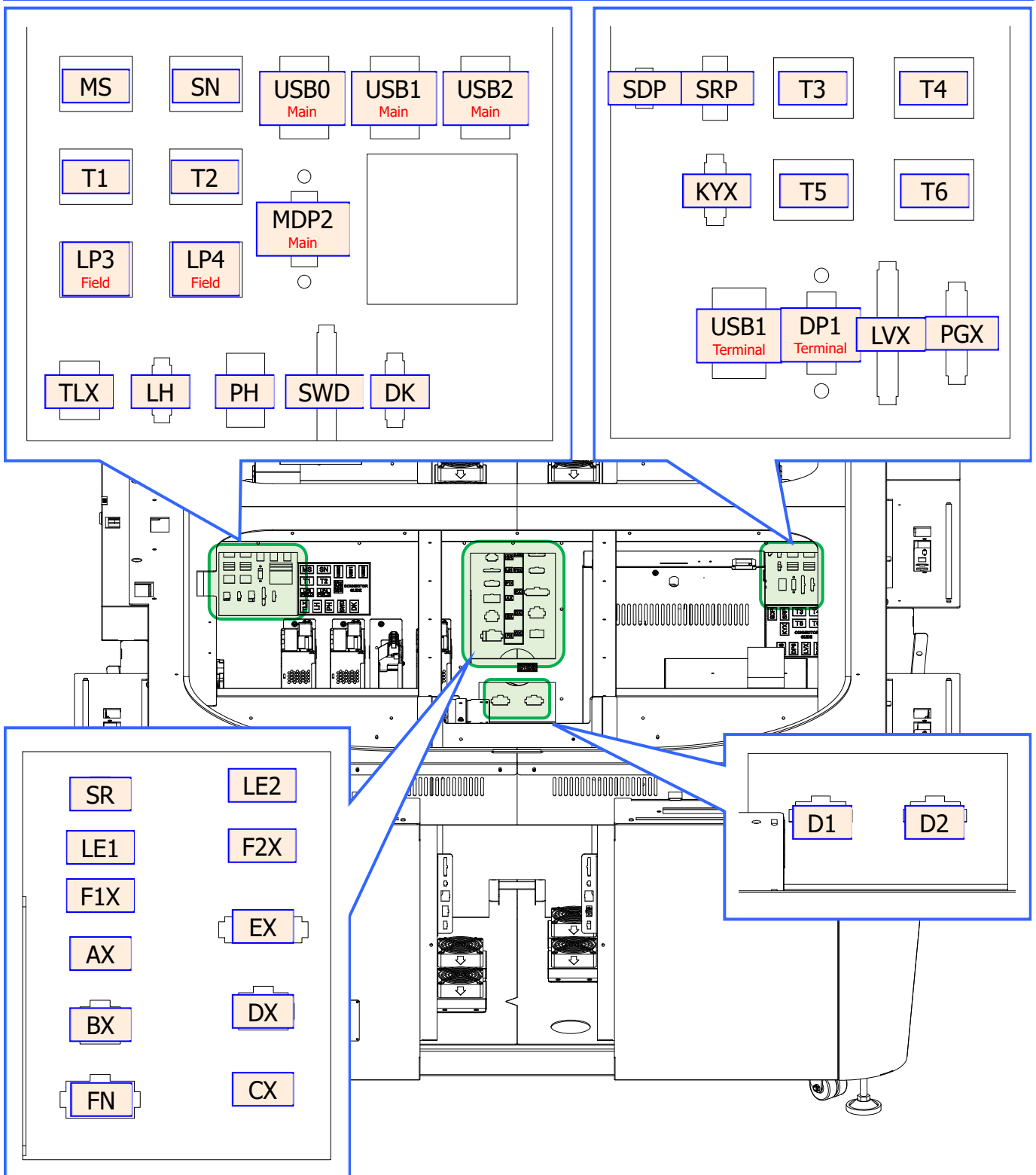

3. 2. 2: Assembling the Bottom LED Cover Units

i NOTE:

- To install this machine, at least 2 people are necessary.
- Before starting the procedure, remove the Hold BRKTs that are affixed by screws, and draw out the 12 Controller Units that are inside the Center Unit.

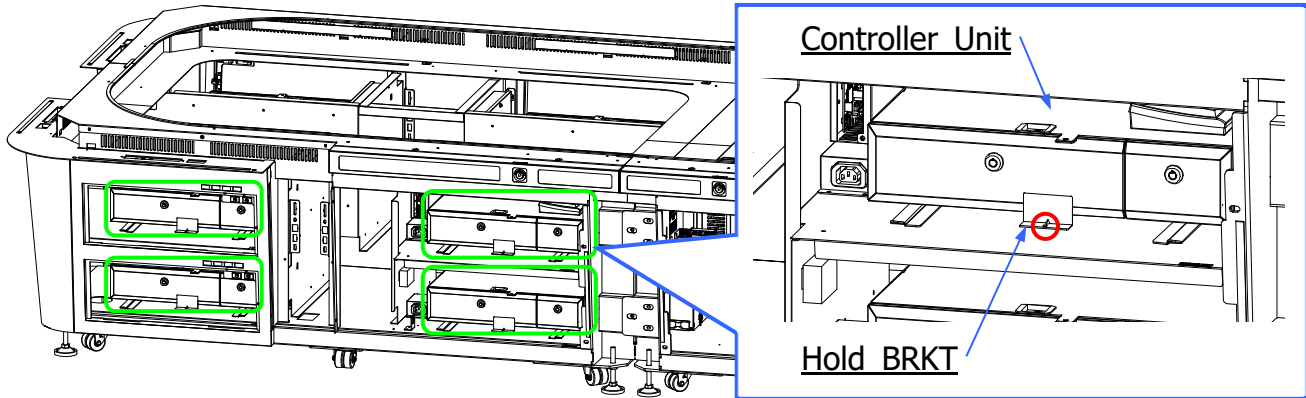

1. Untie the FX, DPF, MX, OPM, MD1, OP1, BL (x2) connectors that are tied with tape on the side of the Switch Box of the Center Unit, and arrange them so that will not interfere with the next operations.

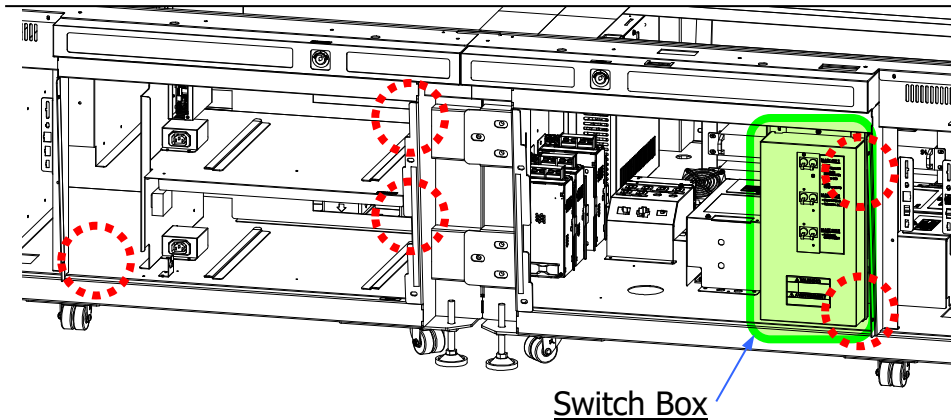

2. Prepare the following Parts.

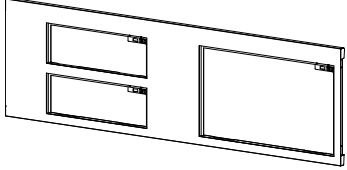
Parts Name	Qty	Appearance
Bottom LED Cover D Unit	1	

3. Locate the Mechanical Switches and Optical Sensors that are in the 3 positions of the inner side of the Bottom LED Cover D indicated below, then untie the BSX(x2) Connectors.

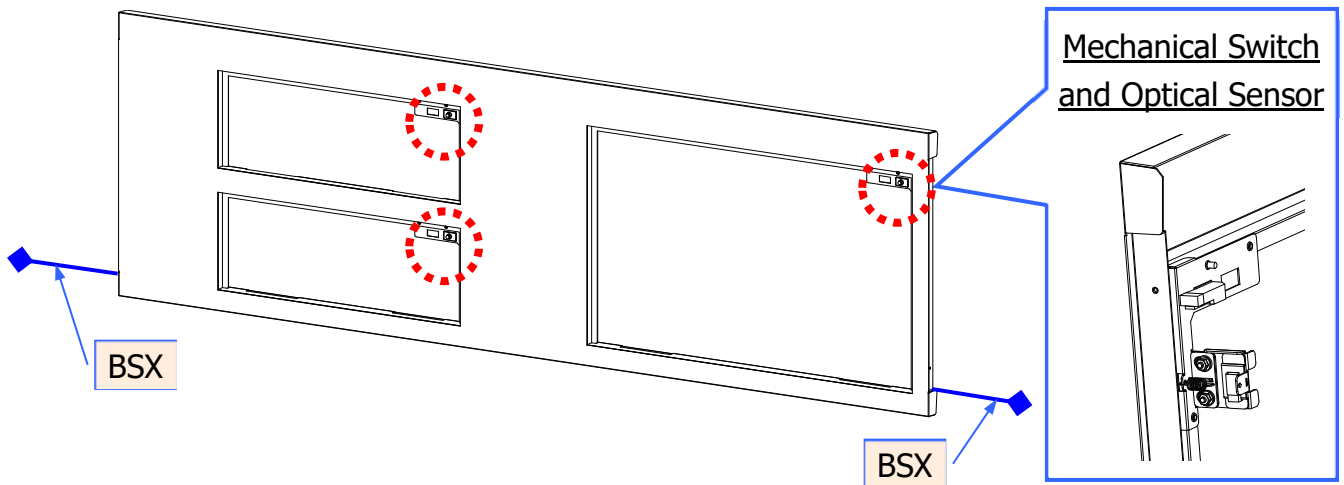

4. Install the Bottom LED Cover D Unit on the Center Unit, and affix it from the two lateral sides and from the rear side of the Bottom LED Cover D Unit, by using 4 screws and 4 nuts.

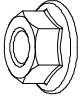
Fasteners		Qty	Appearance
Db	TRUSS M5x10 BLK	4	
T	FLANGE NUT M6	4	

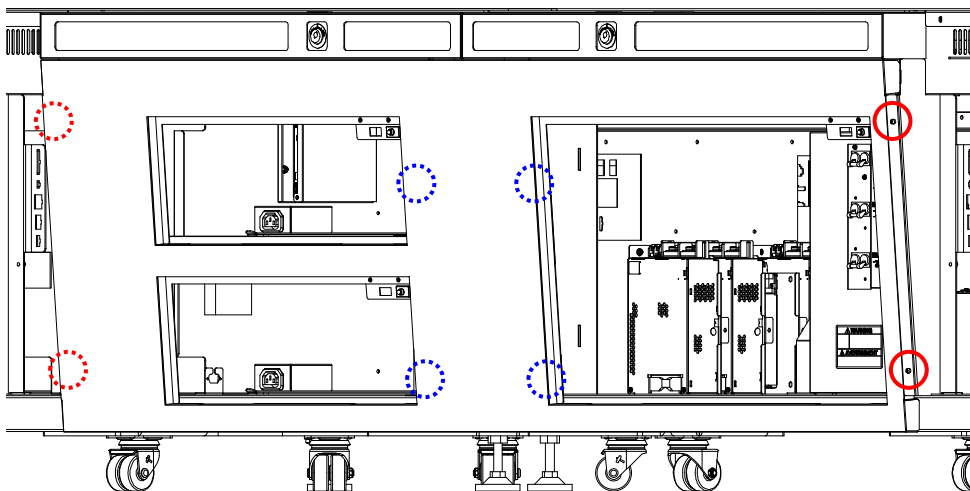

5. Connect the Mechanical Switches and the Optical Sensors that are in the 3 positions of the inner side of the Bottom LED Cover D indicated below, checked at STEP 3, to the FX, DPF, MX, OPM, MD1 and OP1 Connectors of the Center Unit, that were prepared at STEP 1.

i NOTE:

The length of the cables of the connectors is short. Pay attention not to damage them when connecting.

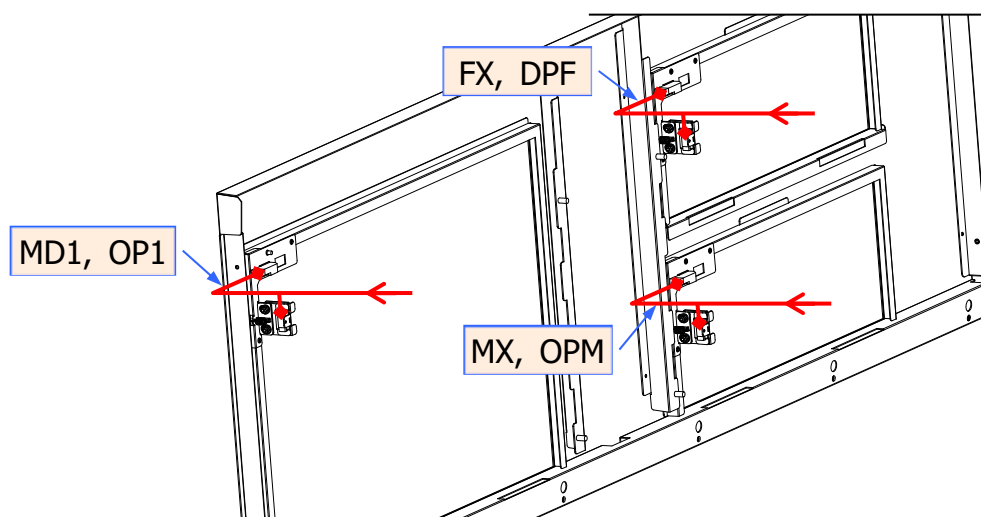

6. Connect the BSX Connectors of the Bottom LED Cover D Unit that were checked at STEP 3 to the BL(x2) Connectors if the Center Unit that were prepared at STEP 1.

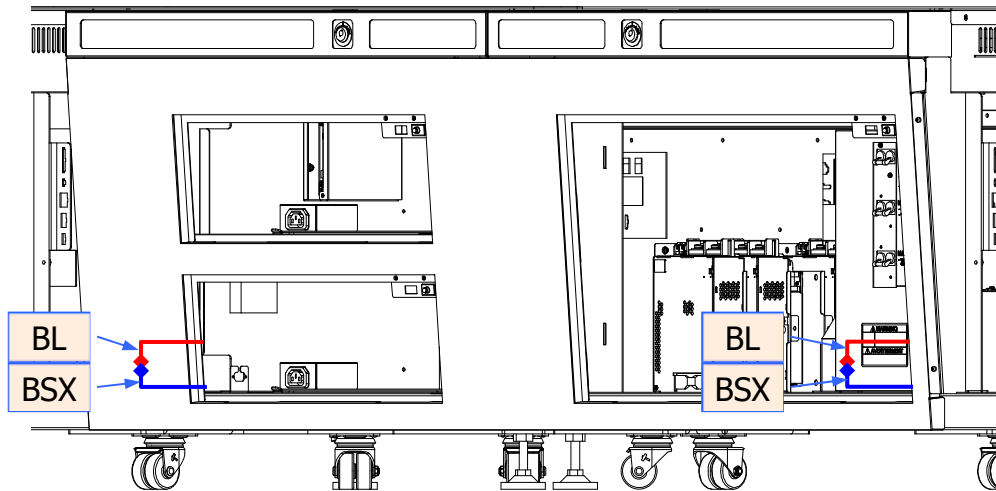

7. Untie the DR(x2), OP(x2), ISO (x2), MD2, OP2, BT1, BT2, BLX(x2) connectors that are arranged on the side of the LED Controller Unit of the Center Unit, and arrange them so that will not interfere with the next operations.

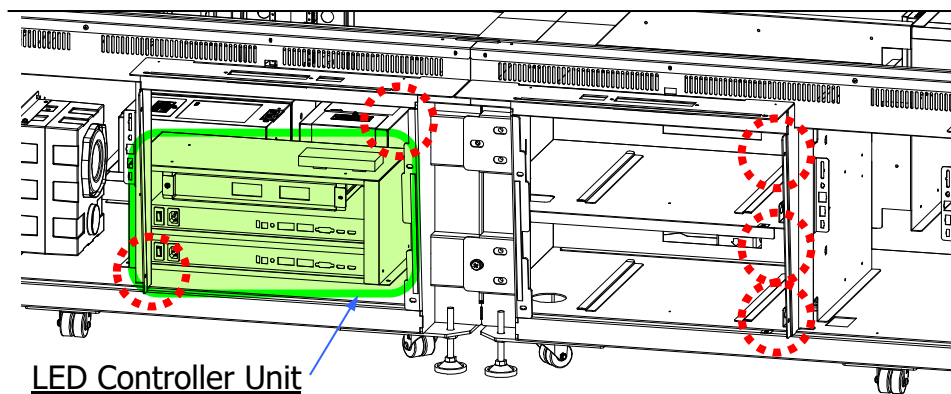



8. Prepare the following Parts.

Parts Name	Qty	Appearance
Bottom LED Cover C Unit	1	

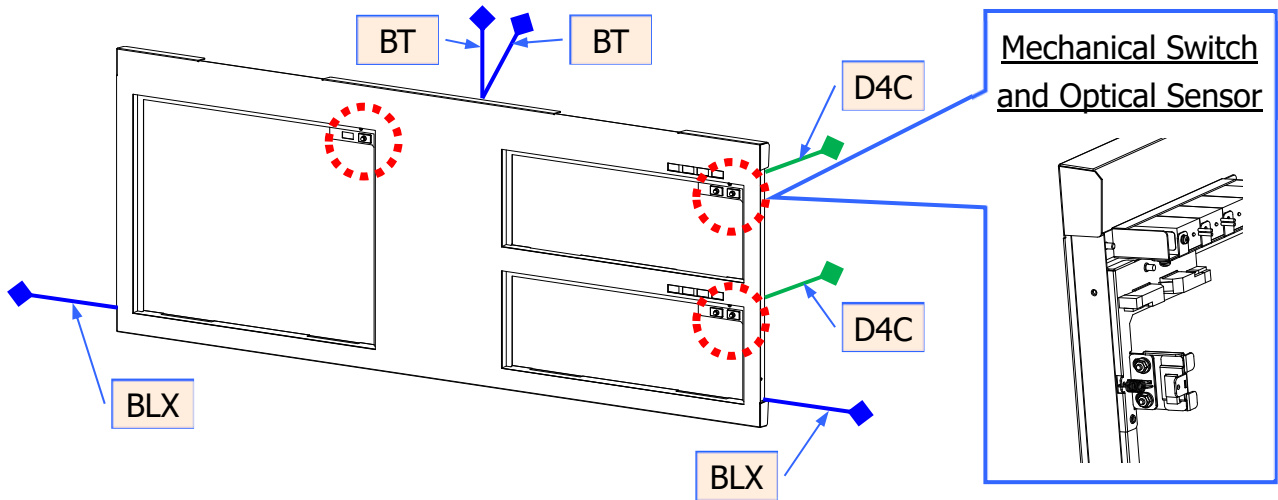
9. Locate the Mechanical Switches and Optical Sensors that are in the 3 positions of the inner side of the Bottom LED Cover D indicated below, then untie the BLX(x2) and BT(x2) Connectors, and if the Counter (Option) is included, also the D4C(x2) Connectors.



10. Install the Bottom LED Cover C Unit on the Center Unit, and affix it from the two lateral sides and from the rear side of the Bottom LED Cover C Unit, by using 4 screws and 4 nuts.

Fasteners		Qty	Appearance
Db	TRUSS M5x10 BLK	4	
T	FLANGE NUT M6	4	

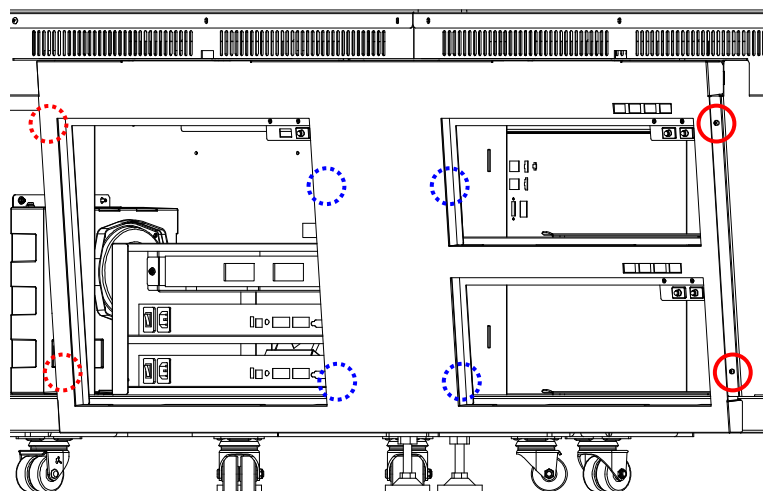

- Connect the Mechanical Switches and the Optical Sensors that are in the 3 positions of the inner side of the Bottom LED Cover C indicated below, checked at STEP 9, to the DR(x2), OP(x2), ISO(x2), MD2 and OP2 Connectors of the Center Unit, that were prepared at STEP 7.

i NOTE:

The length of the cables of the connectors is short. Pay attention not to damage them when connecting.

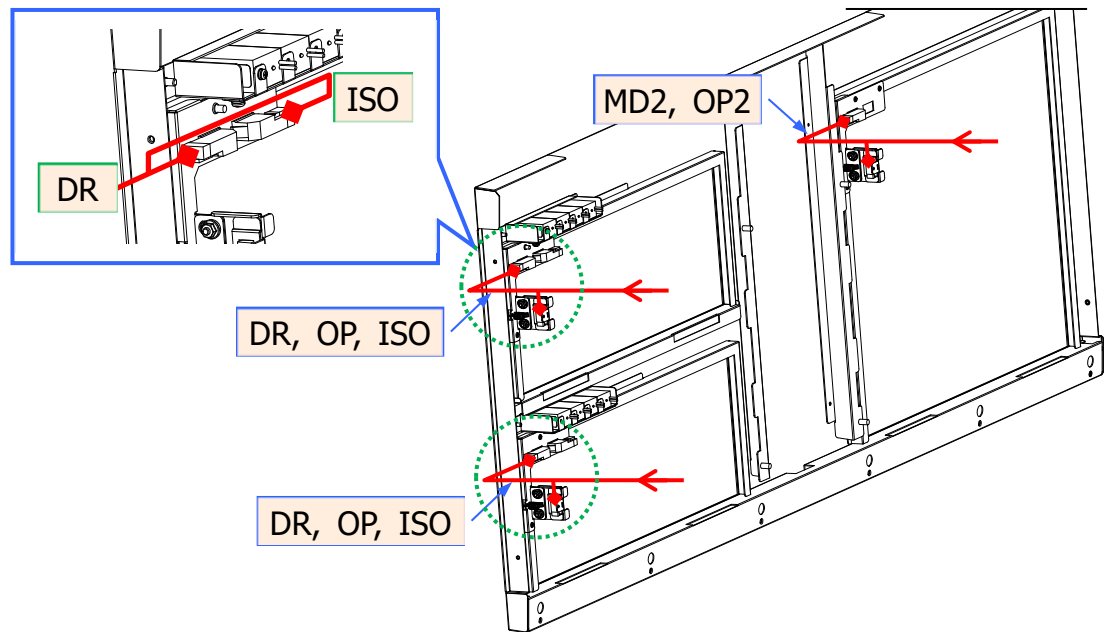

- Connect the BLX(x2) and BT(x2) Connectors of the Bottom LED Cover C Unit that were checked at STEP 9 to the BLX(x2), BT1, BT2 Connectors of the Center Unit that were prepared at STEP 7.

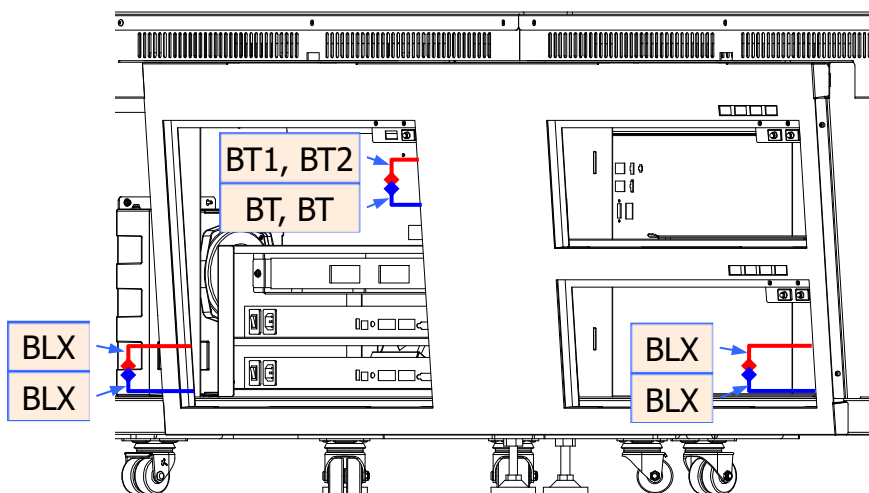

13. Remove the screw of the SUB IO Case that is inside the inner shelf of the Center Unit, then pull out the USB1 Connector and return the SUB IO Cover to its original place.

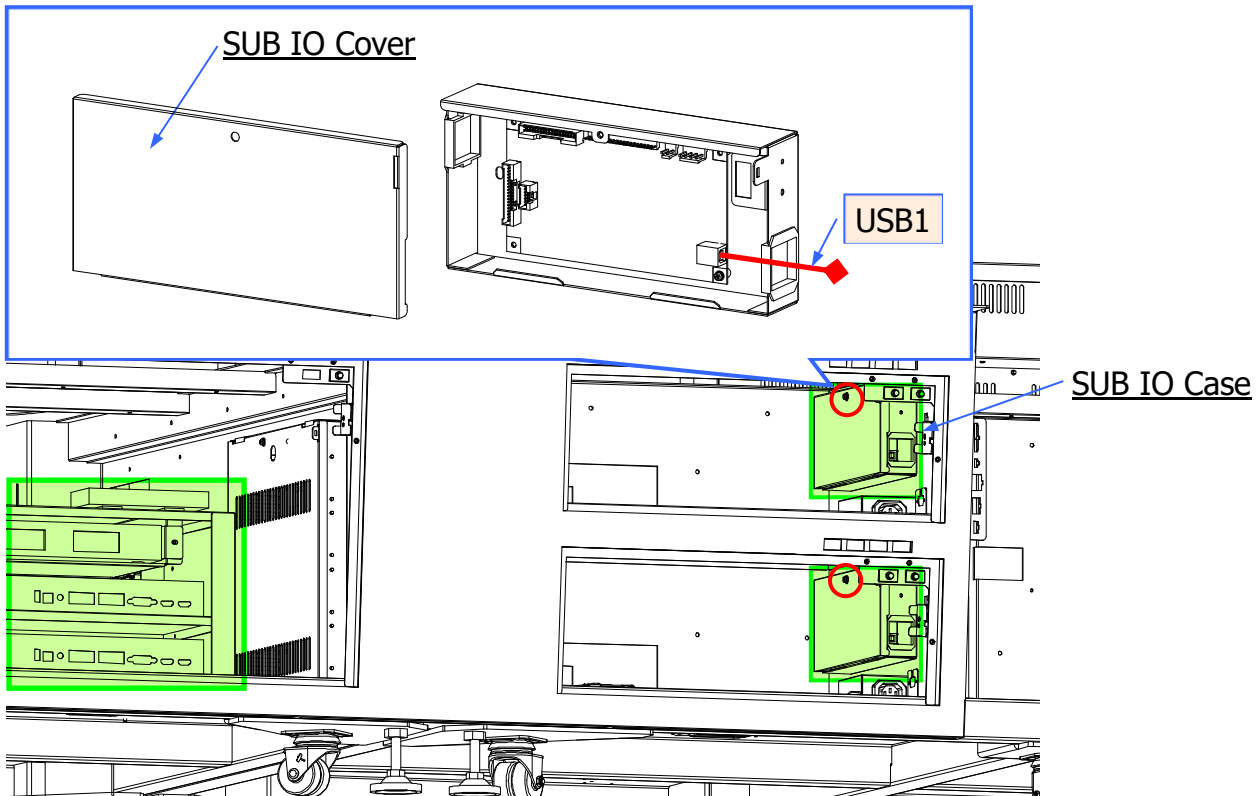

NOTE:

If the Counter (Option) is included, connect D4C(x2) Connectors of the Bottom LED Cover C Unit, that were checked at **STEP 9**, to each AX-SUB IO PCB.

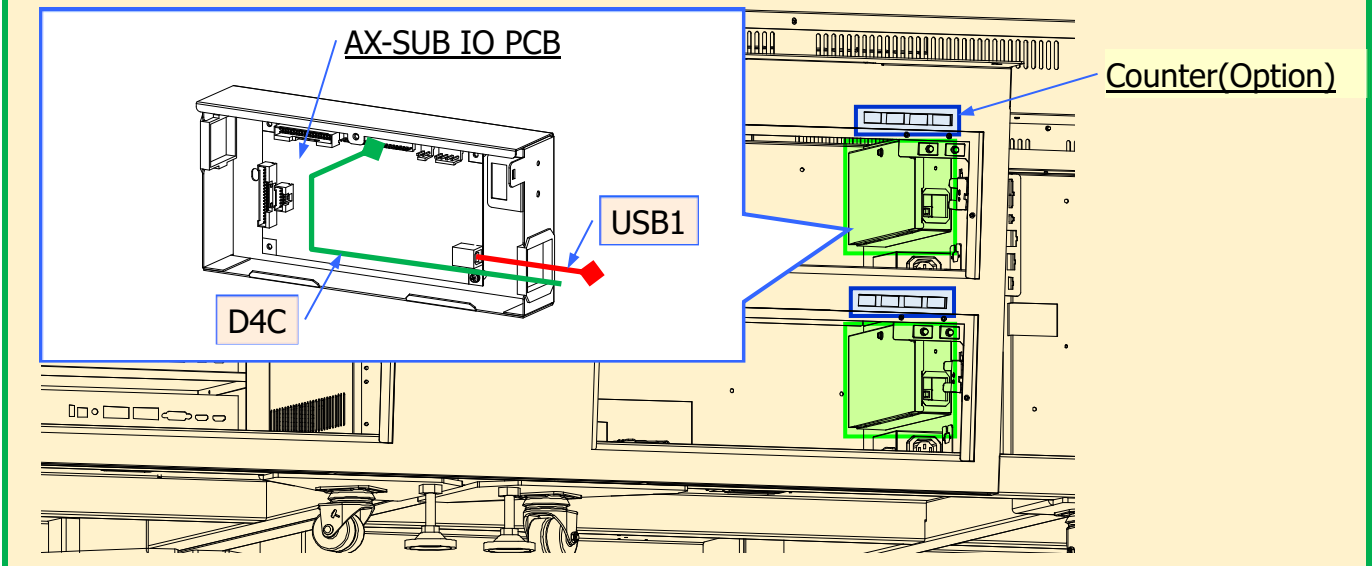

14. Follow the same procedure to pull out the USB1 Connector of all the SUB IO Cases that are located in the 8 Shelves of the Center Unit indicated below.

i NOTE:

If the Counter (Option) is installed, the 8 D4C Connectors in the positions indicated below are already connected.

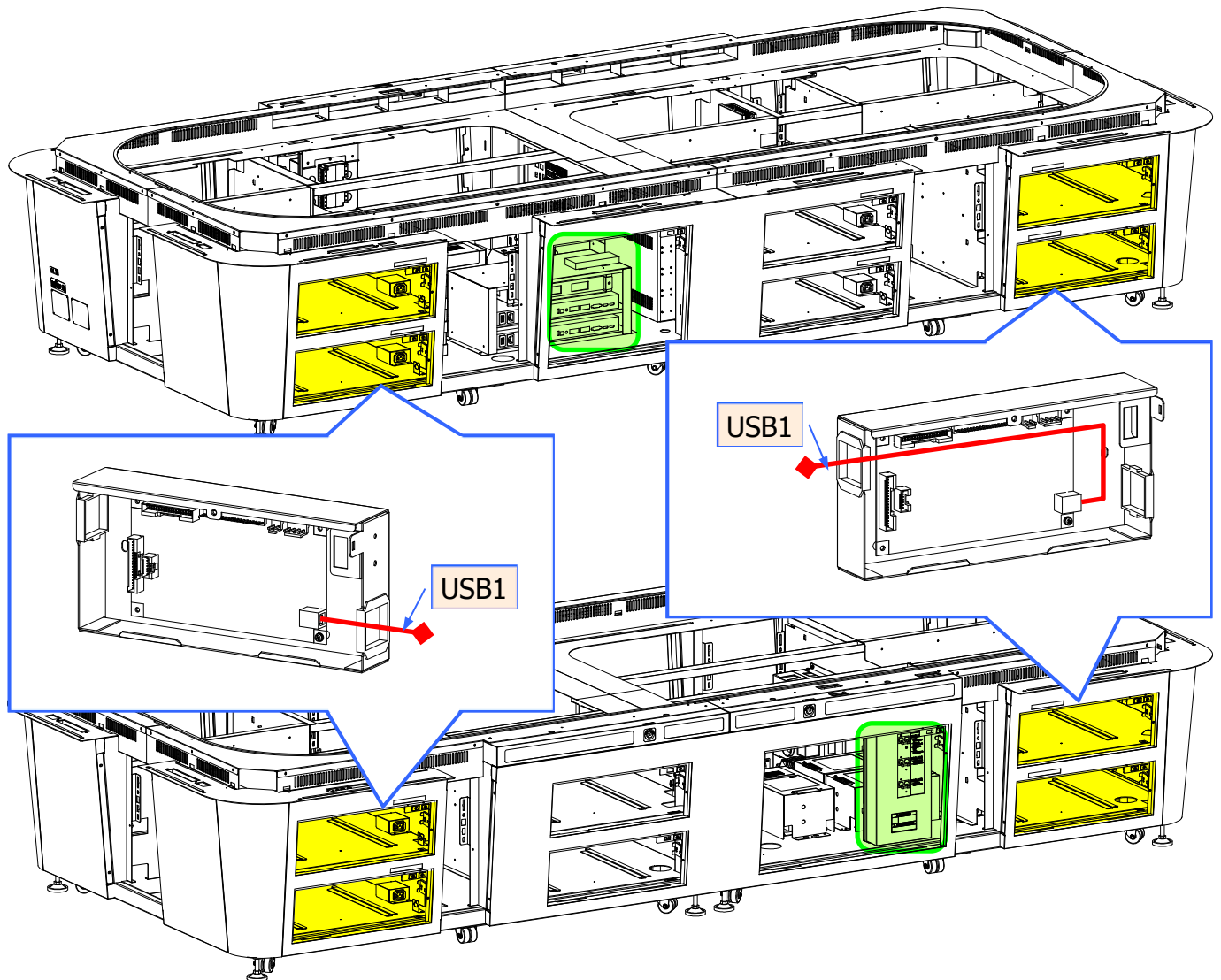

3. 2. 3: Hardware setting for whole the Machine

Hardware Settings are necessary for factory shipped products to be operational. Before commencing with operation, make sure to do the settings explained below.



CAUTION!

Hardware Settings must be done by authorized personnel.

3. 2. 3. 1: Center Unit

- Location of PCBs -

The PCBs that require setting are shown below inside a frame.

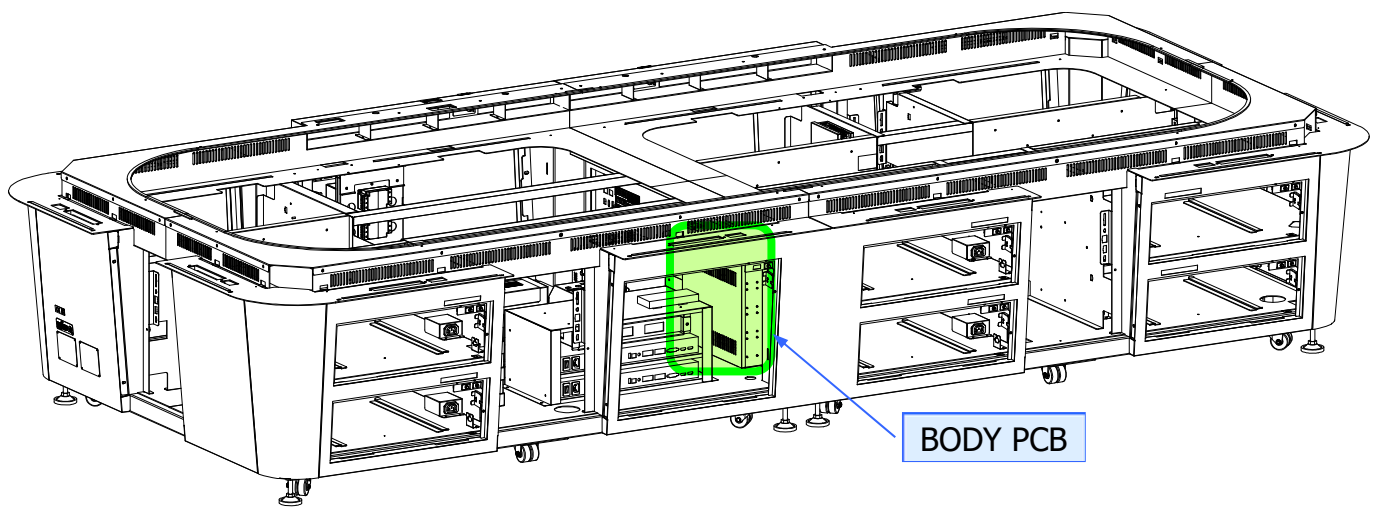

- BODY PCB -

PCB	Onboard Switch/Jumper	Factory Setting	Setting for Operation	Description
BODY PCB	SW2(2 Bit Dip Switch)	All OFF (Invalid)	All ON	The switch for enabling the Backup Battery

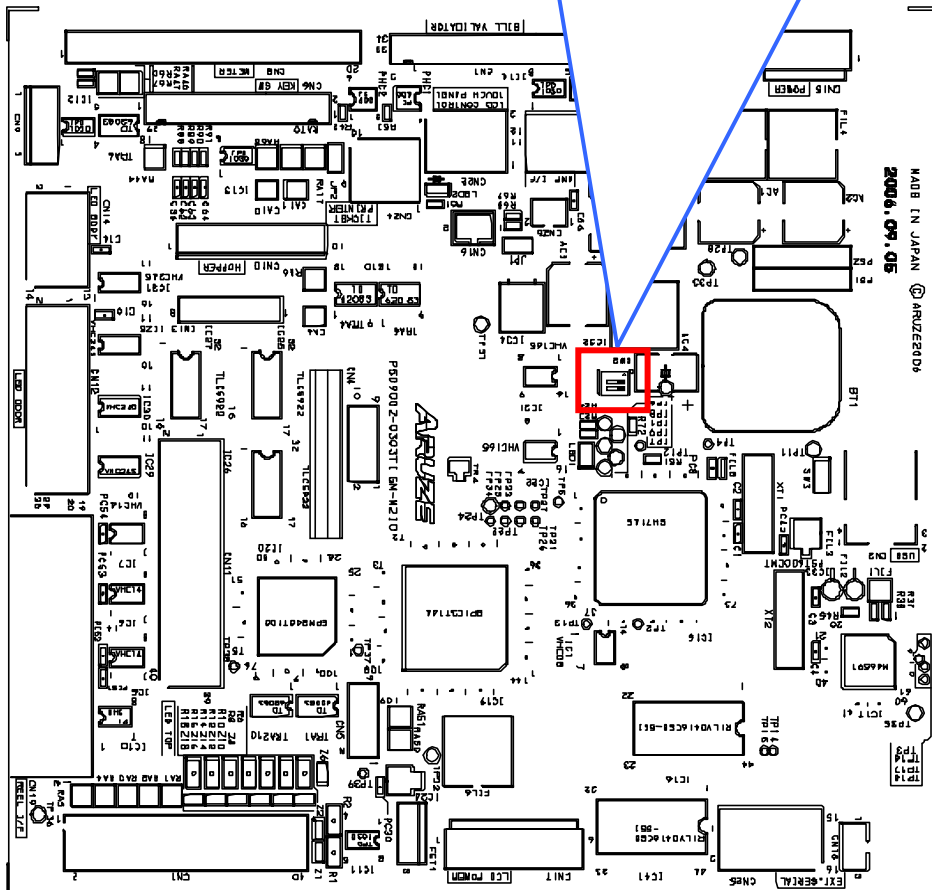
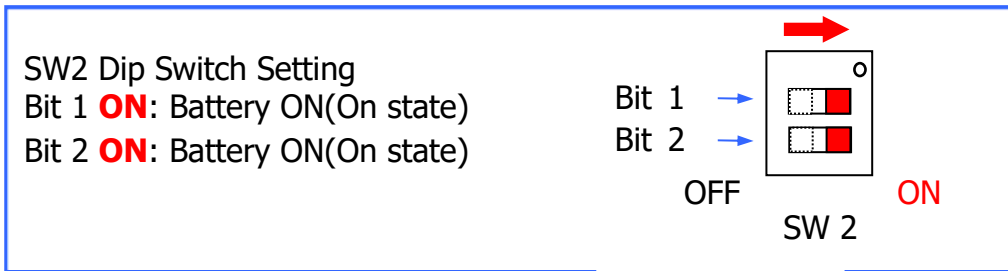
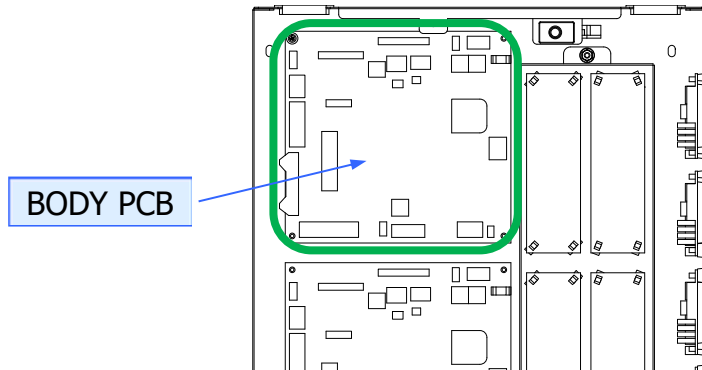

3. 2. 3. 2: Controller Units (Signage, Main, Station)

1. Prepare the following Parts. (Refer to 3.2.2)

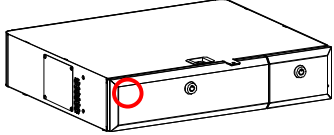
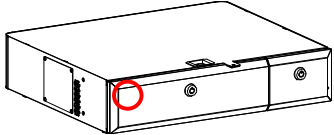
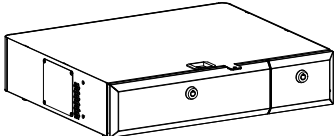
Parts Name	Qty	Appearance
Signage Controller Unit (※can be identified by the ID Sticker) The Key Board can be an obstacle to the procedures, so remove it temporarily.	1	
Main Controller Unit (for Dealer Terminal) (※can be identified by the ID Sticker)	1	
Station Controller Unit (for Player Terminal No.1~No.10) (※no sticker attached)	10	

i NOTE:

All the 12 Controller Units listed above, which are installed inside the Center Unit on this machine, should be set in the same way.

- Location of PCBs -

The PCBs that require setting are shown below inside a frame.

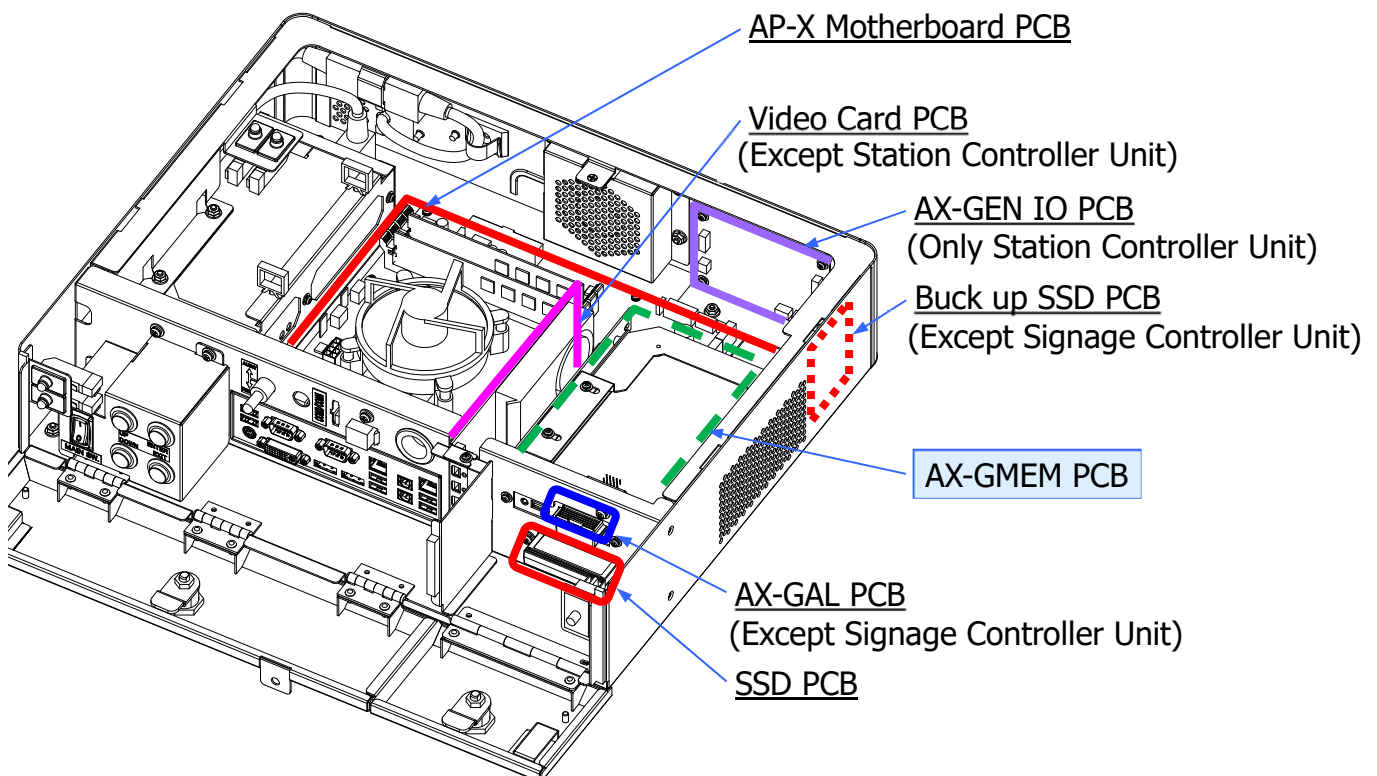

- AX-GMEM PCB -

PCB	Onboard Switch/Jumper	Factory Setting	Setting for Operation	Description
AX-GMEM PCB	S2 (Slide Switch)	Front (Battery OFF)	Back (Battery ON)	The switch for Backup Battery ON-OFF

To have access to the Slide Switch of the AX-GMEM PCB, please refer to "AX-GMEM PCB Unit of Controller Unit" at next page.

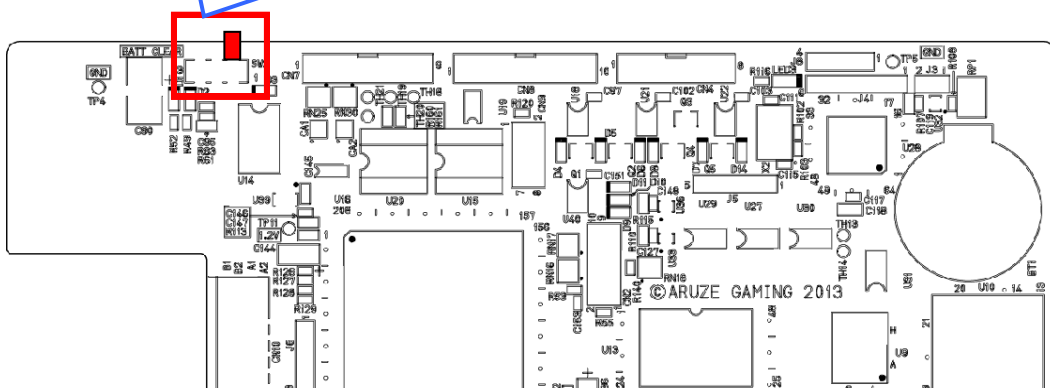
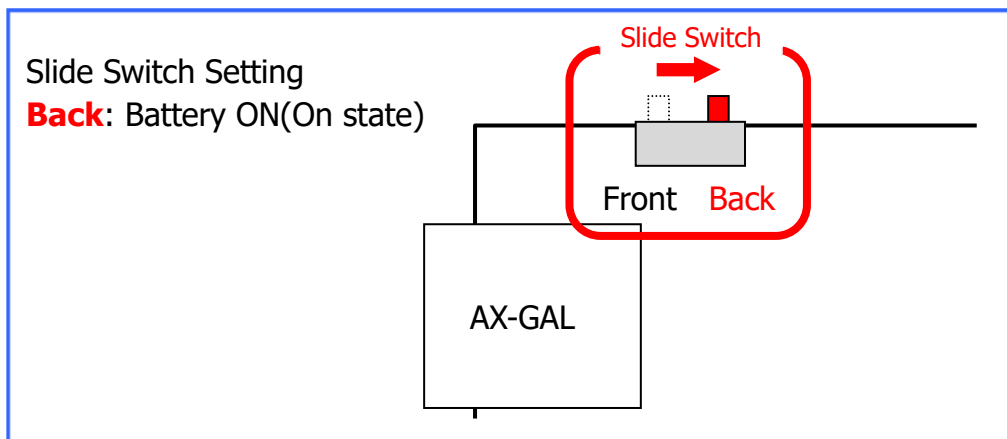
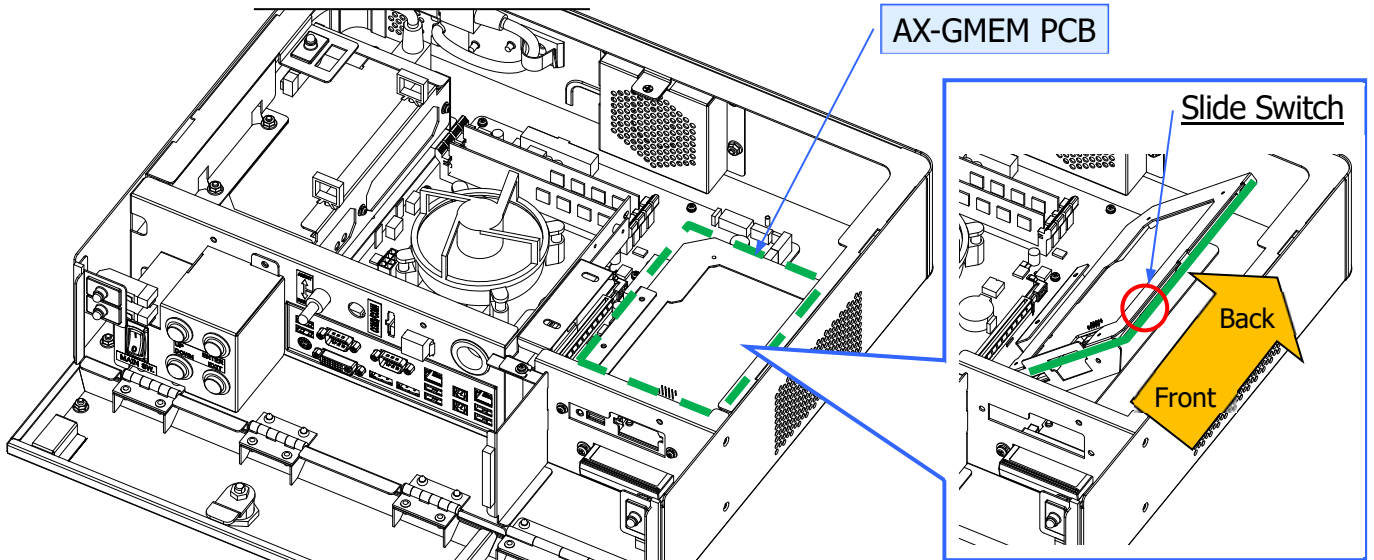

AX-GMEM PCB Unit of Controller Unit**⚠ WARNING!**

Electrostatic discharge may damage internal components. When accessing the inside of the Cabinet, take anti-static measures (as wearing anti-static wrist band etc.) before proceeding.

1. Unlock the Main Door Lock and the Security Door Lock of the Controller Unit, and open them.

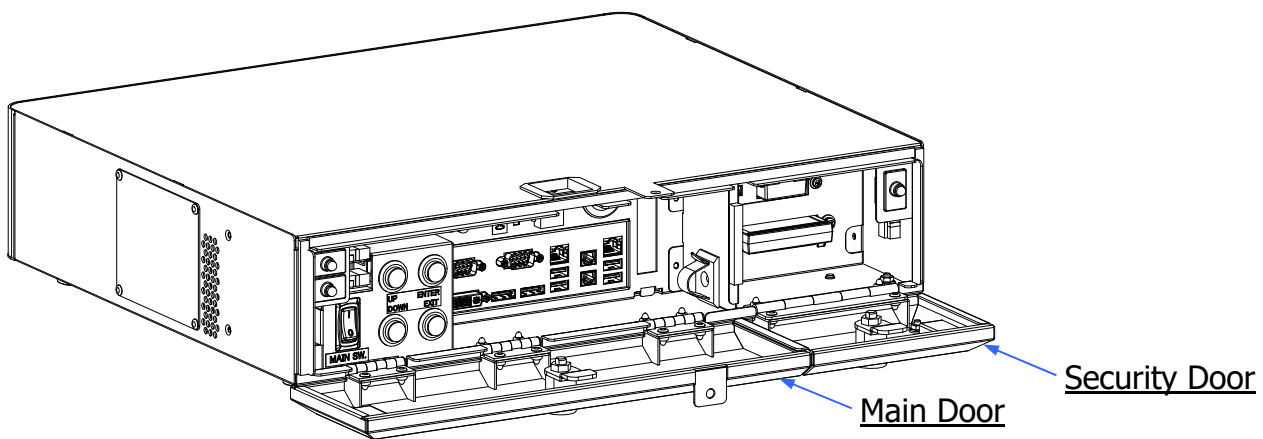

2. Remove the 3 fasteners on the front side of Controller Unit.

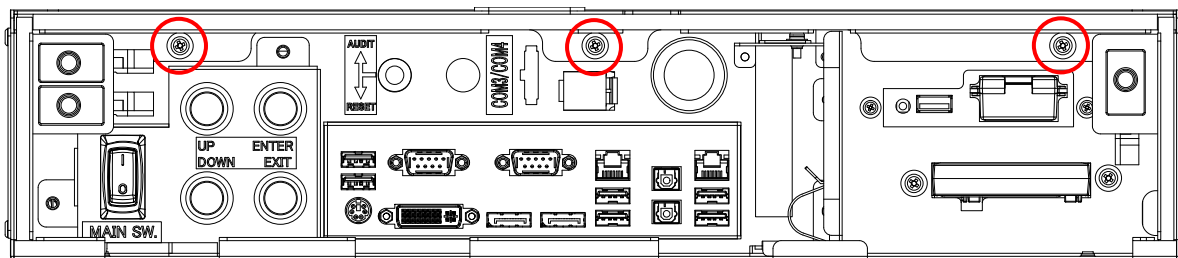

- Slide toward the front side the Side Slide Door(Top Cover). Free the hooks and detach the Side Slide Door(Top Cover).

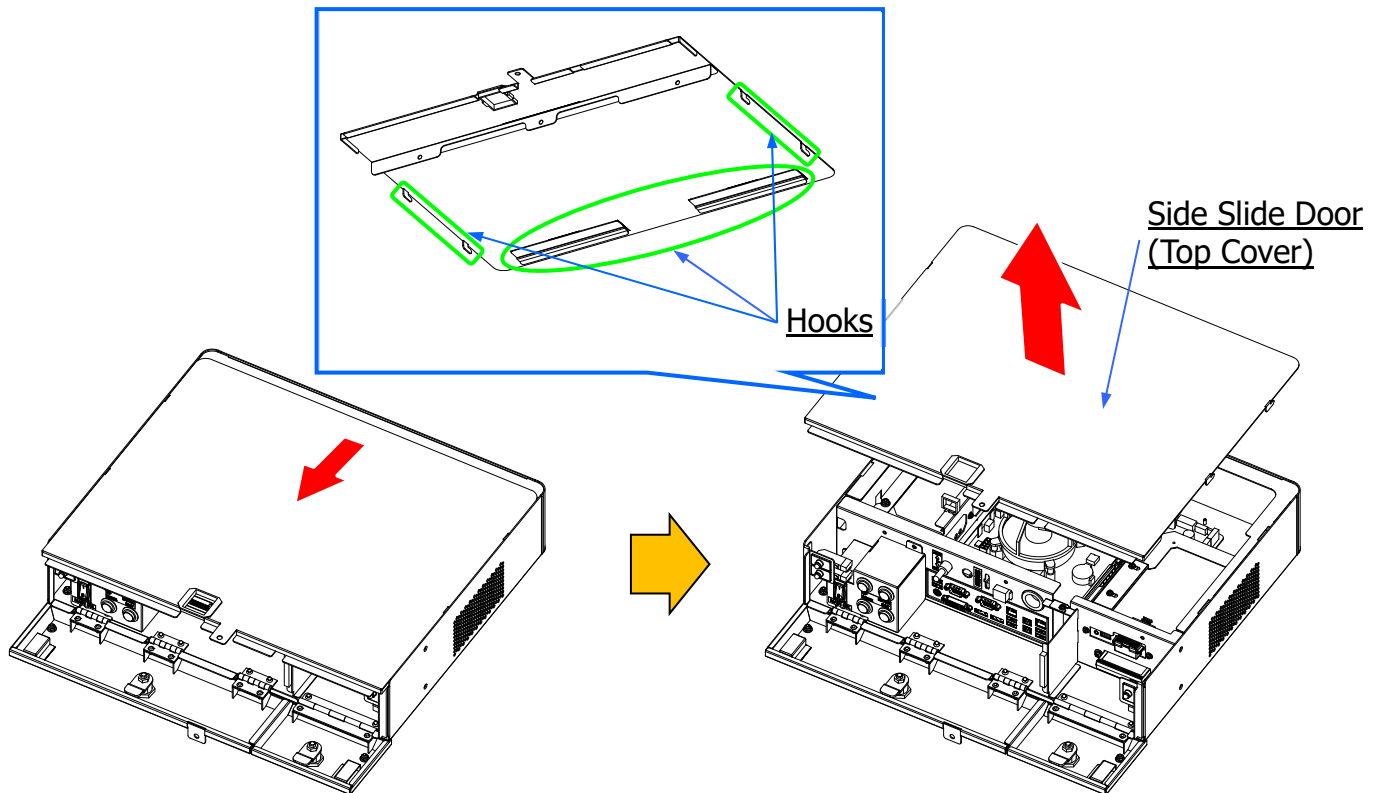

- Remove the AX-GAL(Game GAL) Cassette currently inserted into the machine.

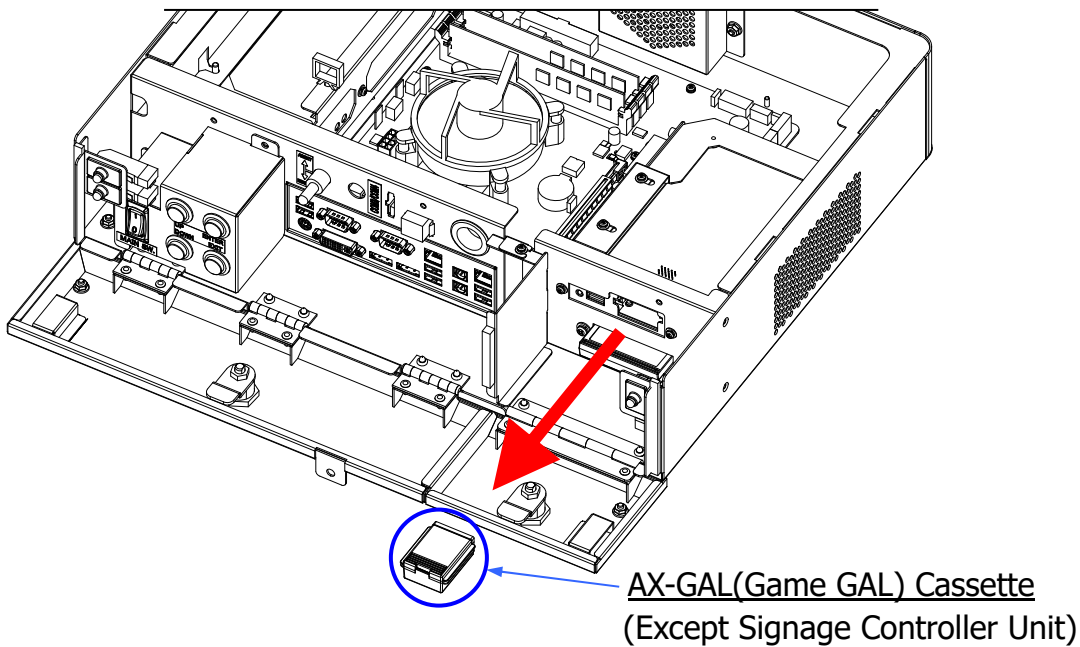

5. Remove the 2 RISER BRKT fasteners. Disconnect the Flat Cable connected to the RISER BRKT and, while holding the AX-GMEM PCB Unit with one hand, remove the RISER BRKT.

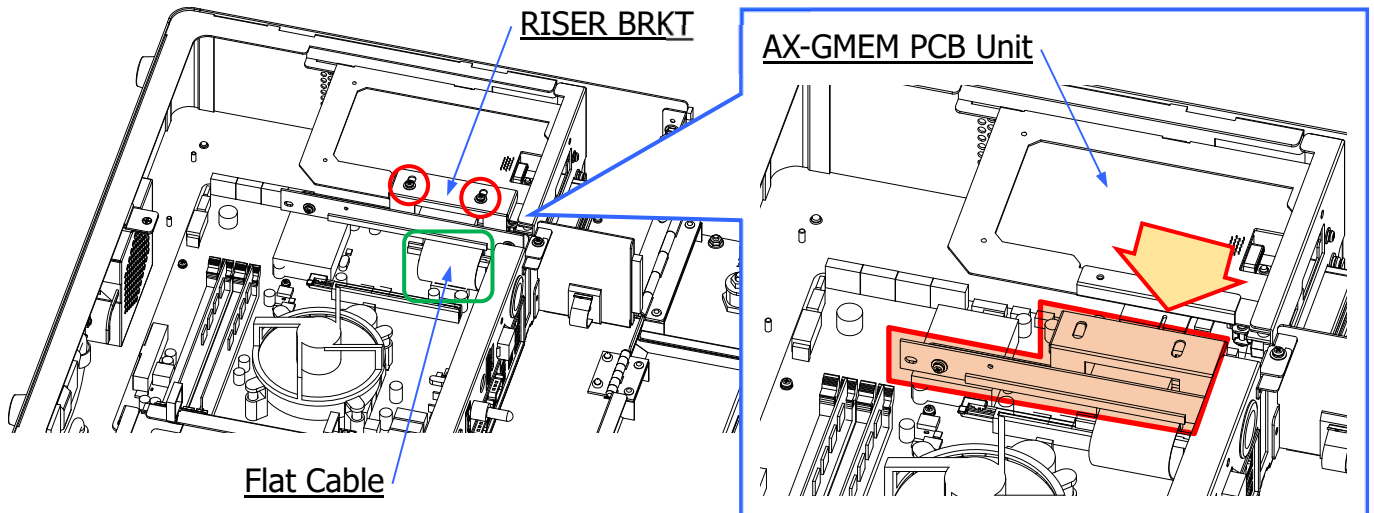

6. Remove the 2 fasteners on the front side of the Controller Unit. Slide toward the back side the AX-GMEM PCB Unit to free the hook on the right side. It is possible to remove the AX-GMEM PCB Unit by extracting the harness connected to the connector on the back side.

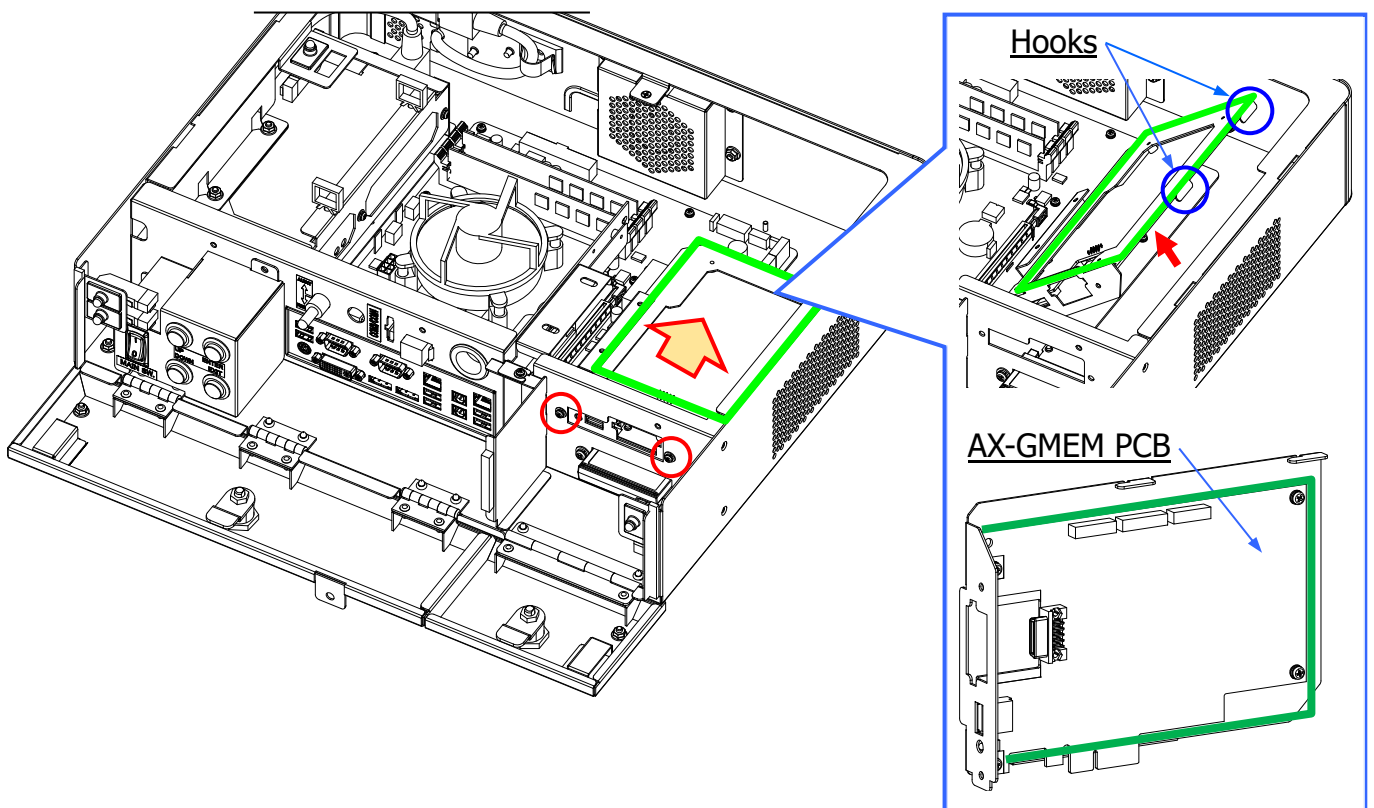

3. 2. 4: Installing the Controller Units

1. Prepare the following Parts.

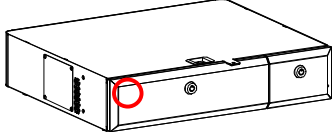
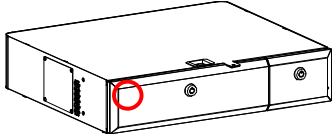
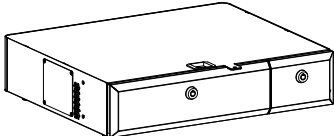
Parts Name	Qty	Appearance
Signage Controller Unit (Setted in 3.2.3.2) The Key Board can be an obstacle to the procedures, so remove it temporarily.	1	
Main Controller Unit (for Dealer Terminal) (Setted in 3.2.3.2)	1	
Station Controller Unit (for Player Terminal No.1~No.10) (Setted in 3.2.3.2)	10	

i NOTE:

If the locks of the Controller Unit are changed for increased security, please refer to "Key Locks" on Chapter 2 and Chapter 3 of the SERVICE MANUAL to perform the work.

- Refer to the chart below to place correctly on the shelves of the Center Unit each of the 12 Controller Units, including those identified by the ID Stickers for Signage and Main.

i NOTE:

The Signage Controller Unit is placed in the upper shelf, the Main Controller Unit is placed in the lower shelf.

An ID Number will be set To the Station Controller Units (without any sticker) later, when the machine is booted up, so they can be placed in any of the empty shelf indicated in yellow.

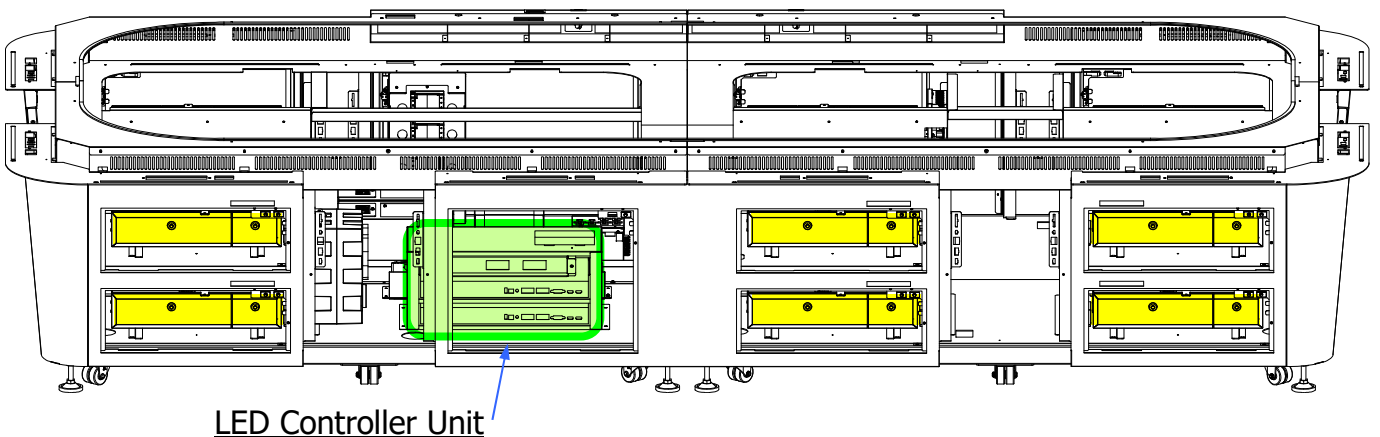
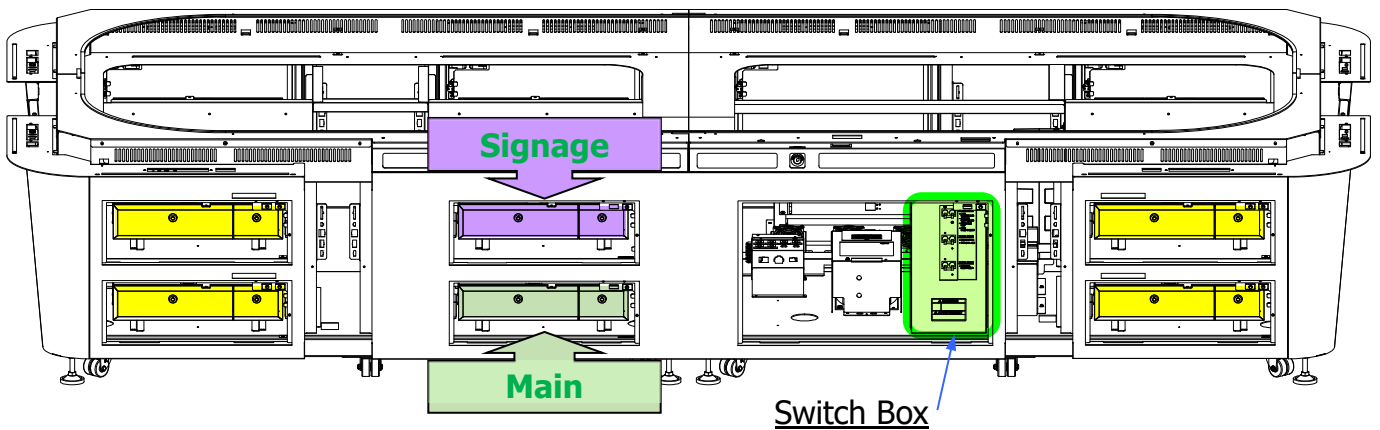
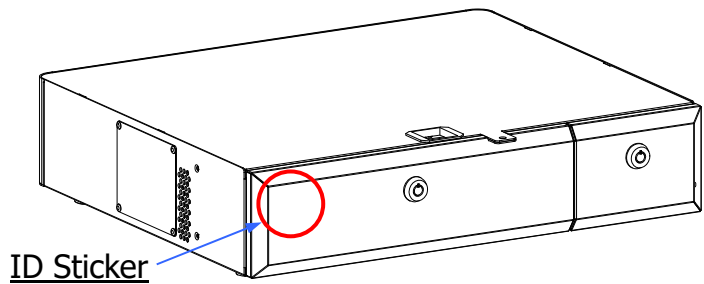

Signage Controller Unit

- A) Locate the MDP1, MDP4 and SN Connectors that are arranged on the shelf for the Signage Controller Unit, and untie them.
- B) Connect the AC Cable on the back side of the Signage Controller Unit to the AC Socket on the shelf for the Signage Controller Unit, and then install the Signage Controller Unit while paying attention not to pinch the cable.

i NOTE:

The Key Board can be an obstacle to the procedures, so remove it temporarily.

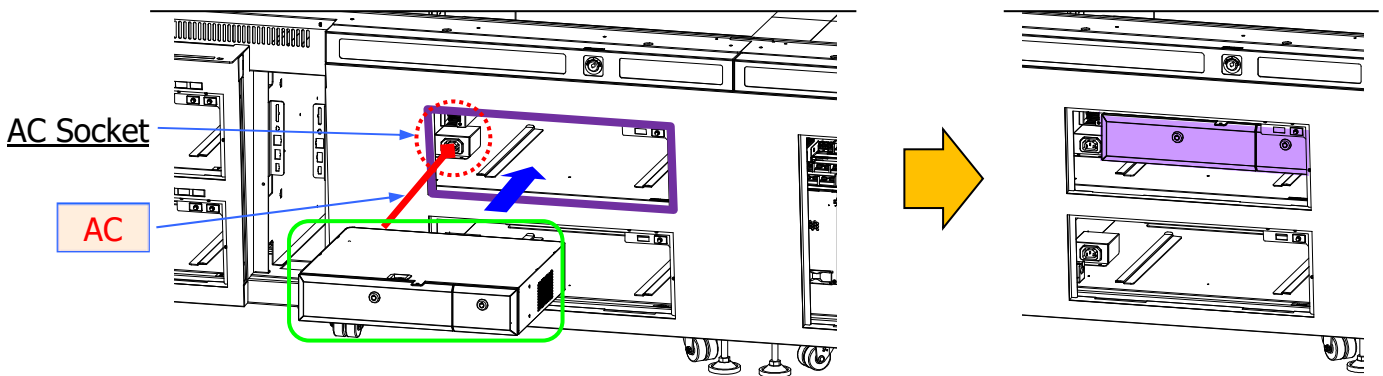

- C) Unlock the Main Door Lock of the Signage Controller Unit, and open it.

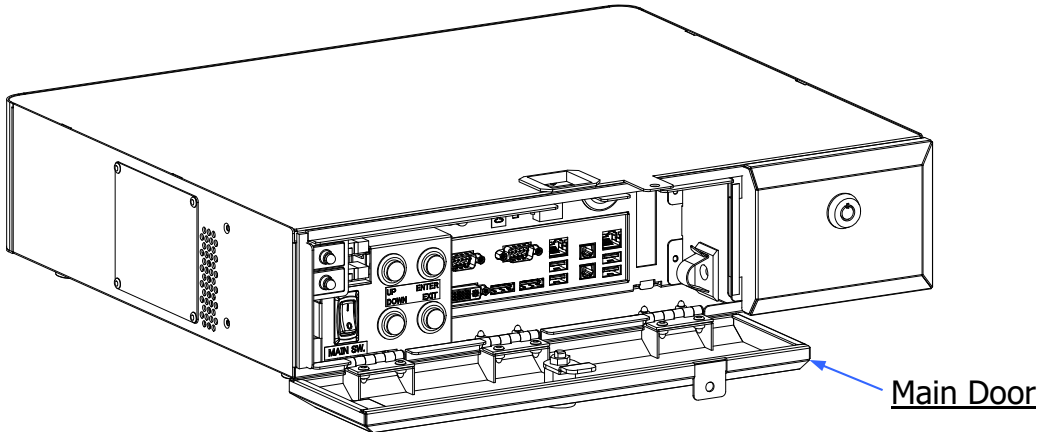

- D) Refer to the chart below and connect the MDP1, MDP4, HDP, ARP and SN connectors of the Center Unit to each of the connectors inside the Signage Controller Unit.

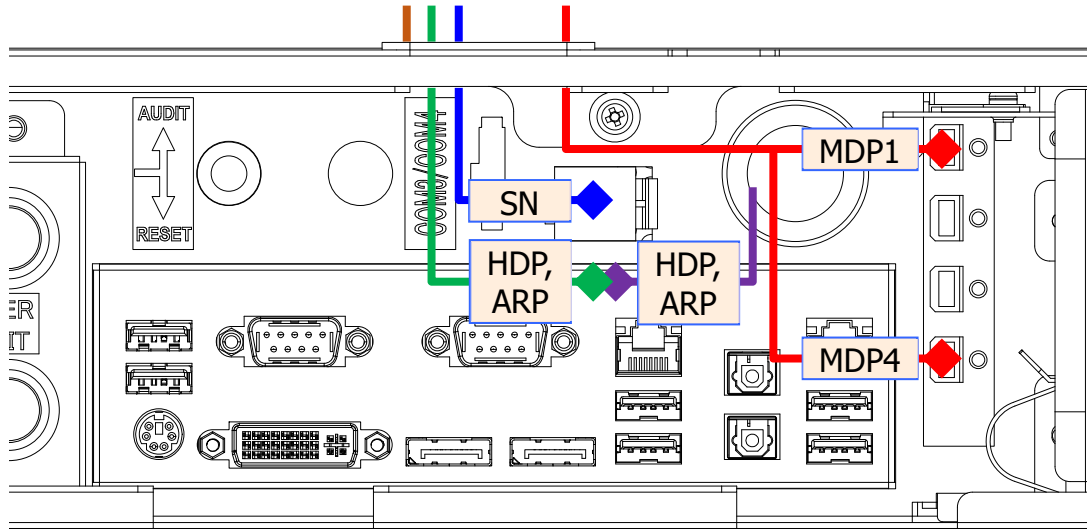

- E) Refer to the chart below and connect the USB Connector of the Keyboard to the USB0 Connector of the Signage Controller Unit, and place the Keyboard on top of the Signage Controller Unit.

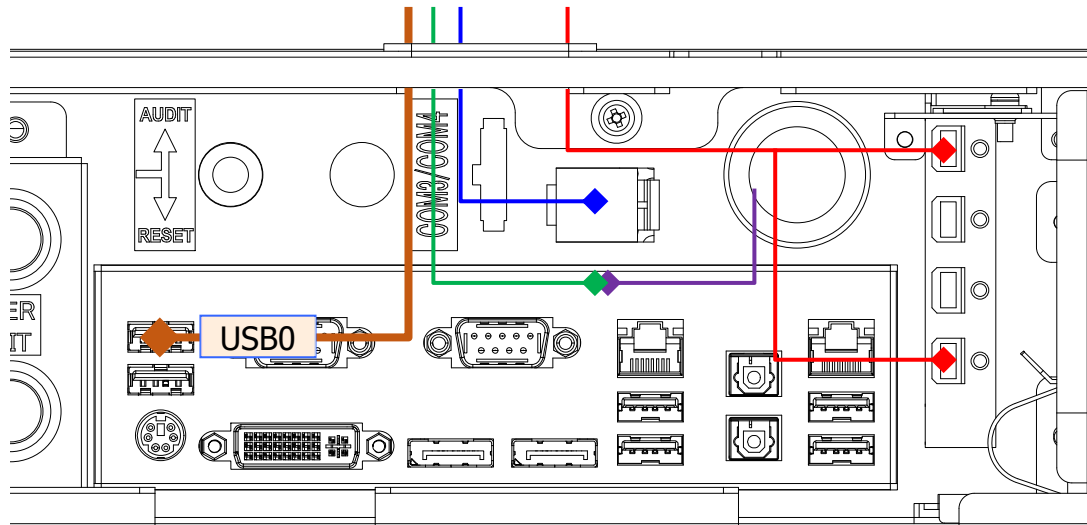

- F) Check that the Switch of the Controller Unit is turned to ON, and then close the Main Door while paying attention to the cables and connectors.

⚠ CAUTION!

Please leave these switches on ON and do not change their status.

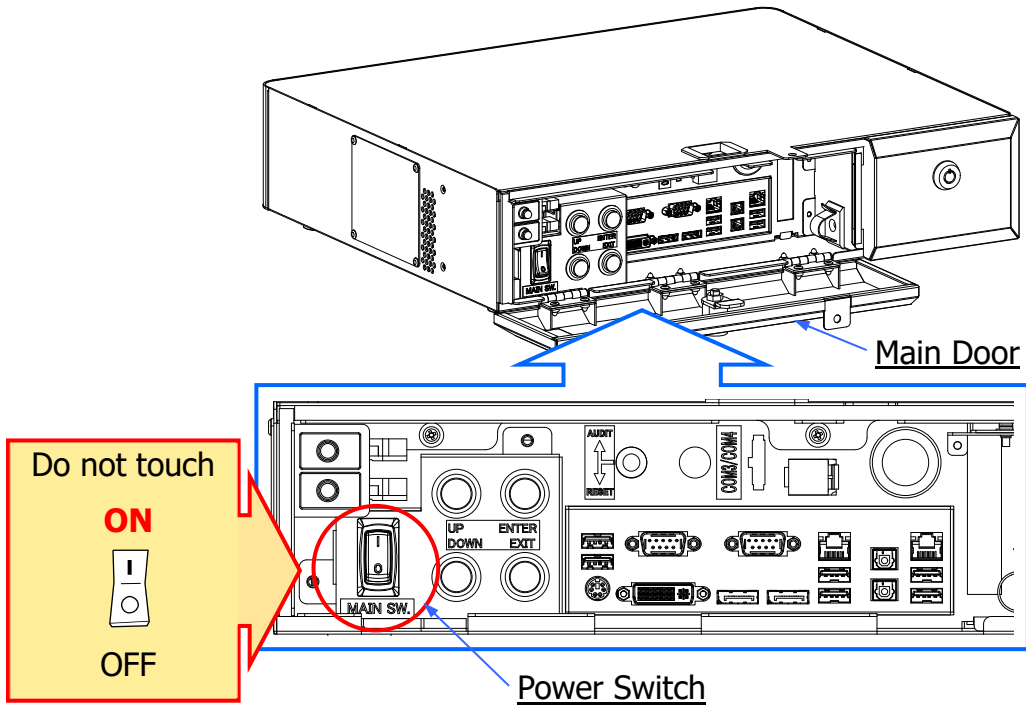

i NOTE:

Return the Key Board that was removed to its original position.

Main Controller Unit

- A) Locate the MDP1, MDP2, MDP3, HDP, ARP, MS, USB0, USB1 and USB2 connectors that are arranged in the shelf for the Main Controller Unit, and then untie them.
- B) Connect the AC Cable on the inner side of the Main Controller Unit to the AC Socket on the shelf for the Main Controller Unit, and then install the Main Controller Unit while paying attention not to pinch the cable.

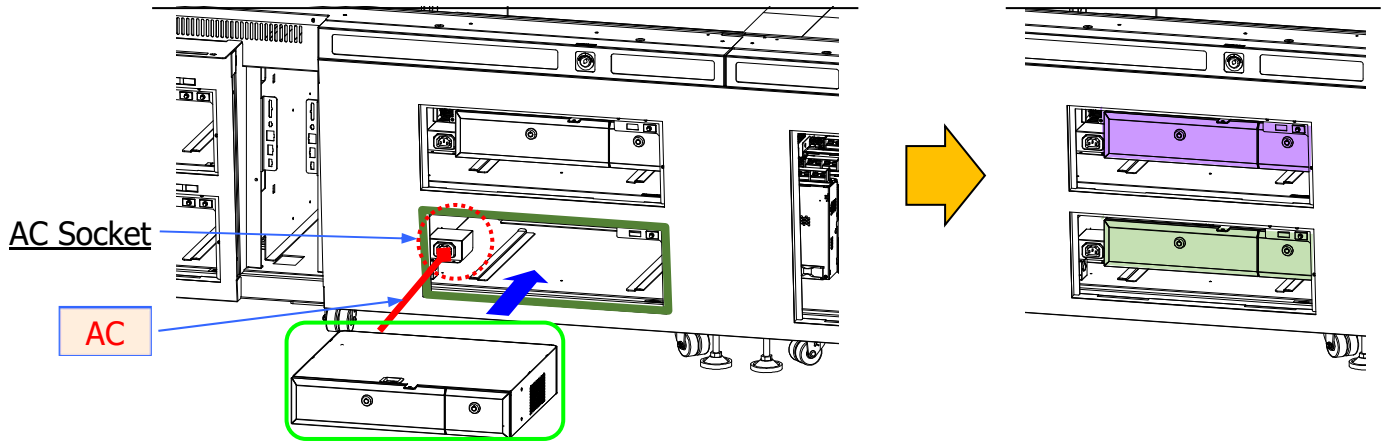

- C) Unlock the Main Door Lock of the Main Controller Unit, and open it.

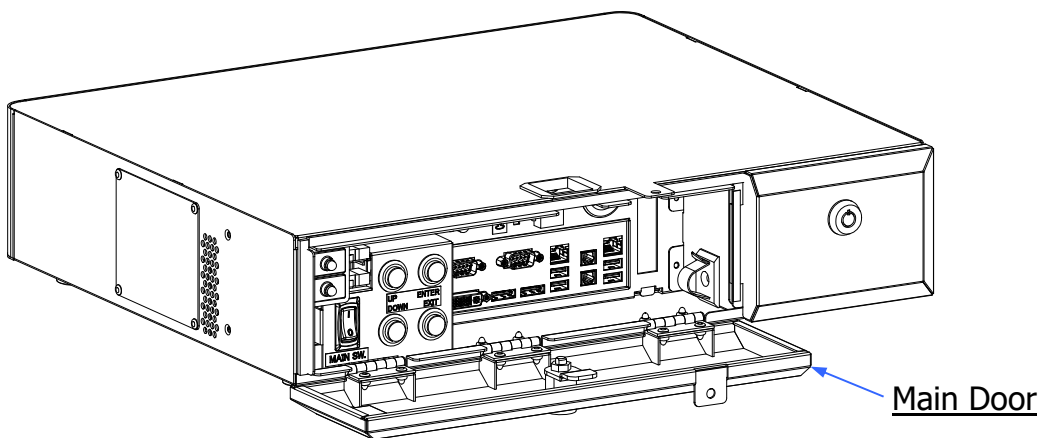

- D) Refer to the chart below and connect the MDP1, MDP2, MDP3, HDP, ARP, MS, USB0, USB1 and USB2 connectors of the Center Unit to each of the connectors inside the Main Controller Unit.

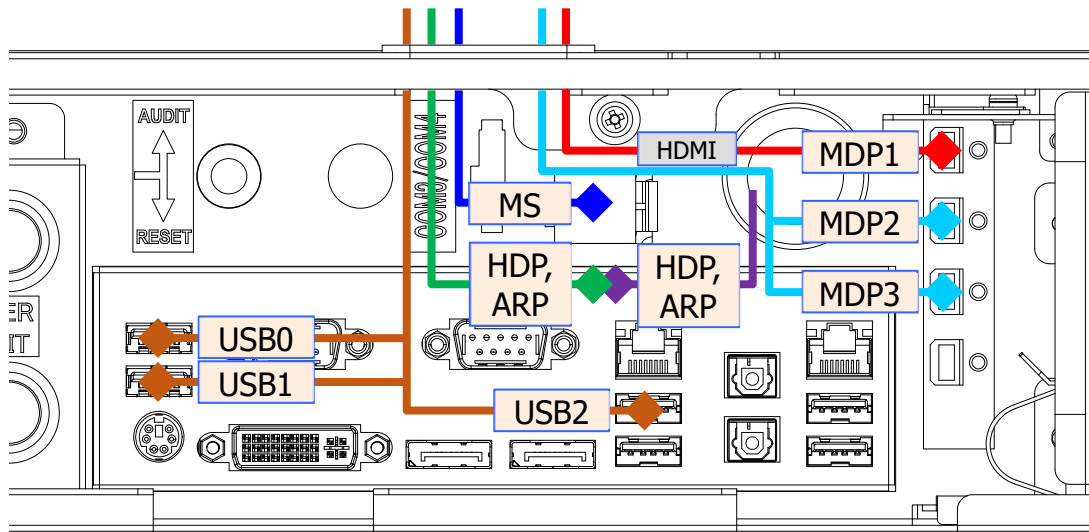

- E) If the CM2 (GAT3) Connector is included, connect it to the Connector indicated below.

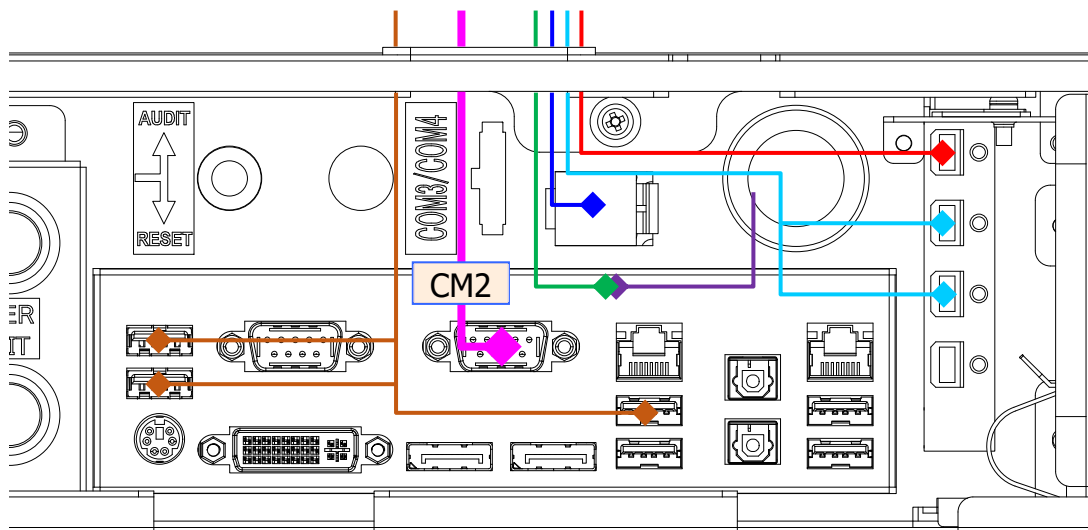

- F) Check that the Switch of the Controller Unit is turned to ON, and then close the Main Door while paying attention to the Cables and Connectors.

CAUTION!

Please leave these switches on ON and do not change their status.

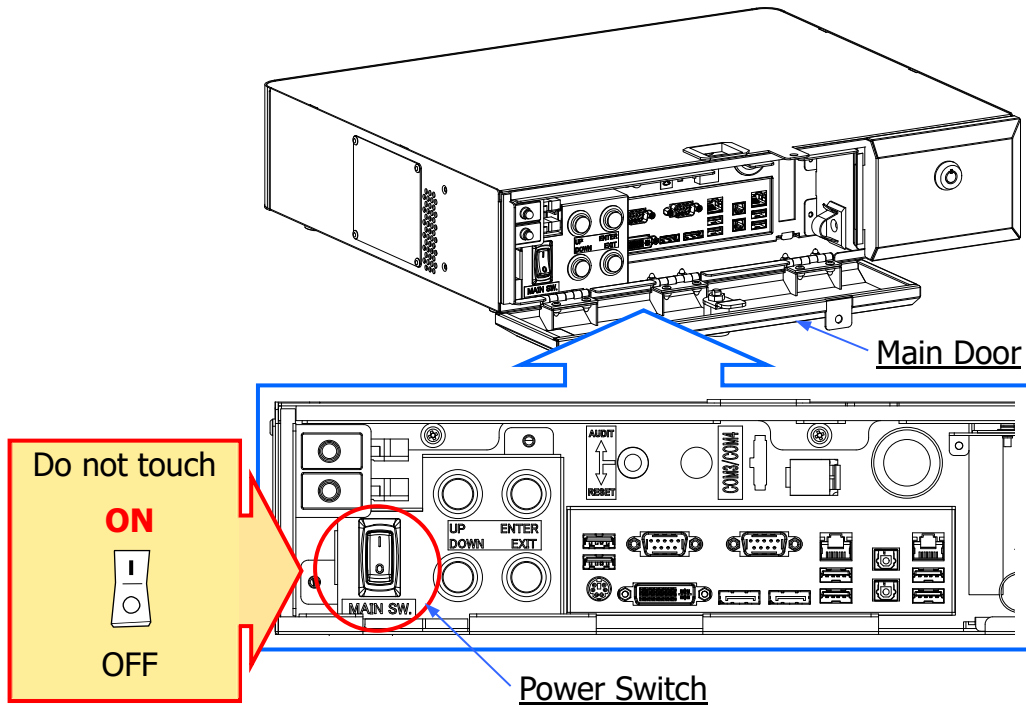

Station Controller Unit(No.1~No.10)

i NOTE:

Place the Controller Units without sticker on the shelves for the Station Controller Unit.
Refer to **STEP 2**.

- A) Locate the DP1, PVC, SVD, ARP, SWB, GO, Txx, USB0 and USB1 Connectors that are arranged on the shelf for the Station Controller Unit, and untie them.
- B) Connect the AC Cable on the inner side of the Station Controller Unit to the AC Socket on the shelf for the Station Controller Unit, and then install the Station Controller Unit while paying attention not to pinch the cables.

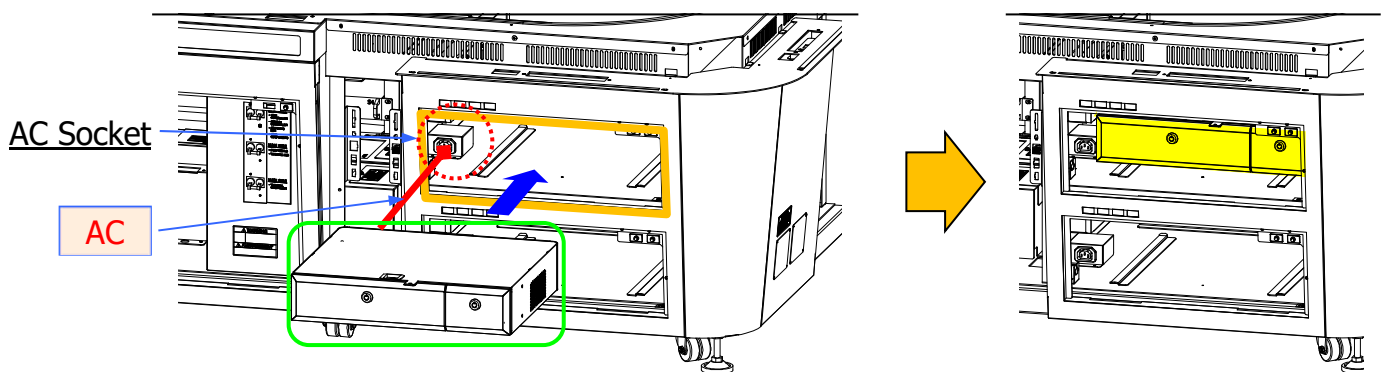

- C) Unlock the Main Door Lock of the Station Controller Unit, and open it.

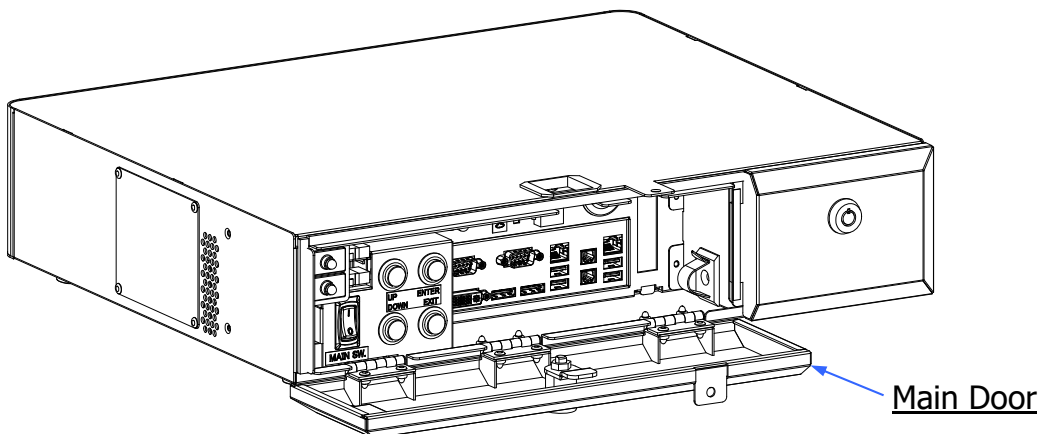

- D) Refer to the chart below and connect the DP1, PVC, SVD, ARP, SWB, GO, Txx, USB0 and USB1 connectors of the Center Unit to each of the connectors inside the Station Controller Unit.

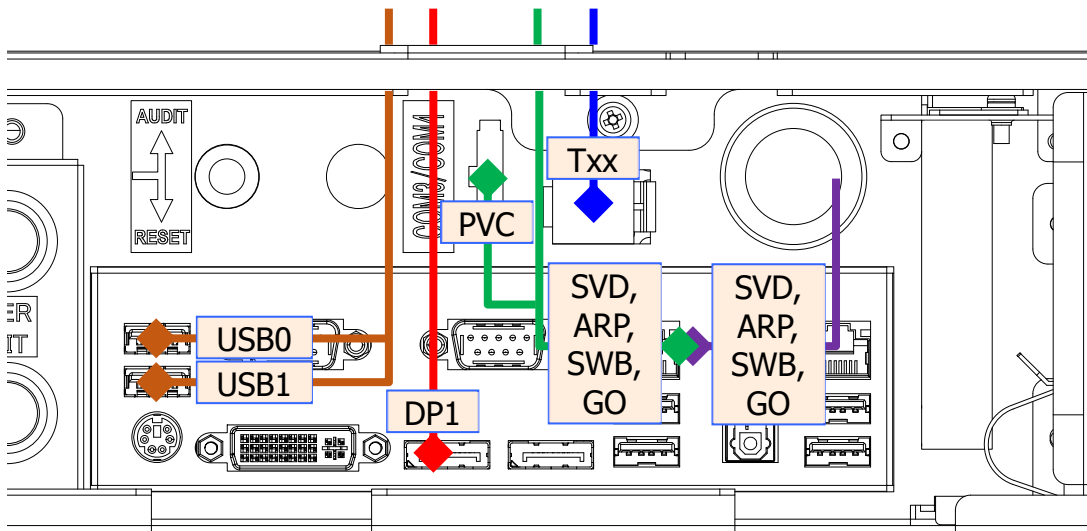

- E) If the CM1(SAS), RX, CM2 (GAT3) Connectors are included, connect them to each of the connectors indicated below.

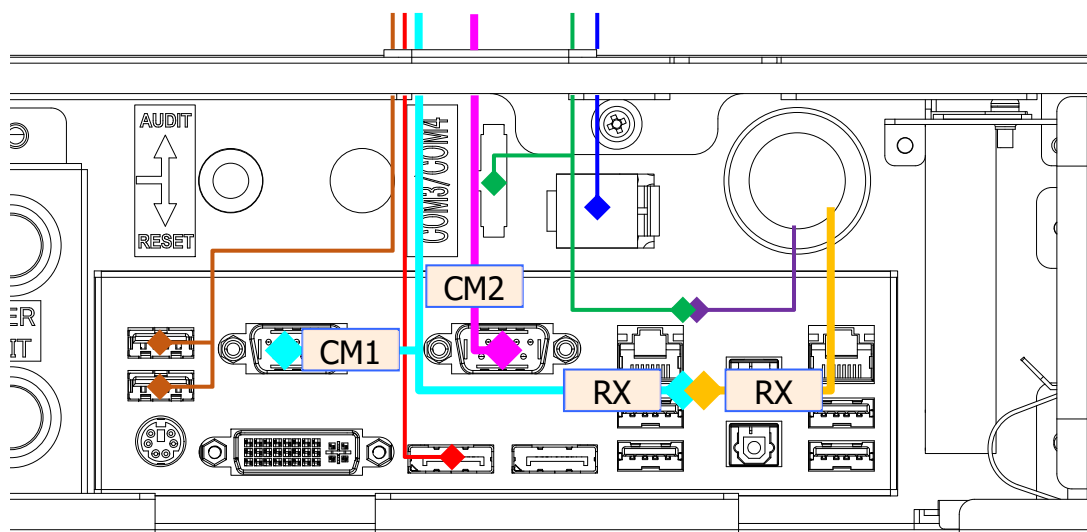

- F) Check that the Switch of the Controller Unit is turned to ON, and then close the Main Door while paying attention to the Cables and Connectors.

CAUTION!

Please leave these switches on ON and do not change their status.

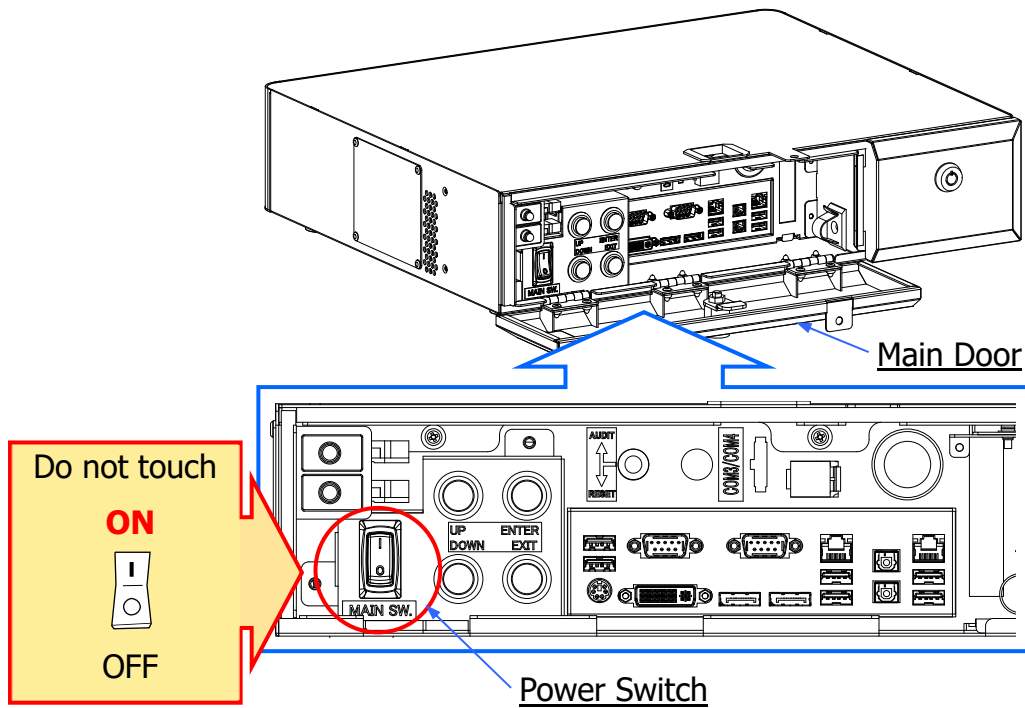

3. 2. 5: Installing the Field LED Unit

1. Remove the 36 screws around the Center Unit, and then detach the LED Panel Cover A, B, C and D and store them with the screws.

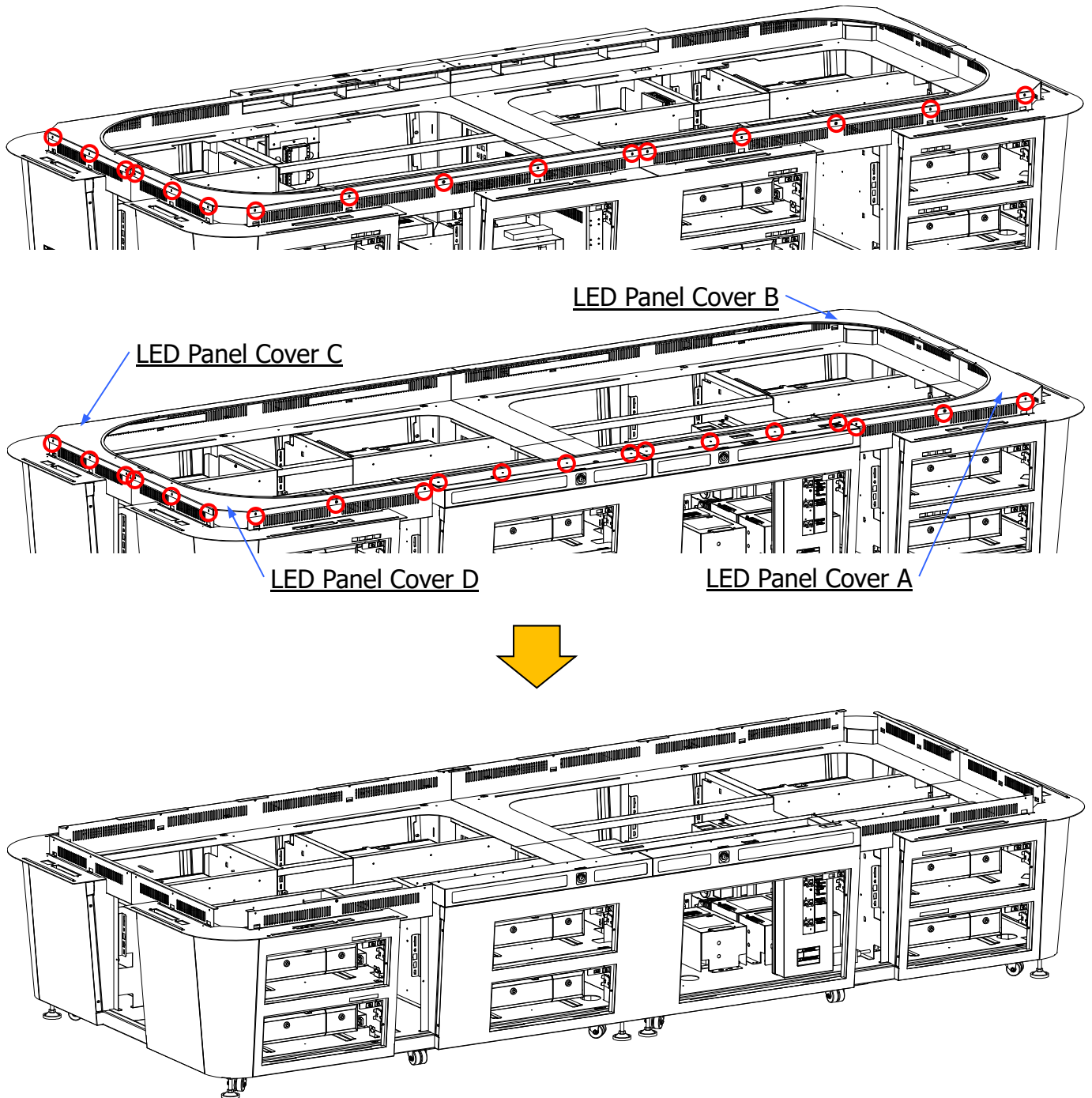

- Untie the 2 AC Cables from the LED Controller Unit that are arranged inside the Center Unit, lead them through the hole on the bottom side indicated by the chart below, and connect them to the previously prepared power suppliers.

**CAUTION!**

- Do not electrify the Power Source.
- Make sure that the Switches of the LED Controller Unit are switched to ON. **Please leave this switch on ON and do not change its status.**

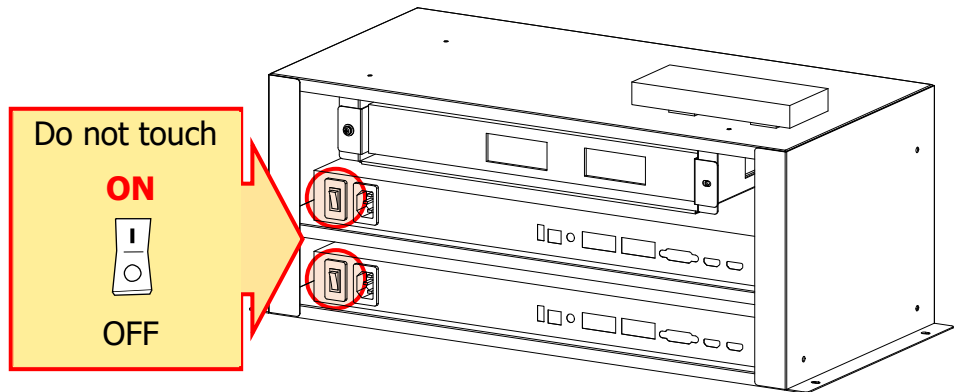

LED Controller Unit

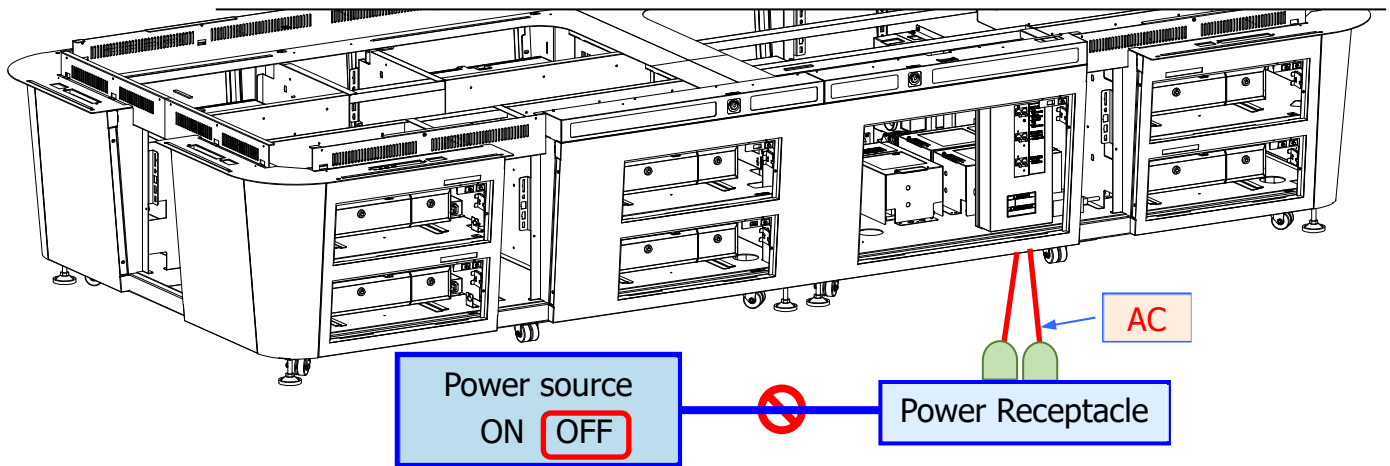
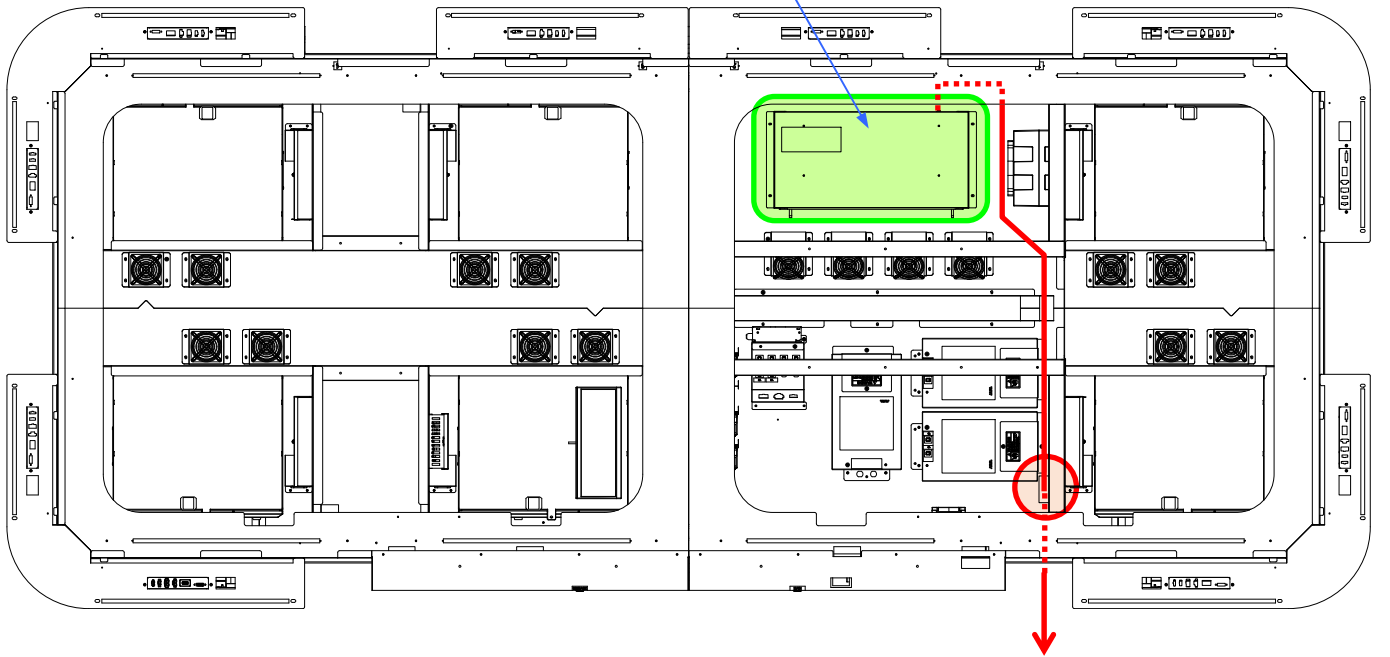

i NOTE: Option-2

In case it was chosen the Option to use the Tipping System Unit (Option), from this point refer to the procedures indicated as **Option-2**. If this Option was not chosen, continue to **STEP 3**.

Option-2 - 1

- A) Locate the PVC Connector that is arranged inside the Center Unit A, then untie it and pass it to Center Unit B.

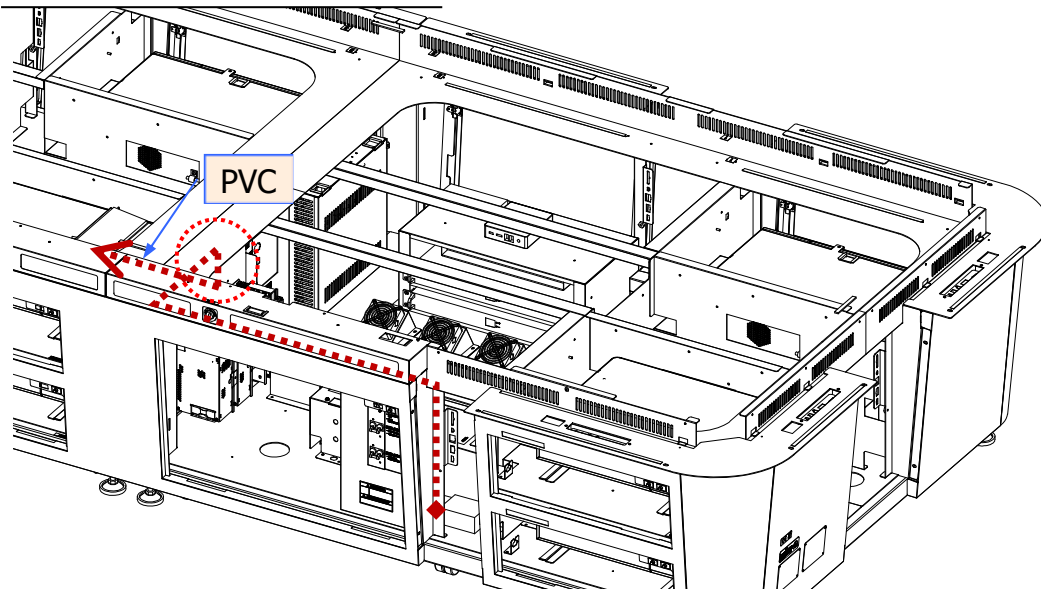

- B) Refer to the illustration below to pass the connector inside the shelf of the Main Controller Unit.

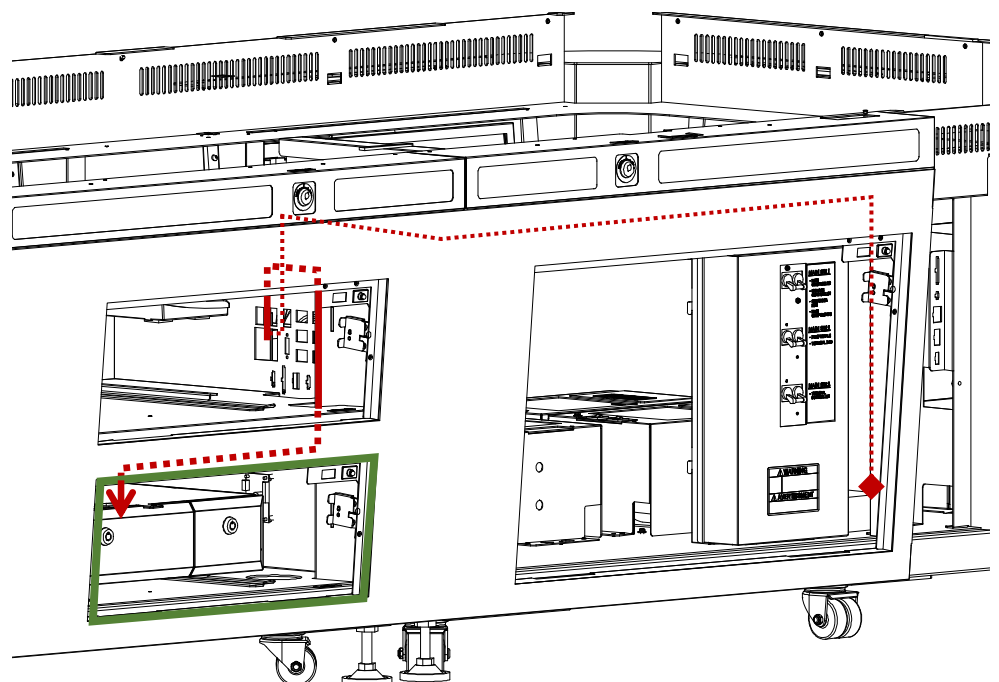

C) Refer to the illustration below to connect the PVC Connector to the Connector inside the Main Controller Unit, then close the Main Door.

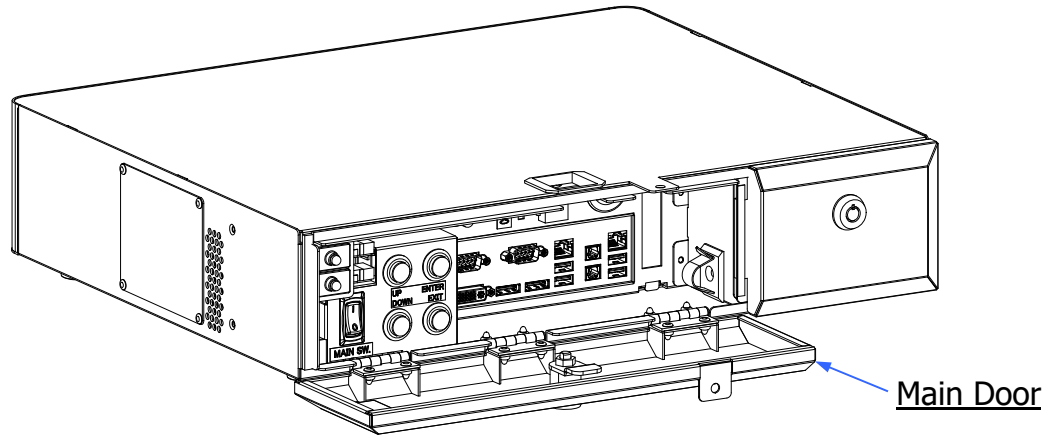
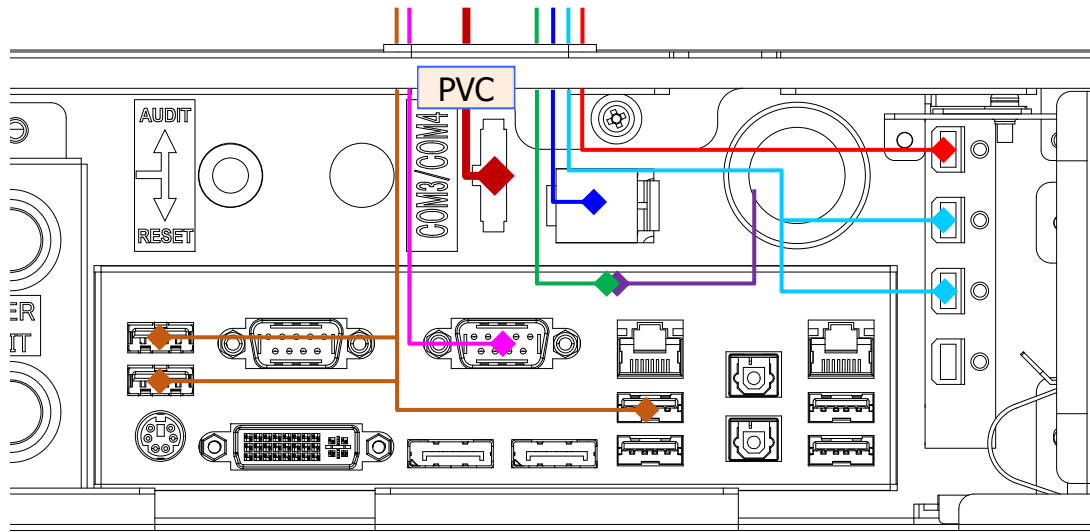

D) Prepare the following Parts.

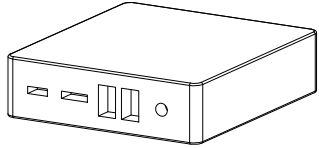
Parts Name	Qty	Appearance
<ul style="list-style-type: none"> · SMALL PC LIVAZ-4/32 (N3350) · 12V AC/DC Adapter(for SMALL PC) · Ring Fix Tape ※It may be fixed to the LED Controller Unit. 	1	

- E) Place the SMALL PC Unit so that the USB Socket side is on the front, then affix it on the LED Controller by using the Ring Fix Tape.

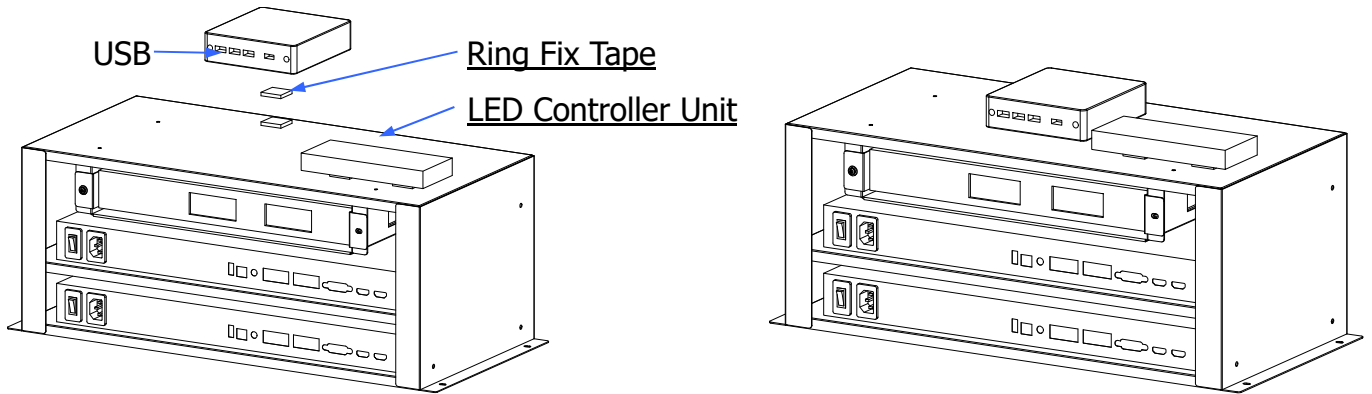

- F) Untie the Cable that is arranged around the LED Controller Unit, and connect the USB Connector to the USB 0 Port of the SMALL PC. Put the 12V AC/DC Adapter in front of the LED Controller Unit, then connect the DC Plug to the Power socket of the SMALL PC.

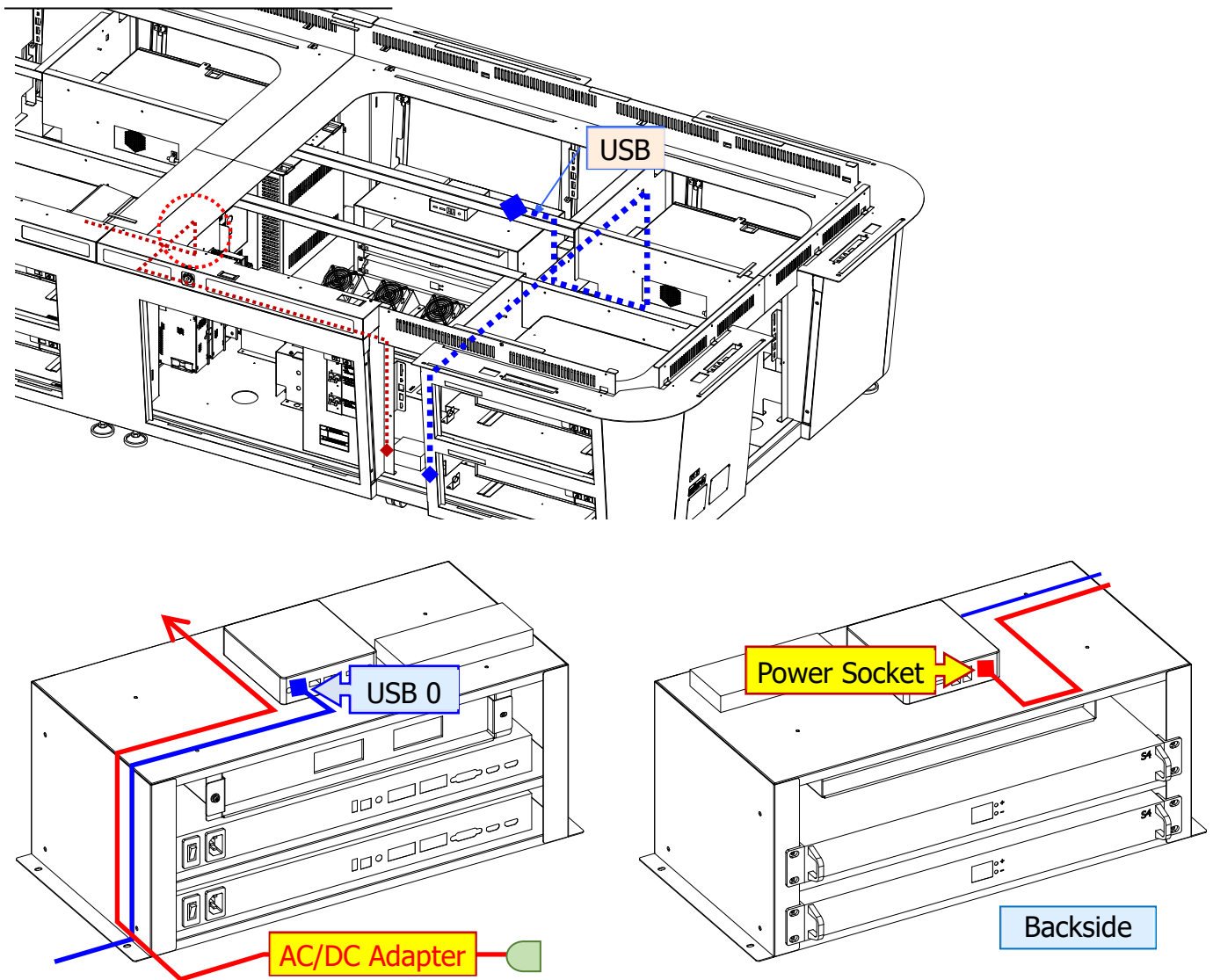

G) Prepare the following Parts.

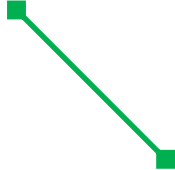
Parts Name	Qty	Appearance
Cat5e LAN CABLE 0.5m ※It may be fixed to the LED Controller Unit.	1	

H) Refer to the illustration to connect the Cat5e LAN CABLE to the Port 13 of the HUB and to the Ethernet 0 Port of the SMALL PC.

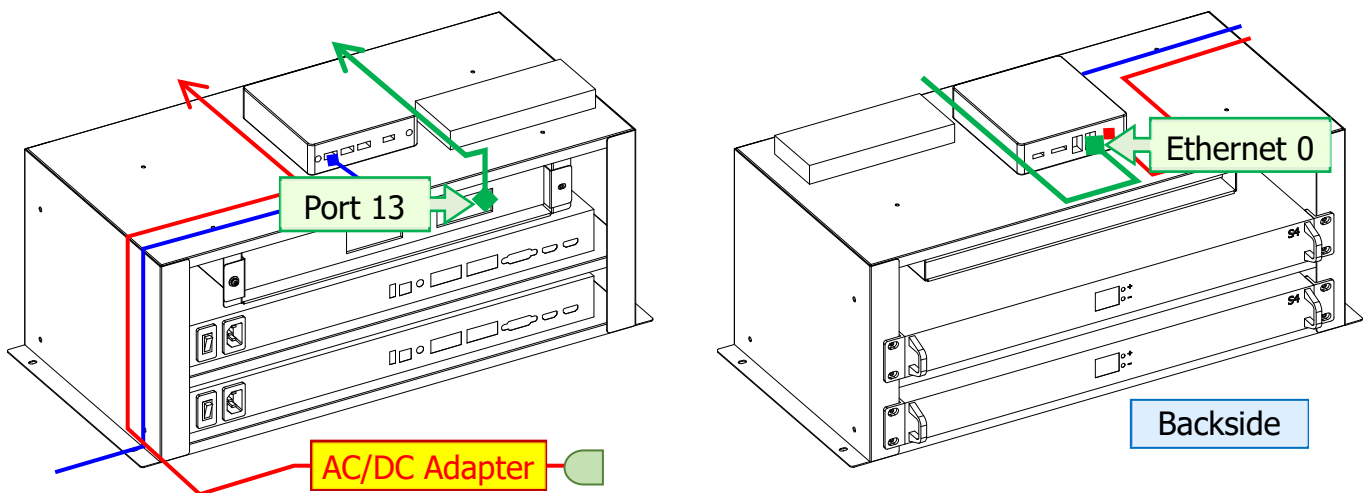

- I) Pull the AC Cable of the 12V AC/DC Adapter (for SMALL PC) through the hole indicated in the illustration below, then connect it to the power outlet previously prepared.

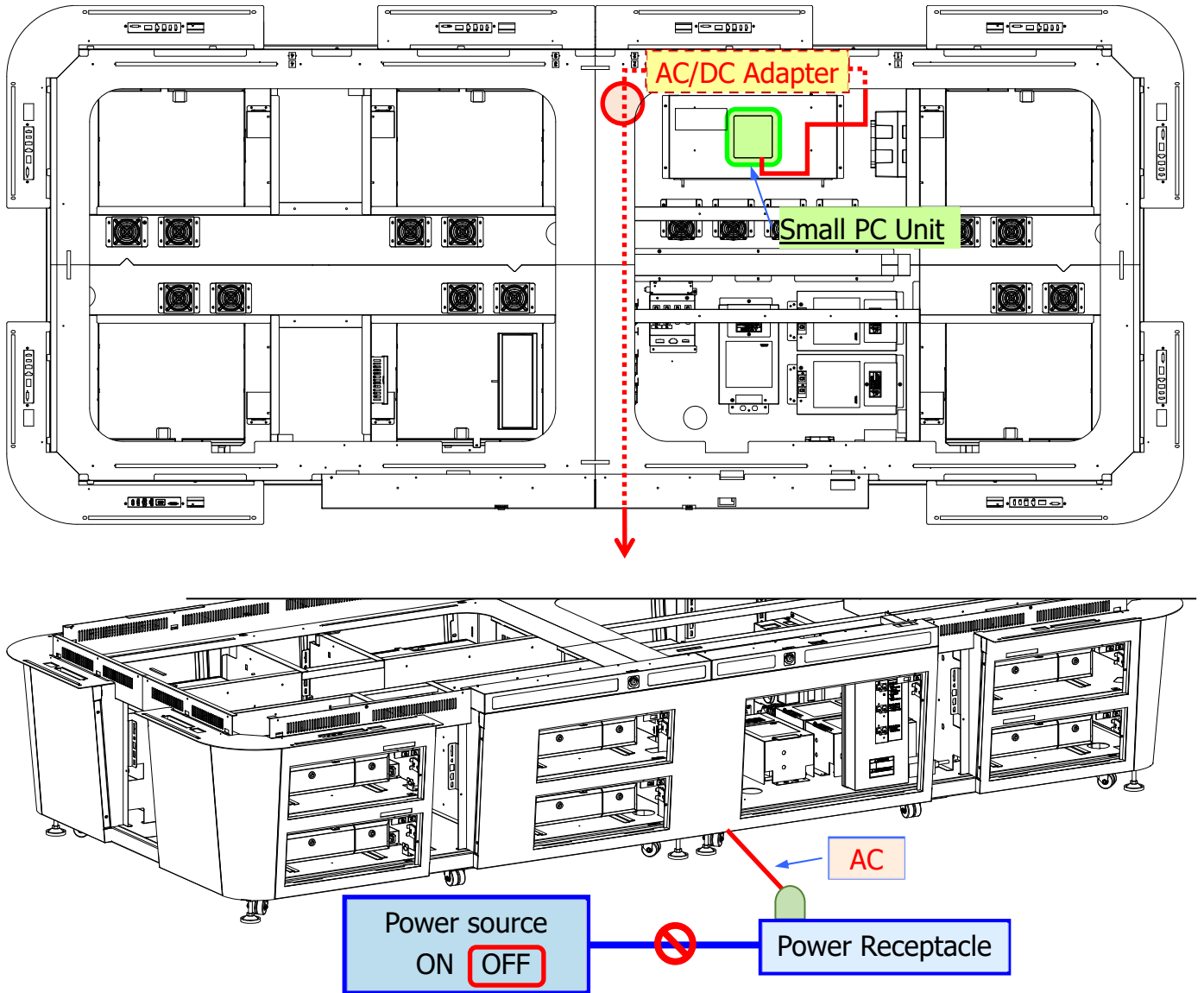

- J) Prepare the following Parts.

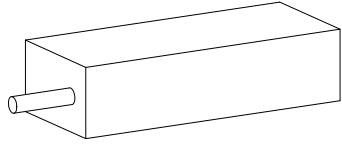
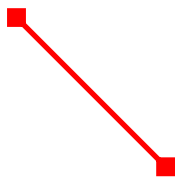
Parts Name	Qty	Appearance
24V AC/DC Adapter(for Printer) ※Included under the Part Name [PRWC PS AD HARNESS]	1	
AC Cable(for Printer)	1	

K) Put the 24V AD/DC Adapter at the back of the Switch Box of the Center Unit.

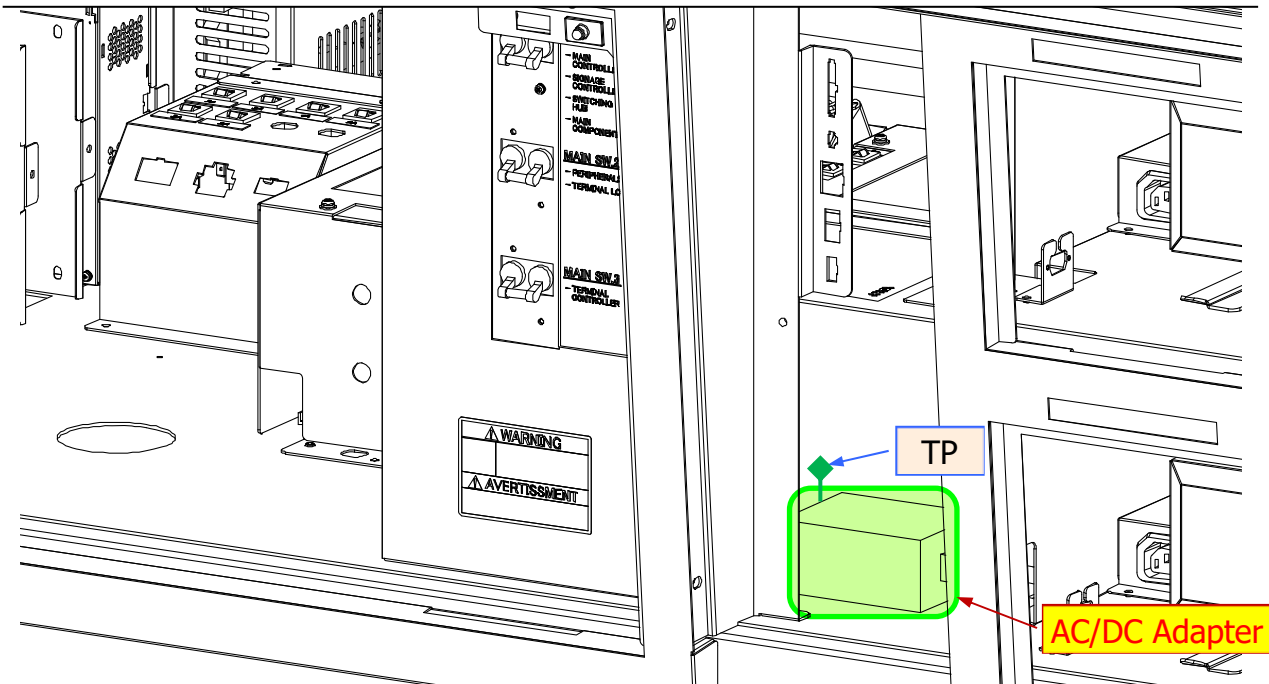

L) Locate the Tp Connector that is at the back of the Switch Box of the Center Unit, then connect it to the TP Connector of the 24V AC/DC Adapter.

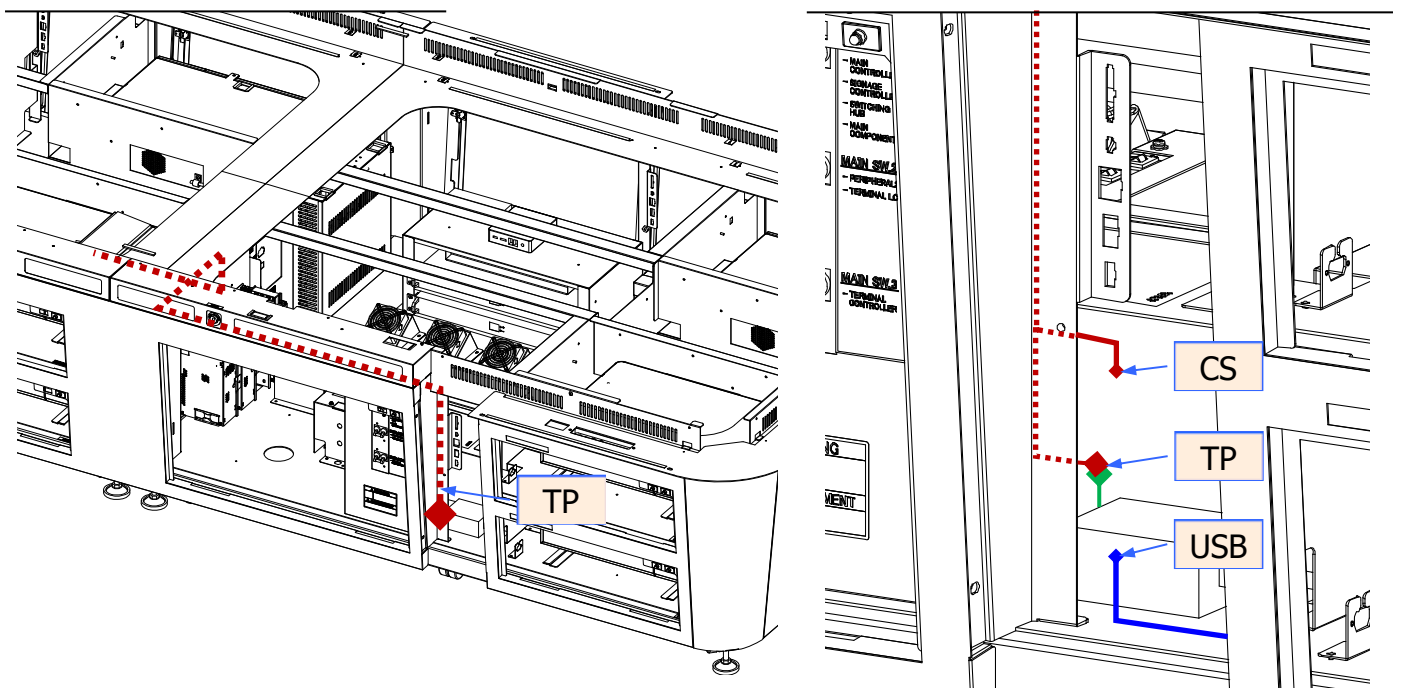

- M) Pull the AC Cable of the 24V AC/DC Adapter (for Printer) through the hole indicated in the illustration below, then connect it to the power outlet previously prepared.

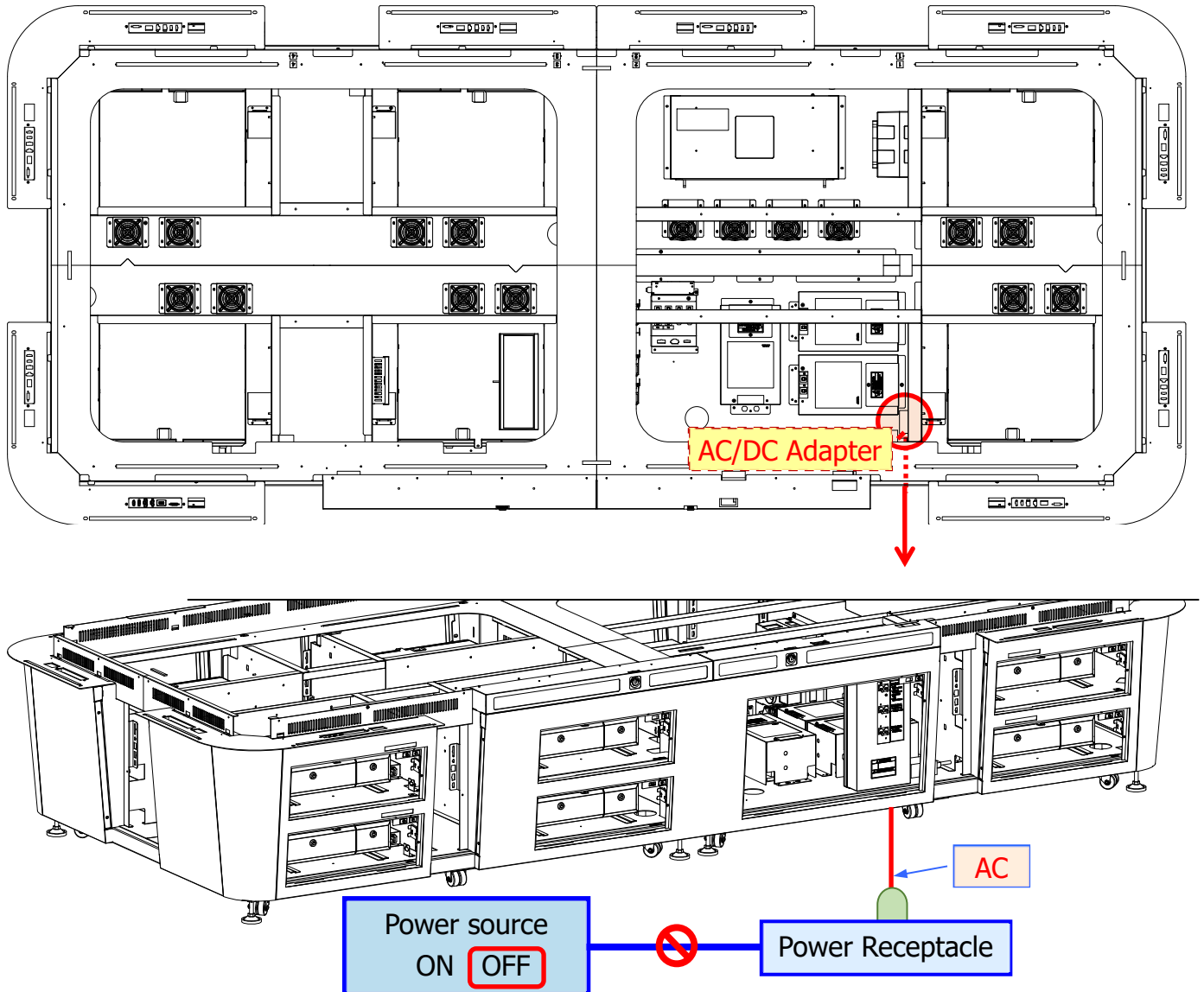

i NOTE: Option-2

At this point stop for the moment the procedure for **Option-2 - 1**; continue the common installation from **STEP 3**. The installation of **Option-2 - 2** is resumed at 3.2.10.

i NOTE: Option-6, 7

In case it was chosen the Option to install the Operation Stop Key Unit (option) or the Terminal Operation Button (Option), from this point refer to the indication **Option-6, 7**. If the Option was not chosen, continue to **STEP 3**.

Option-6, 7 - 1

- I. Locate the SVD, RL Connector that is arranged inside the Center Unit A, then untie it and pass the SVD Connector to Center Unit B.

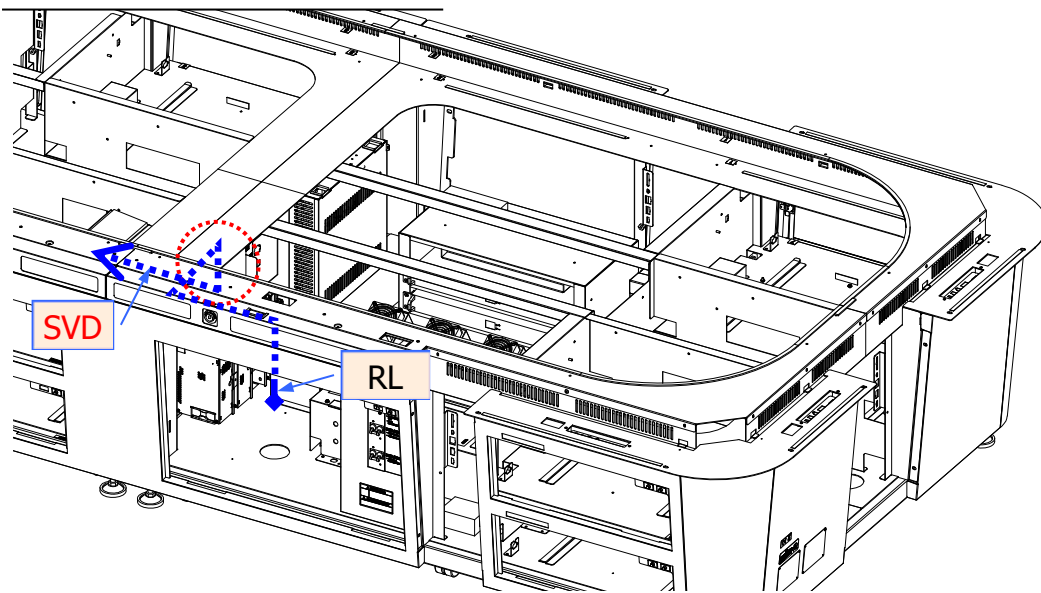

- II. Refer to the illustration below to pass the connector inside the shelf of the Main Controller Unit. Leave the RL Connector at the opposite side inside the Center Unit A.

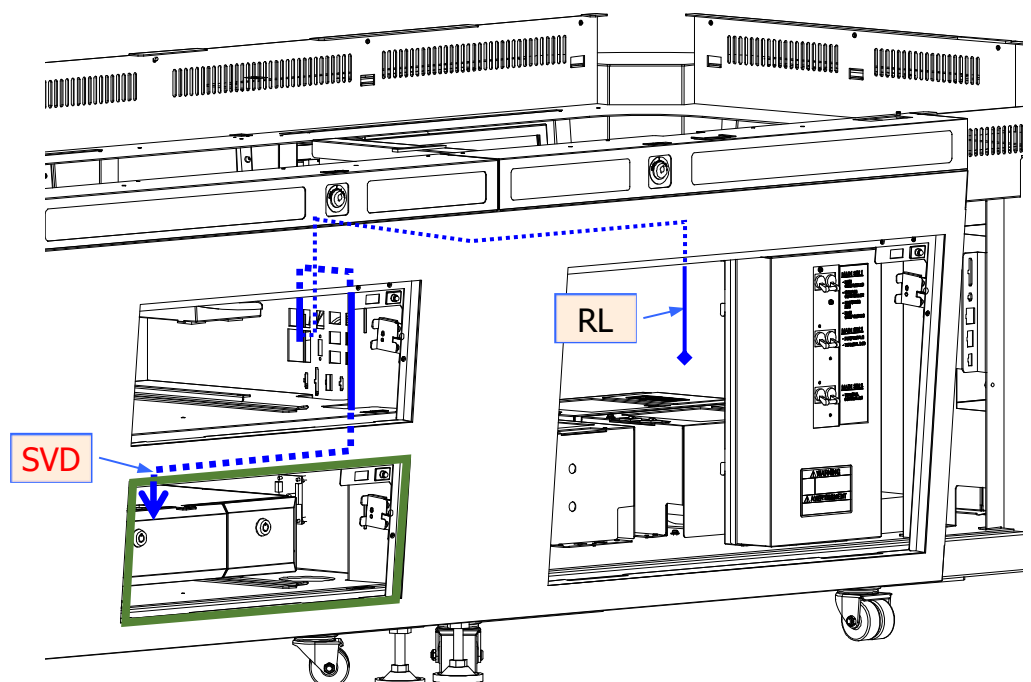

- III. Refer to the illustration below to connect the SVD Connector to the SVD Connector inside the Main Controller Unit, then close the Main Door.

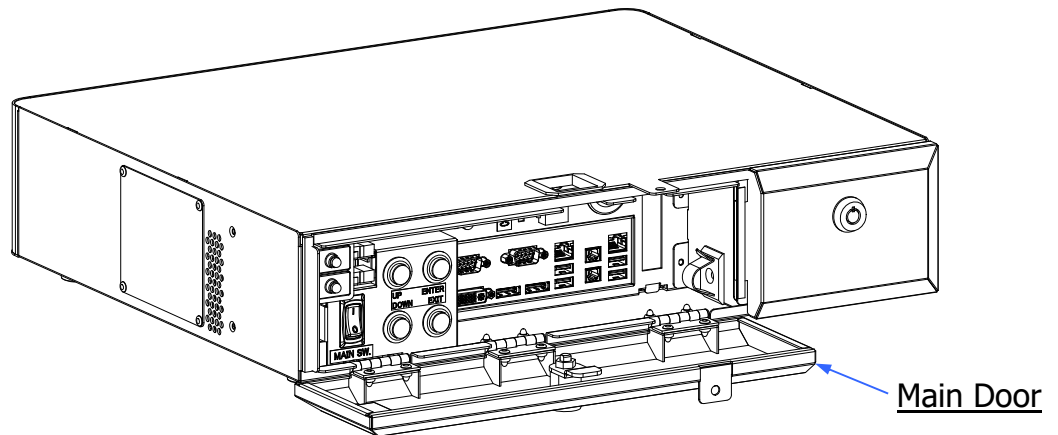
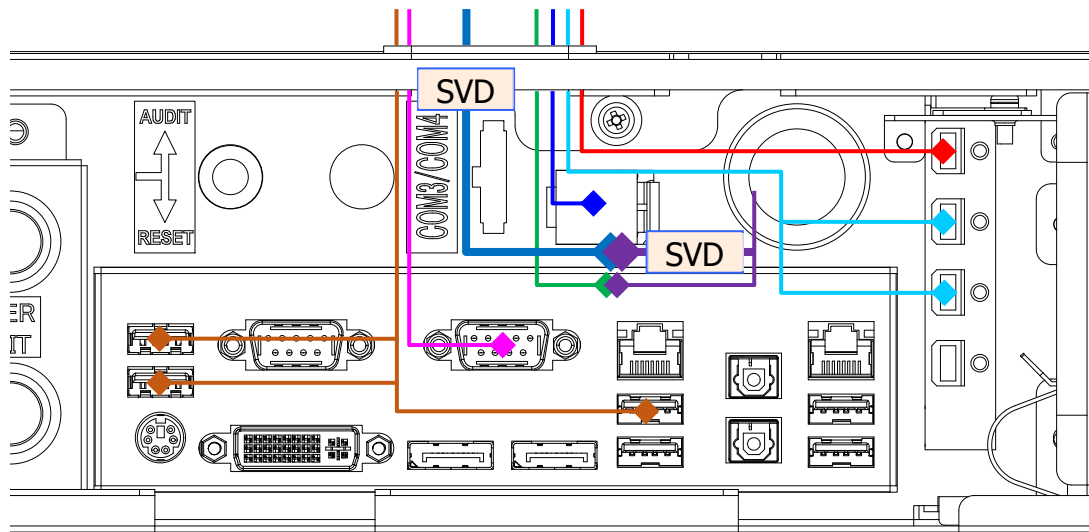

i NOTE: Option-6, 7

This completes the procedure for **Option-5, 6 - 1**; continue the common installation from **STEP 3**. The installation of **Option-6, 7 - 2** is resumed at 3.2.8.

3. Prepare the following Parts.

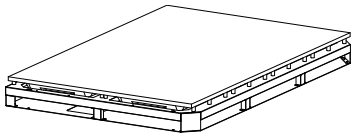
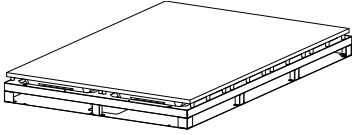
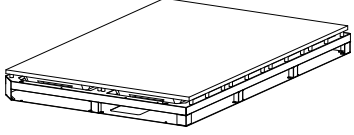
Parts Name	Qty	Appearance
Field LED Unit A (TPRC PANEL A) No.1 ※The actual appearance may differ from the illustration	1	
Field LED Unit B (TPRC PANEL B) No.2 and No.3 ※The actual appearance may differ from the illustration	2	
Field LED Unit C (TPRC PANEL C) No.4 ※The actual appearance may differ from the illustration	1	

**CAUTION!**

- There are two types of Field LED Unit, Type 1 and Type 2.

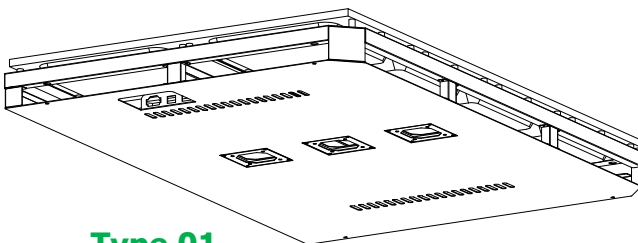
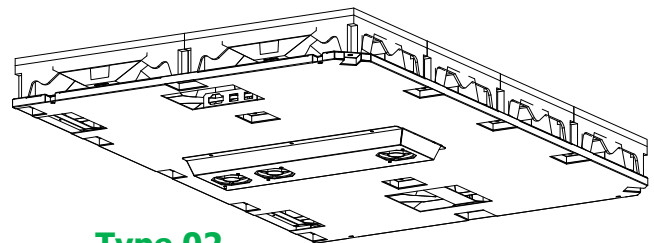
**Type 01****Type 02**

- Each Field LED Unit is composed of multiple LED Display Cabinet. During transport and installation, always hold the bottom by the Frame part behind the Field LED Unit.

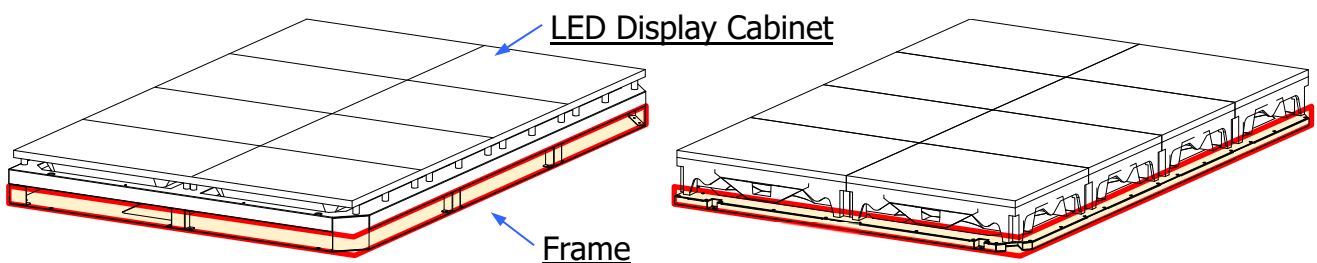

- Do not change the disposition or direction of the LED Display Cabinets.
- In case a LED Display Cabinet is replaced, it is necessary to re-install the setting program. In this case, please contact the Customer Technical Support.

- Match the Number Stickers of the Center Unit with the Number Stickers of the Field LED Unit A, B and C. Then basing the installation on the conjunction line of the Center Unit A and B, place the Field LED Unit not leaving any gap open.

i NOTE:

For the installation align the end face of the Frame of the Field LED Unit B with the junction line of Center Unit A and B.

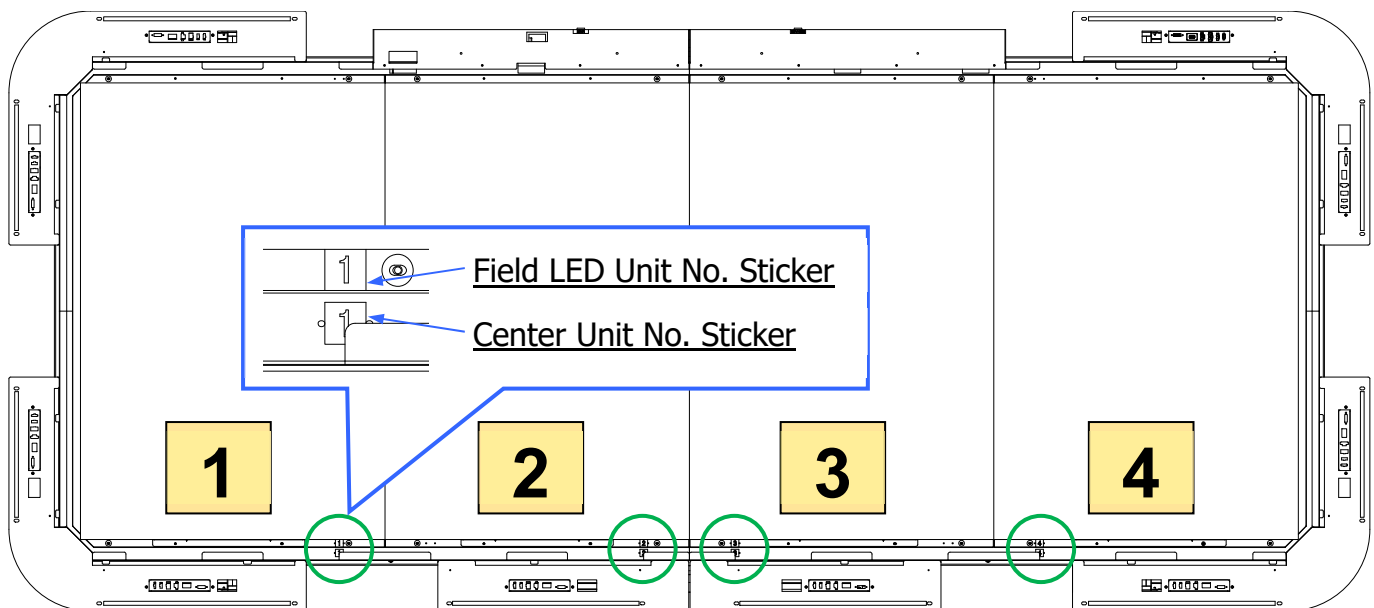
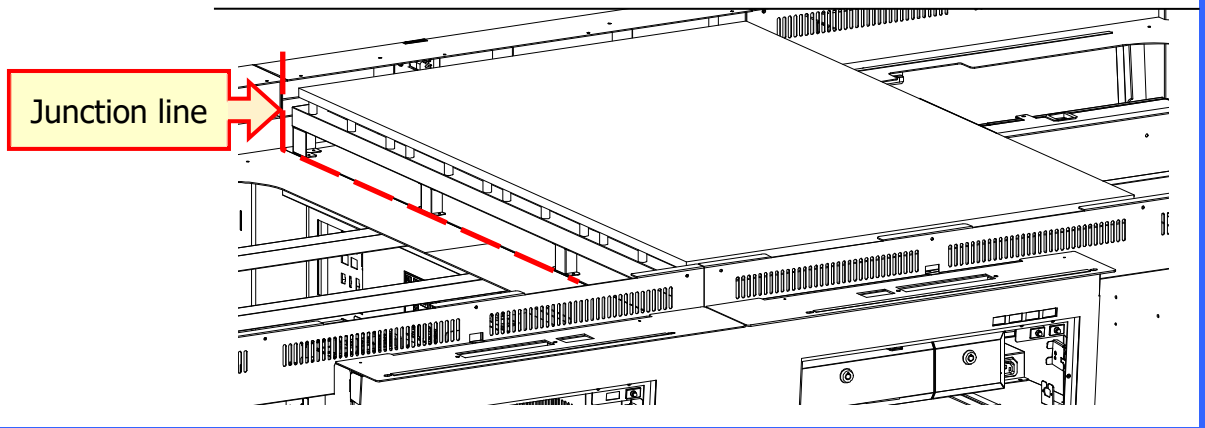

5. Affix the Field LED Units by using 4 screws on each.

Fasteners		Qty	Appearance
E	PAN M4X6 3P	16	

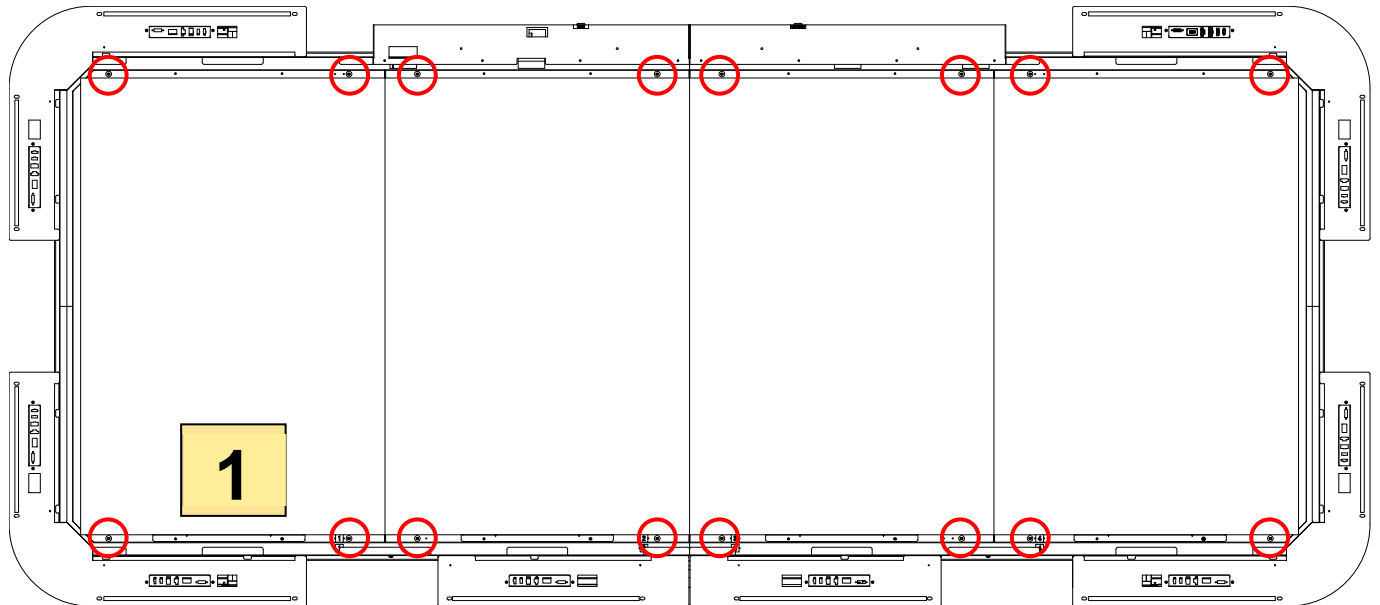

6. Untie the FD(x4) and LAN(x4) Connectors that are arranged in the 4 places indicated below, on the side of the Switch Box of the Center Unit, and then connect each of them to the Connectors of the Field LED Unit No.1-4.

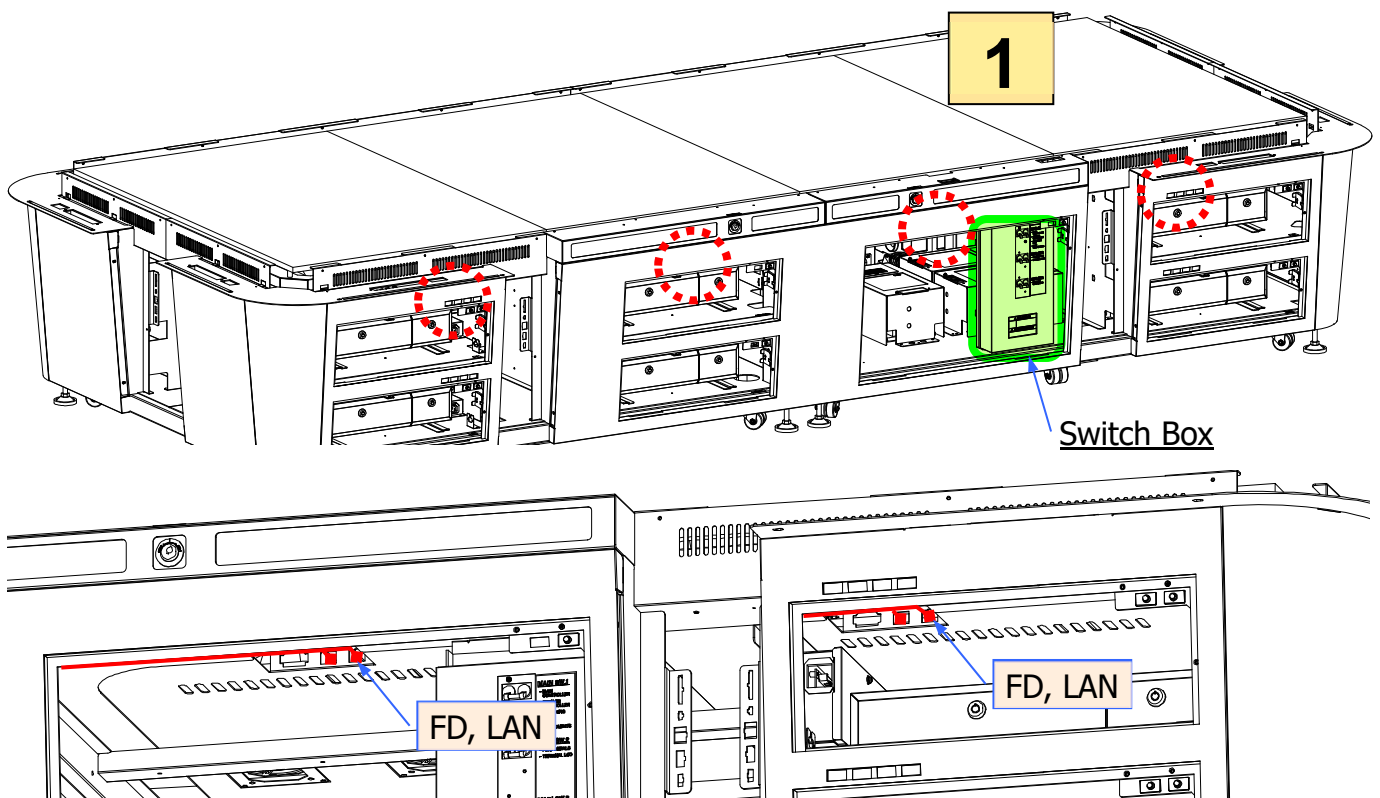

7. Prepare the following Parts.

Parts Name	Qty	Appearance
AC Cable(for Field LED Unit)	4	

8. Connect the AC Cables (for Field LED Unit) connectors of Field LED Unit 1-4. While clipping on the Clamp of the Center Unit, pull them through the hole on the bottom side and connect them to the previously prepared power supplies.

⚠ CAUTION!

The Power Switches of the Field LED Units are fixed on ON, therefore connecting their AC connectors to an electrified Power Source will boot them up. (The Controller Unit does not boot up, so no images will be displayed on the Field LED Unit) Do not electrify the Power Source.

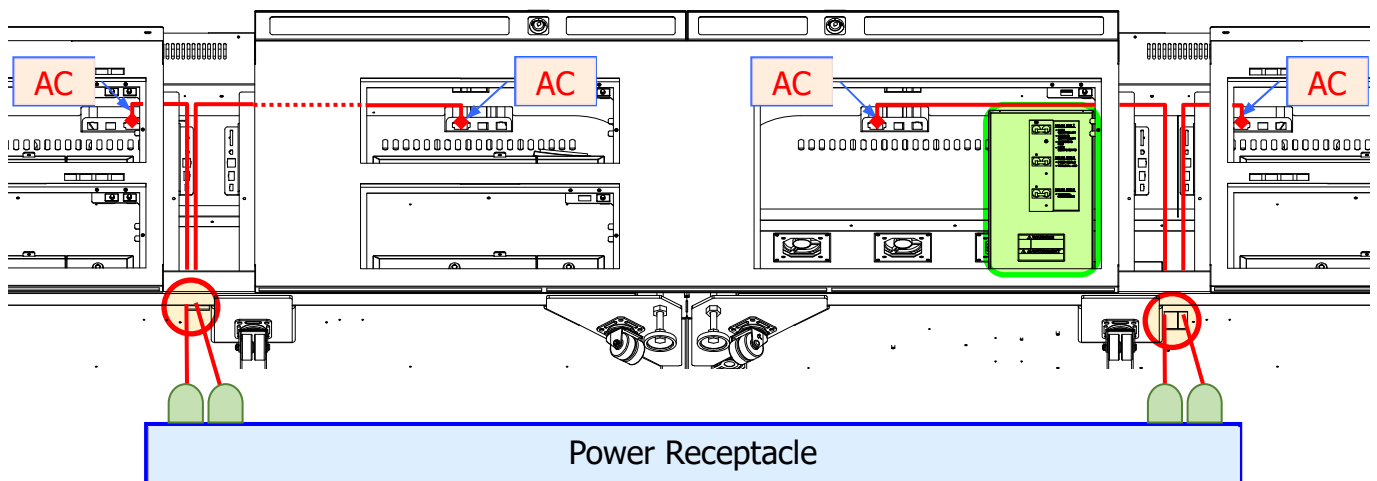
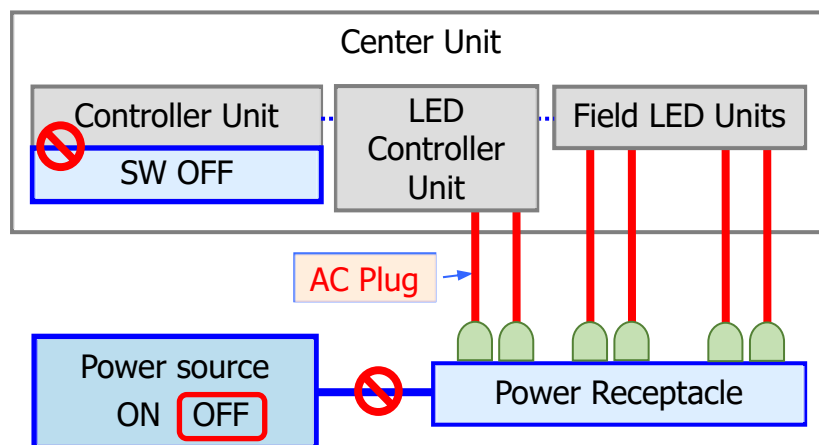

3. 2. 6: Precheck of the Field LED Unit

CALL SERVICE IMMEDIATERY!

Before proceeding with the installation, check if the images on the Field LED Unit are correctly displayed. If the images are not correctly displayed, it is necessary to re-install the setting program. Please contact the Customer Technical Support.

NOTE:

For this operation it is necessary a Notebook PC supporting a cable for HDMI port.

1. Unplug the MDP1 Cable connected to the LED Controller Unit as illustrated below, and substitute it with the HDMI Cable from the Notebook PC.

NOTE:

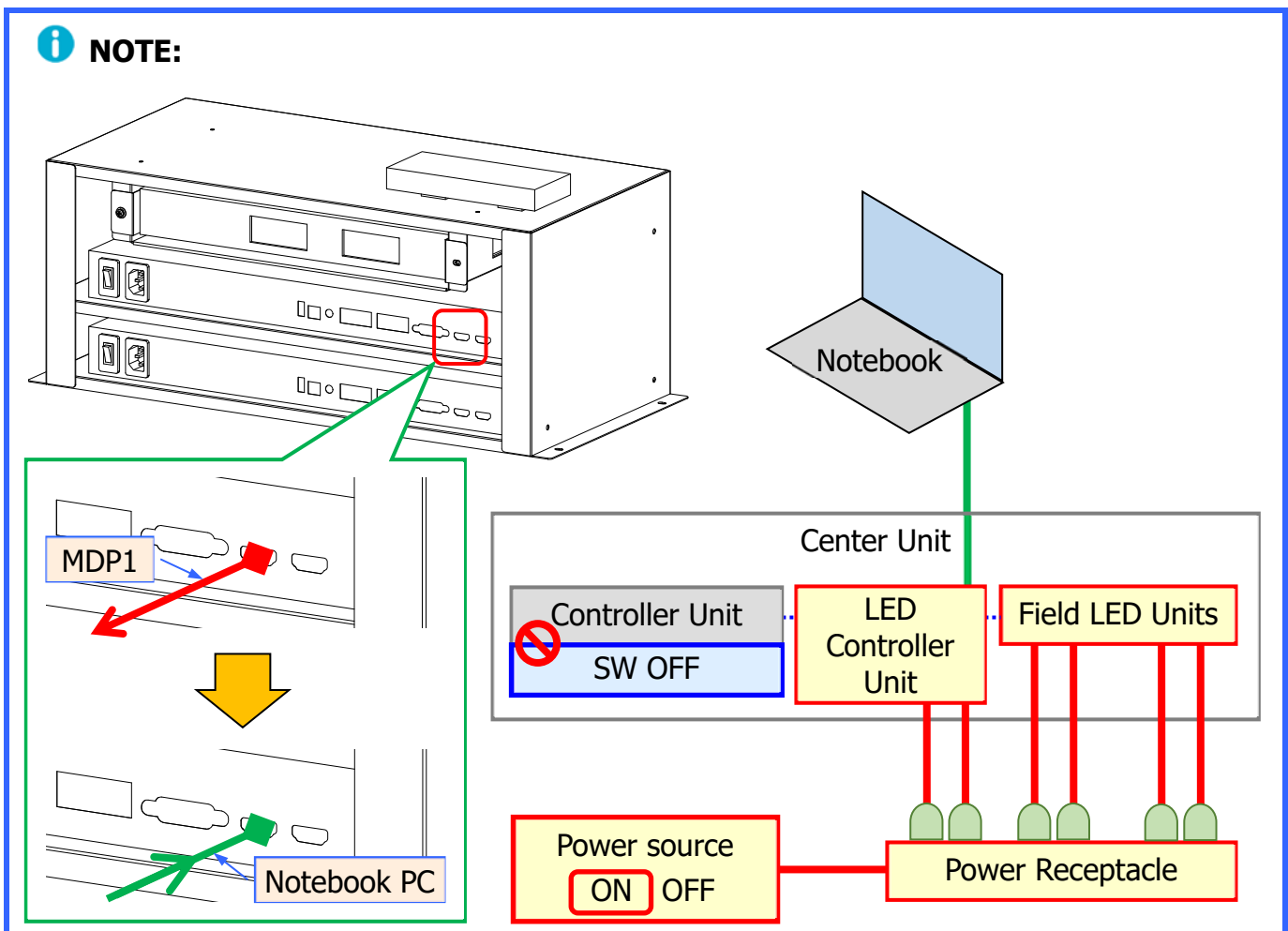

2. First turn ON the power source. The machines directly connected to the power source will boot up.
3. As the images are outputted from the Notebook PC, the Field LED Unit will show them, making it possible to check if the display works correctly.
4. After the check on the Field LED Unit is concluded, turn OFF the power source to turn OFF the machine. Reconnect as it was previously the MDP1 Cable disconnected at STEP 1.

3. 2. 7: Installing the Wall Unit

1. Return to their original position the LED Panel Cover A, B, C and D, which were removed at STEP 1, and then affix them with the screws.

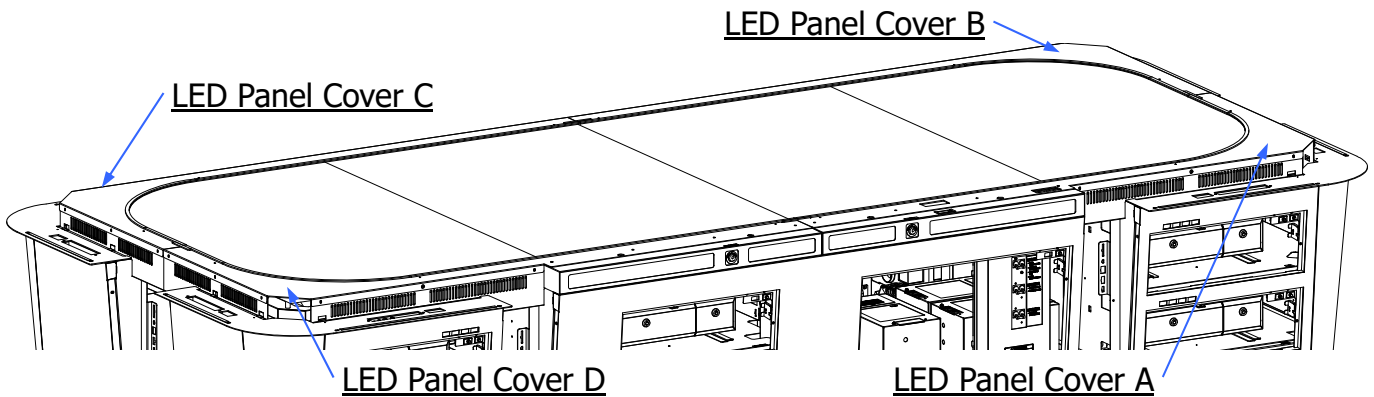

i NOTE: Option-8

If the **Option: Field Glass with Steps** was chosen instead of the Field Bumps or the Field Fabric, at this point refer to the following **Option-8**. If the **Option** was not chosen, continue to **STEP 2**.

Option-8

- A) Prepare the following Parts.

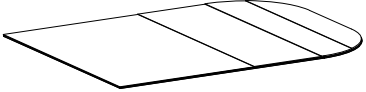
Parts Name	Qty	Appearance
Option: Field Glass	2	

- B) Align the end face of the Field Glass with the conjunction line of the Field LED Unit, and place it over the Center Unit.

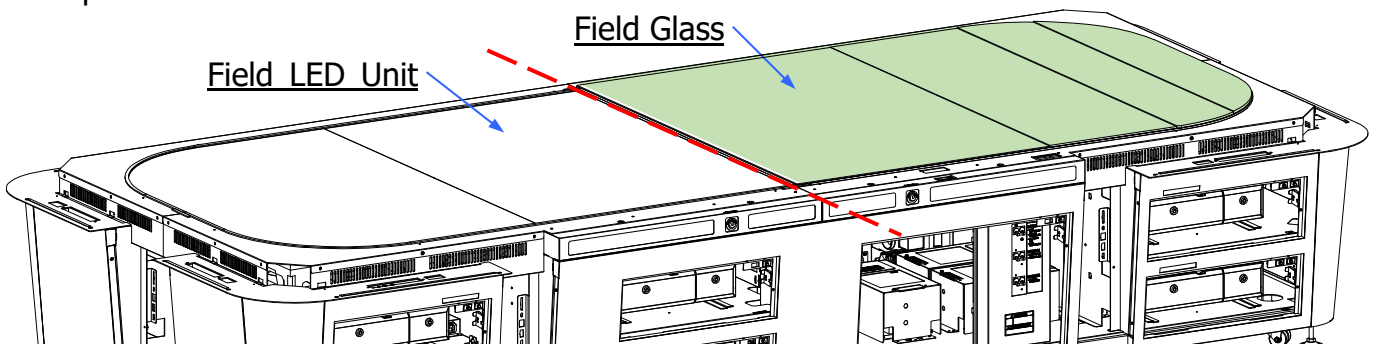

This completes the installation of **Option-8**. It is possible now to return to **STEP 6** of the general installation procedure.

2. Prepare the following Parts.

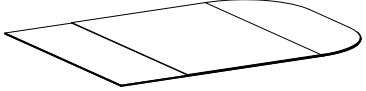
Parts Name	Qty	Appearance
Field Glass	2	

3. Align the end face of the Field Glass with the conjunction line of the Field LED Unit, and place it over the Center Unit.

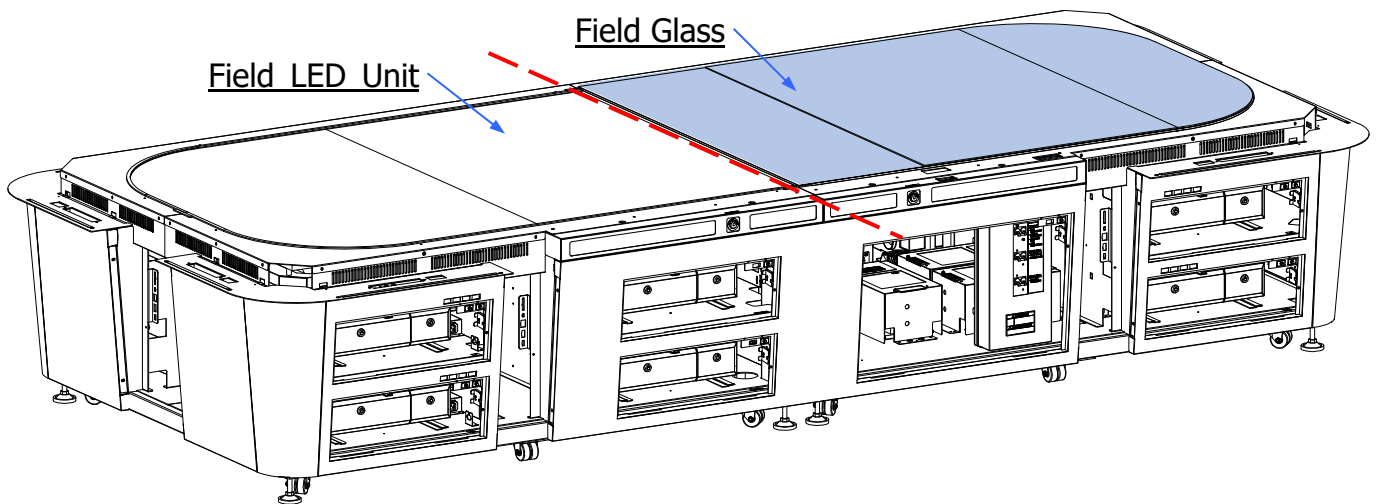

4. Prepare the following Parts.

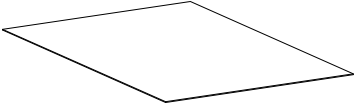
Parts Name	Qty	Appearance
URE Sheet A	1	

5. Put the URE SHEET A over the Field Glass, matching its shape.

i NOTE:

- Swipe the Glass surface before placing the URE Sheet A.
- If any bubble of air remains between the URE Sheet A and the Glass, use a squeegee or similar to push them away.

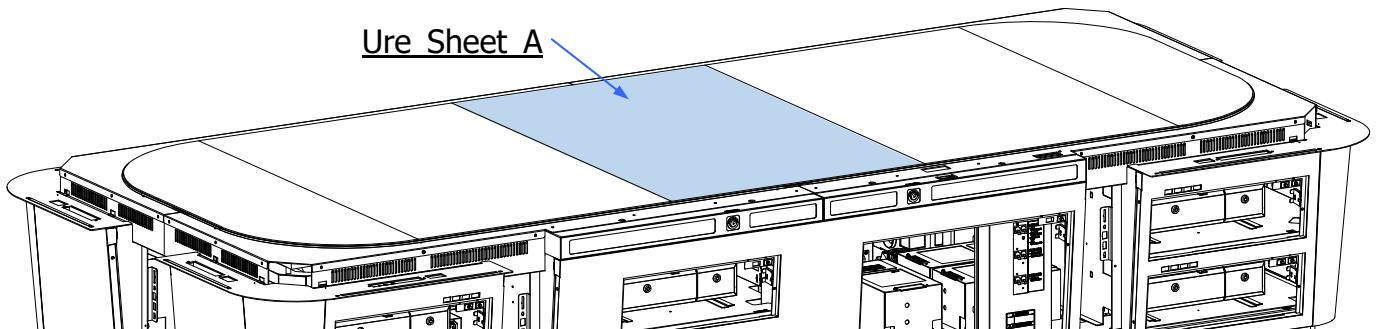

6. Prepare the following Parts.

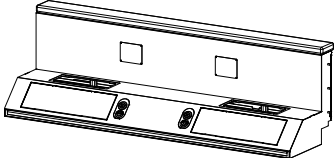
Parts Name	Qty	Appearance
Mirror Wall Unit (Wall C)	1	

7. Install the Mirror Wall Unit (Wall C) in the center of the LED Controller Unit side of the Center Unit.

⚠ CAUTION!

The Mirror Wall Unit (Wall C) is not fixed yet. Keep holding with your hands the Mirror Wall Unit (Wall C), from the start of the procedure until it is completely fixed.

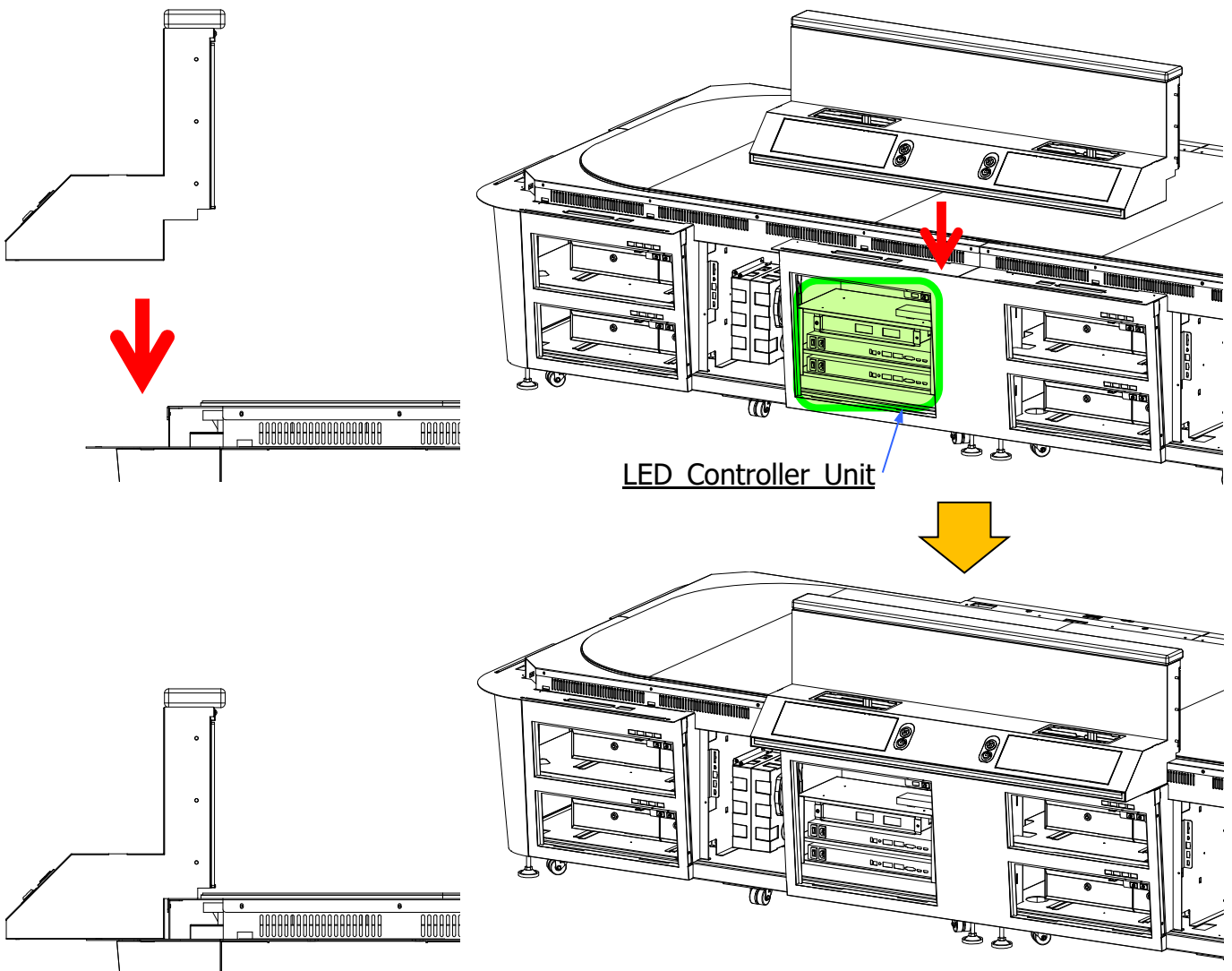

8. Fasten temporarily the Mirror Wall Unit (Wall C) to the Center Unit by using 4 screws.

Fasteners		Qty	Appearance
Db	TRUSS M5x10 BLK	4	

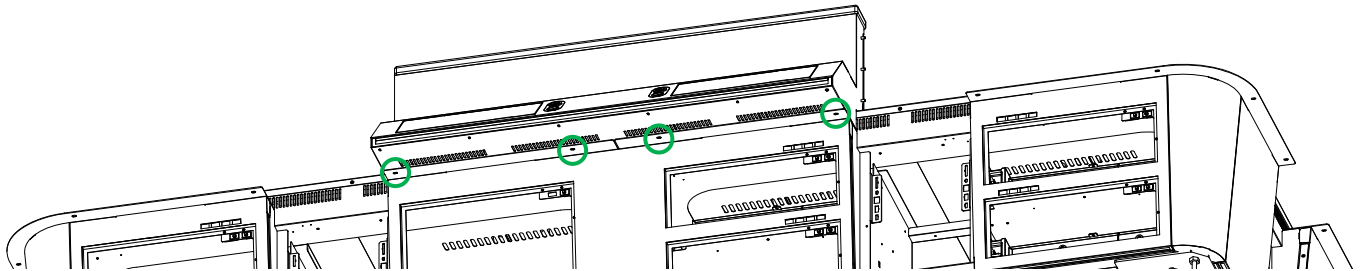

9. Prepare the following Parts.

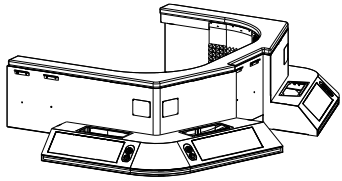
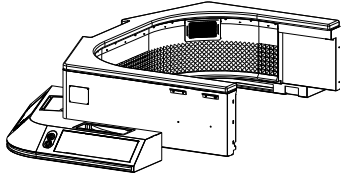
Parts Name	Qty	Appearance
Side Wall Right Unit (Wall R)	1	
Side Wall Left Unit (Wall L)	1	

10. Place the Side Wall Right Unit (Wall R) and the Side Wall Left Unit (Wall L) on each side of the Mirror Wall Unit (Wall C), and affix them with 3 nuts for each.

Fasteners		Qty	Appearance
T	FLANGE NUT M6	6	

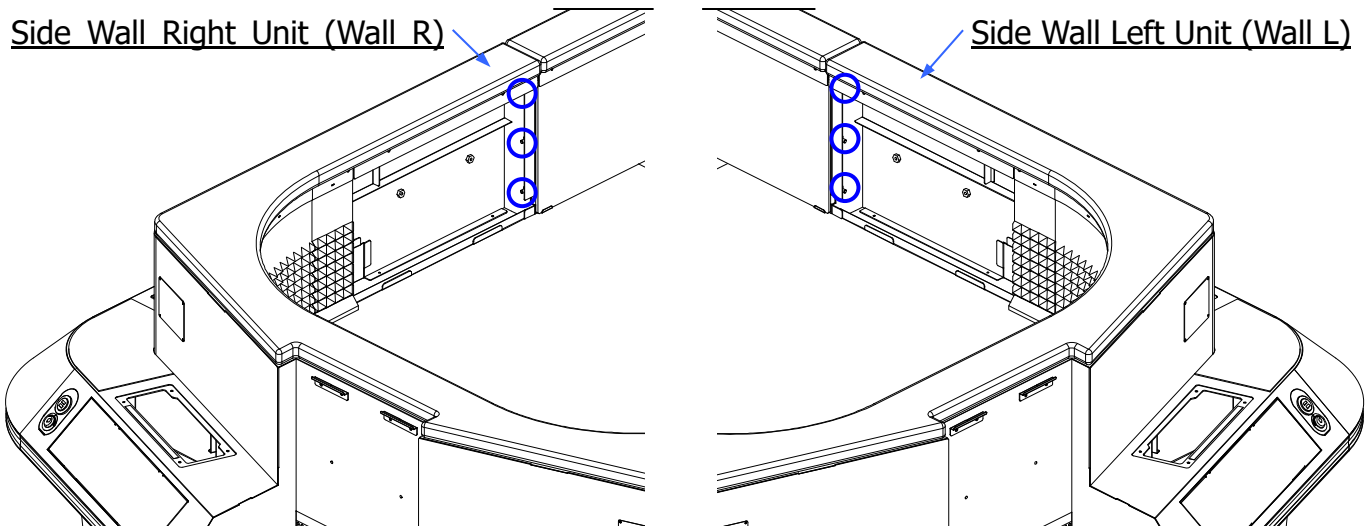

⚠ CAUTION!

The Side Wall Right Unit (Wall R) and the Side Wall Left Unit (Wall L) are not completely fixed yet. Pay attention during the procedure.

11. Untie the Cable covered by the Shielding Cover that is arranged on the side of the Switch Box of the Center Unit, and pull it through the hole indicated below.

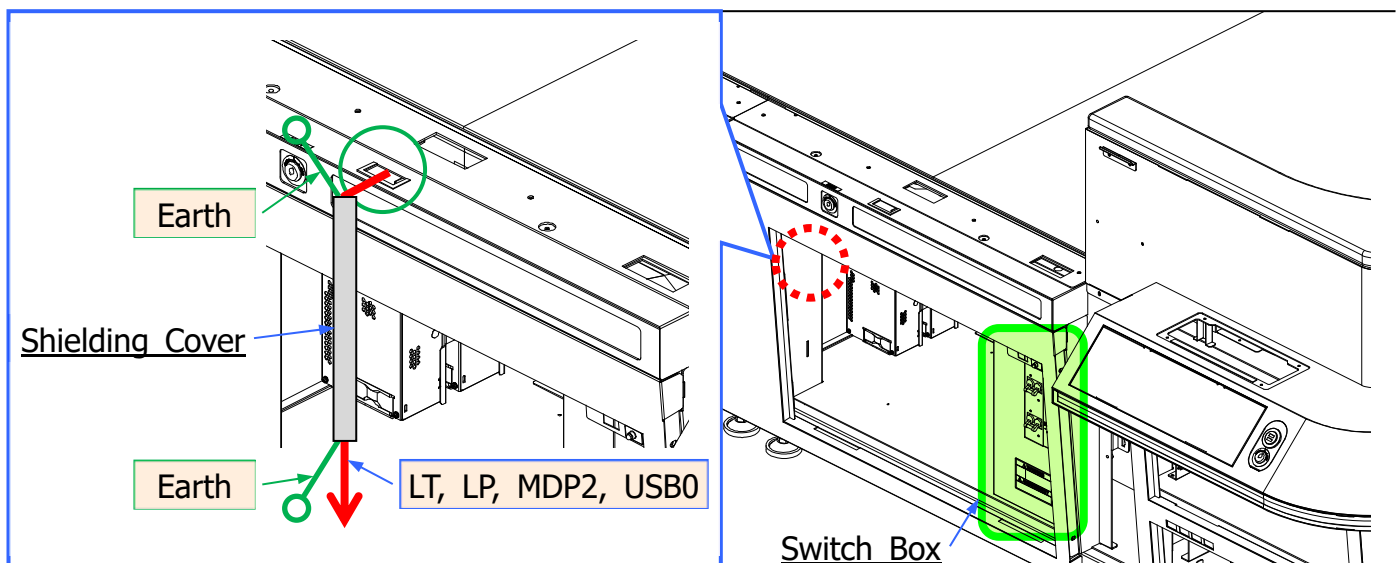

12. Prepare the following Parts.

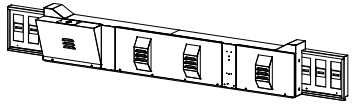
Parts Name	Qty	Appearance
Wall LED Unit	1	

13. Remove the 8 screws from the Wall LED Unit, then slide upward and detach the Wall LED Cover.

i NOTE:

- The internal PCB may differ according to different specifications, but the procedure from now on is the same.
- There are Front Fans behind the Wall LED Cover, each connected to the WF1, WF2, WF3 and WF4 Connectors. When detaching the Wall LED Cover, pay attention not to damage the connectors.

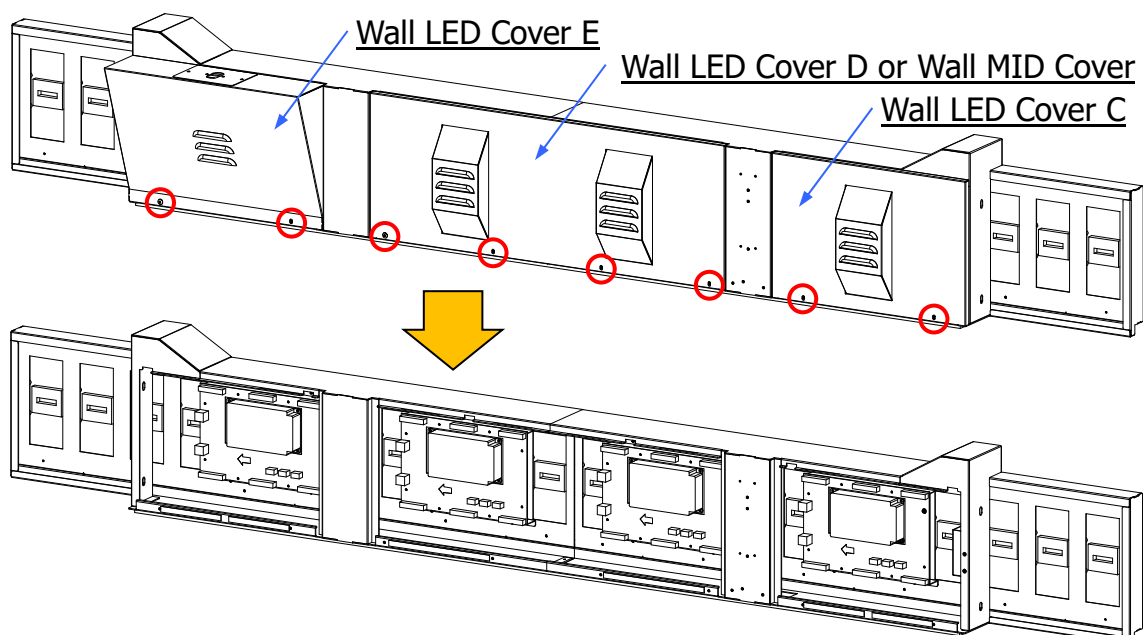
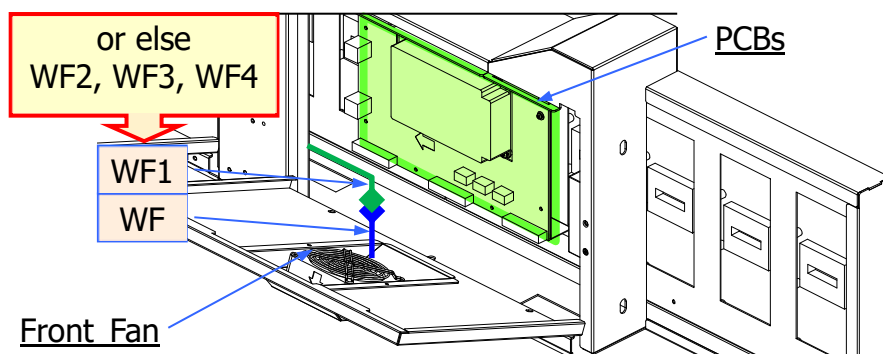

14. While paying attention not to damage the Connectors pulled out at STEP 11, insert the Wall LED Unit between the Side Wall Right Unit (Wall R) and the Side Wall Left Unit (Wall L), and affix it to the Center Unit by using 4 screws.

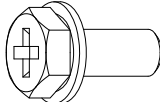
	Fasteners	Qty	Appearance
X	HEX UPSET M6 x 15 3P	4	

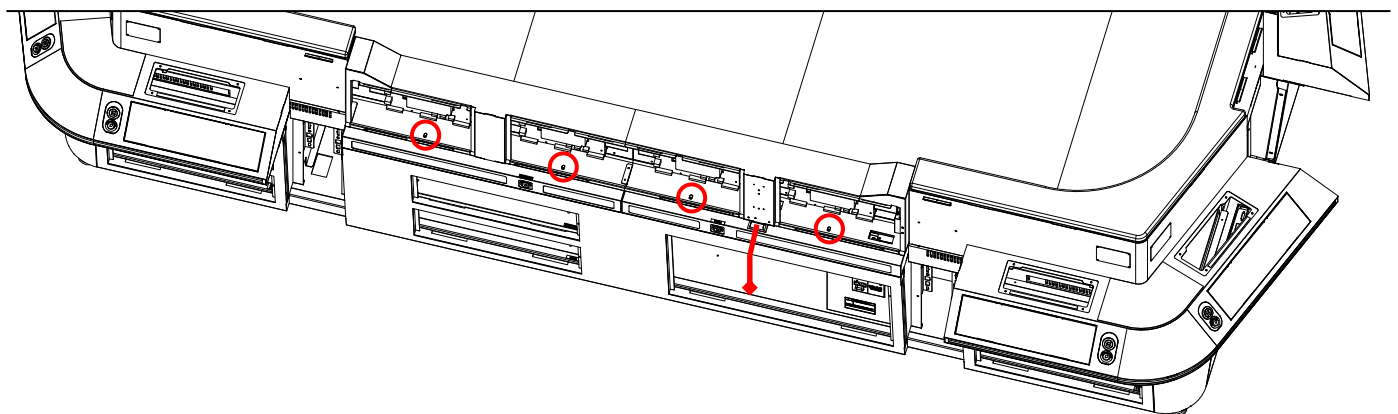
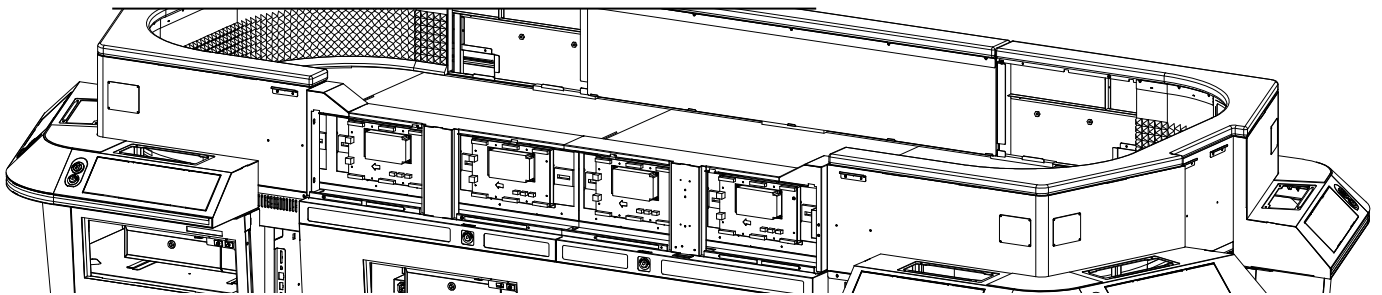
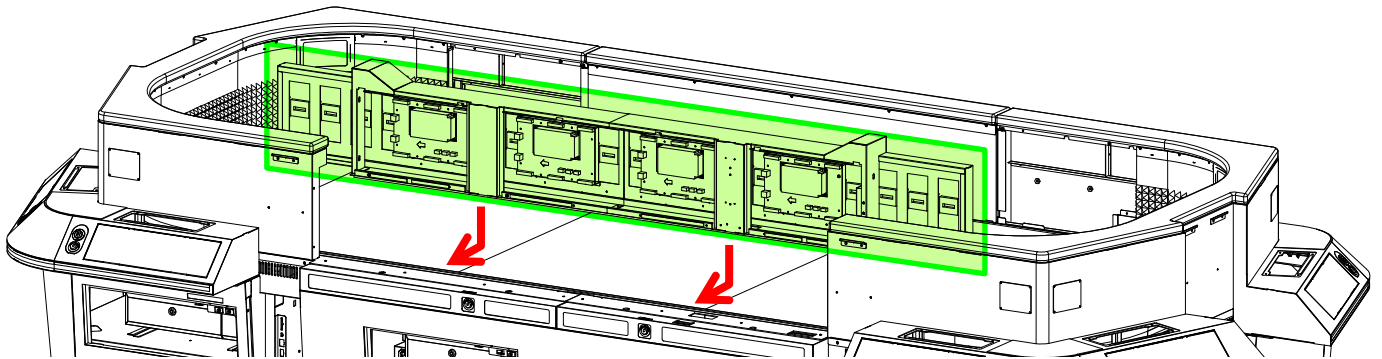

15. Affix the Side Wall Right Unit (Wall R) and the Side Wall Left Unit (Wall L) from the inner side of the Wall LED Unit, by using 2 bolts on each.

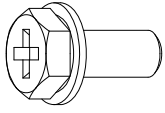
Fasteners		Qty	Appearance
X	HEX UPSET M6 x 15 3P	4	

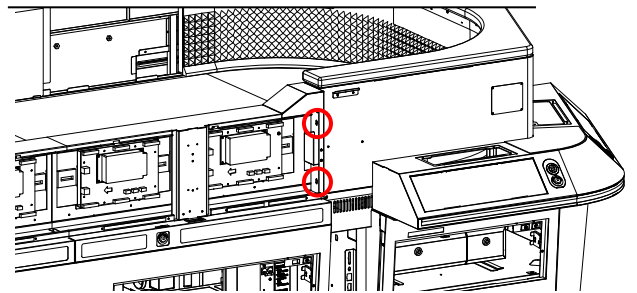
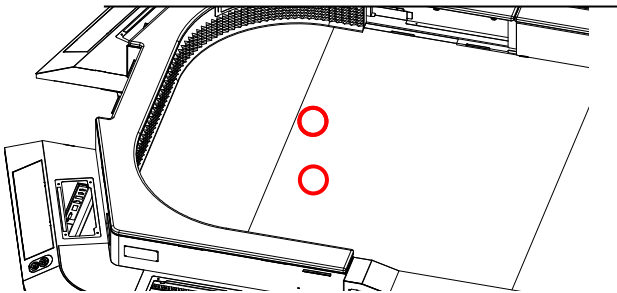

16. Affix the Side Wall Right Unit (Wall R) and the Side Wall Left Unit (Wall L) from the bottom, by using 16 screws.

Fasteners		Qty	Appearance
Db	TRUSS M5x10 BLK	16	

i NOTE:

It may be necessary to loose once the screws to adjust the parts in order to affix them.

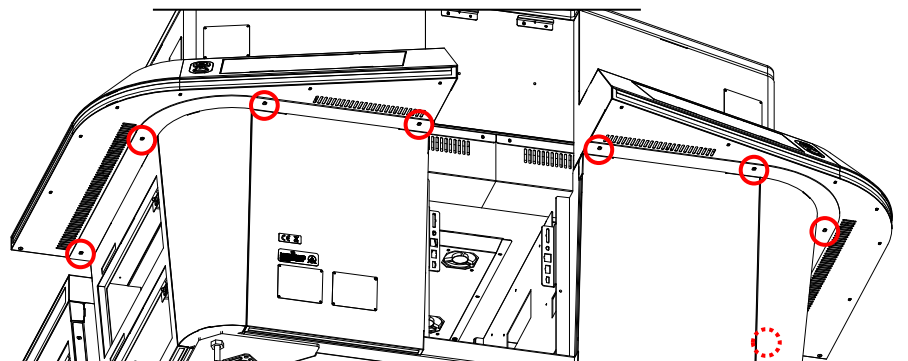
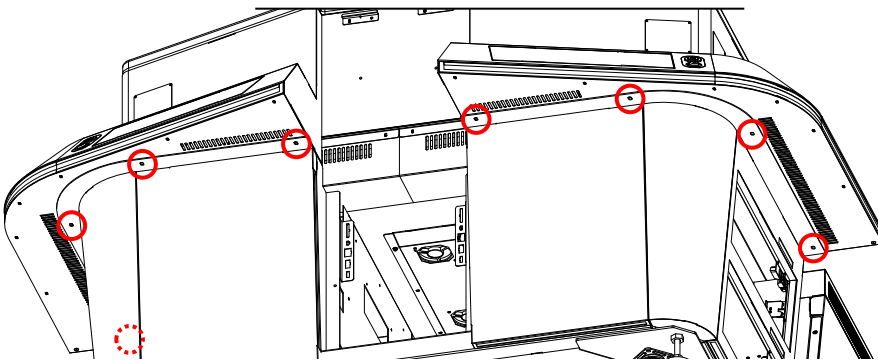

17. Affix definitively the Mirror Wall Unit that was partially affixed at STEP 8.

i NOTE:

Check that all the screws affixed in this chapter are completely and firmly fastened.

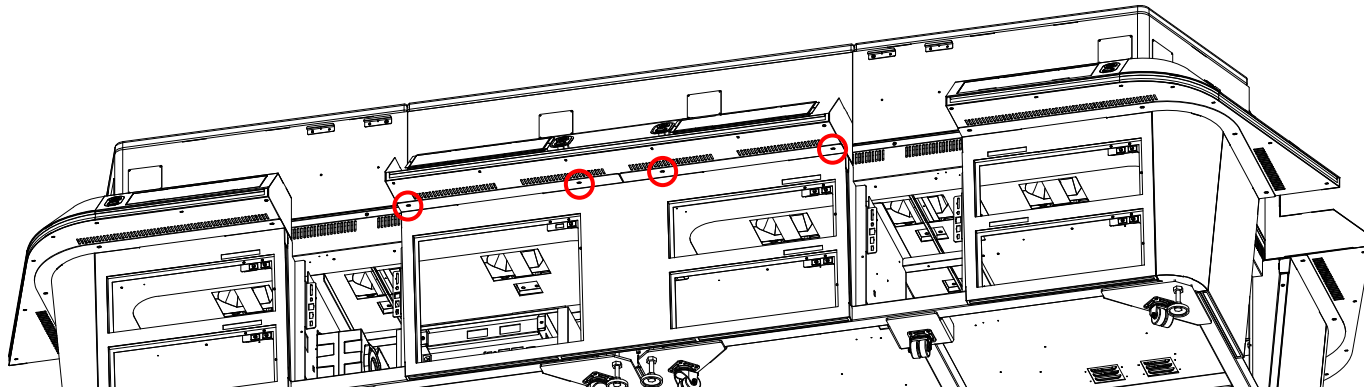

3. 2. 8: Connecting the Wall Unit

1. Untie the LM(x2) and LN(x2) Connectors that are arranged inside the Mirror Wall Unit (Wall C).

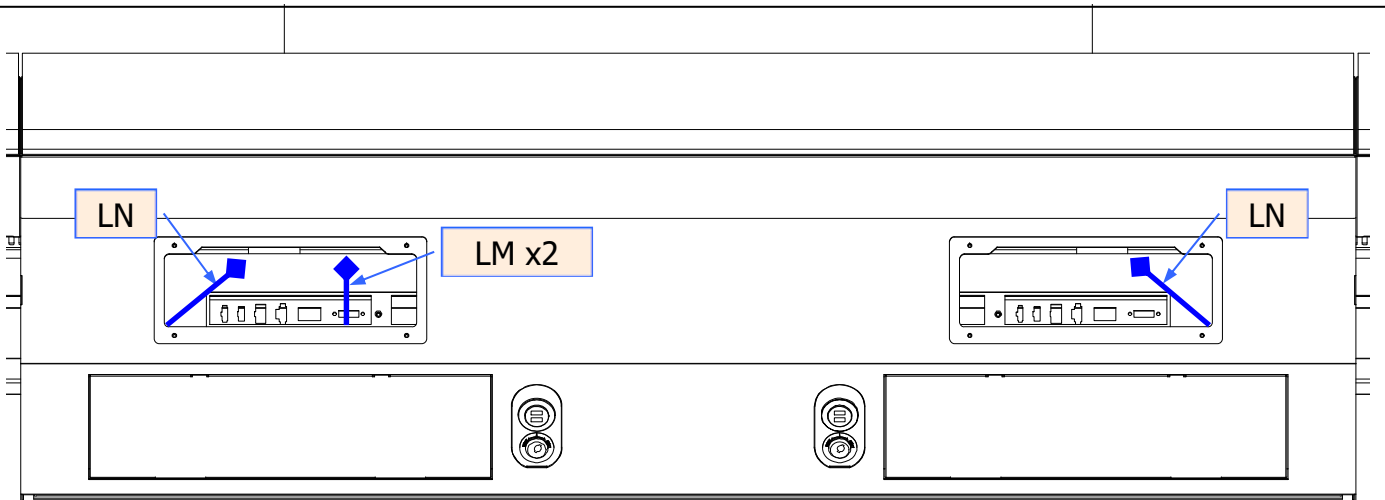

2. Untie the LM1, LM2 Connectors that are arranged at the side of the LED Controller Unit of the Center Unit.

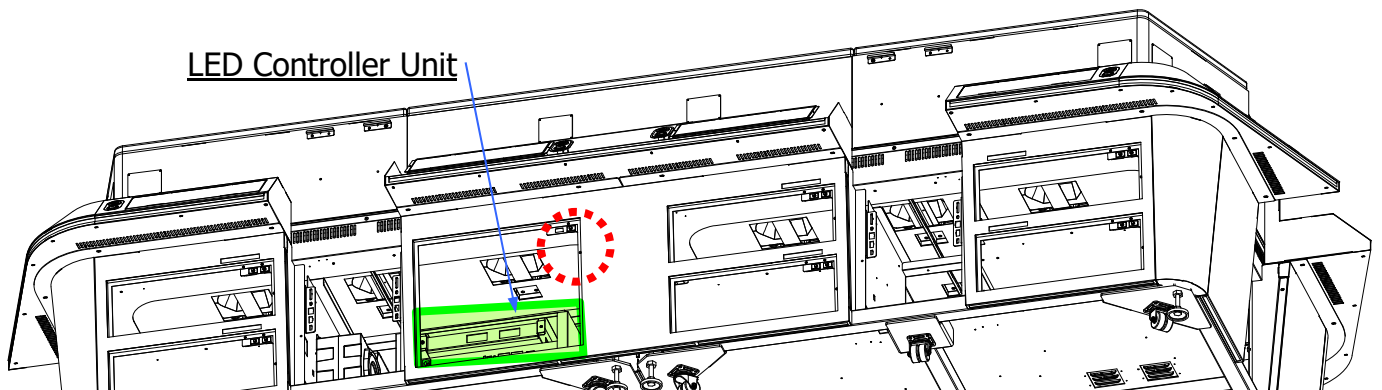

3. Insert inside the Mirror Wall Unit (Wall C) through the hole illustrated below, the LM1 and LM2 Connectors, which are described above. Then connect them to the LM (x2) Connectors of the Mirror Wall Unit (Wall C).

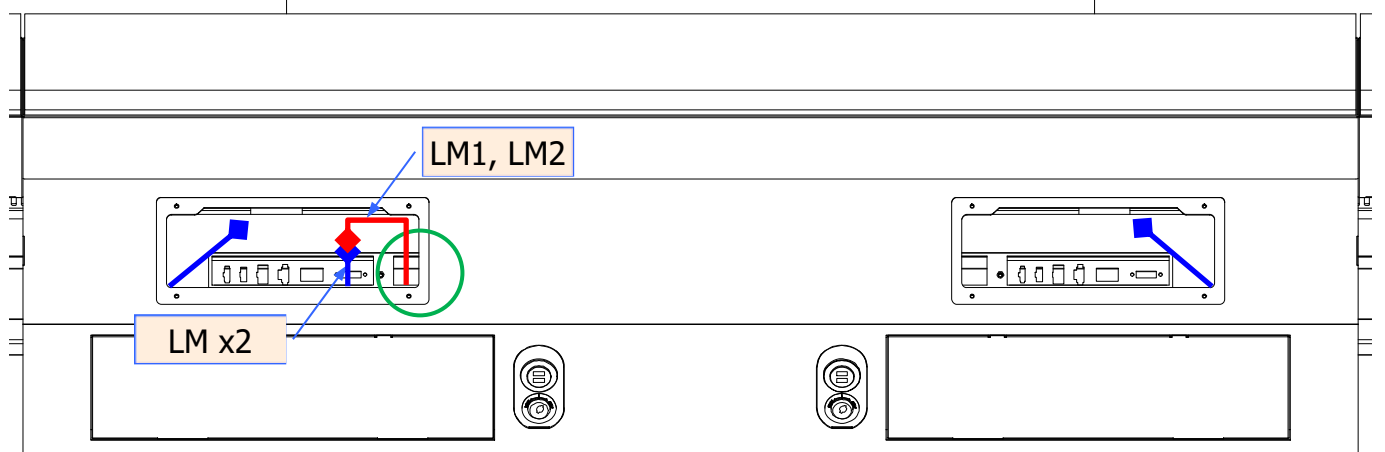

- Untie the LN Connectors kept inside the Side Wall Right Unit (Wall R) and the Side Wall Left Unit (Wall L), and then push them inside the Mirror Wall Unit (Wall C) through the hole indicated below. Then connect the LN (x2) Connectors pushed inside the unit to the LN (x2) Connectors of the Mirror Wall Unit (Wall C).

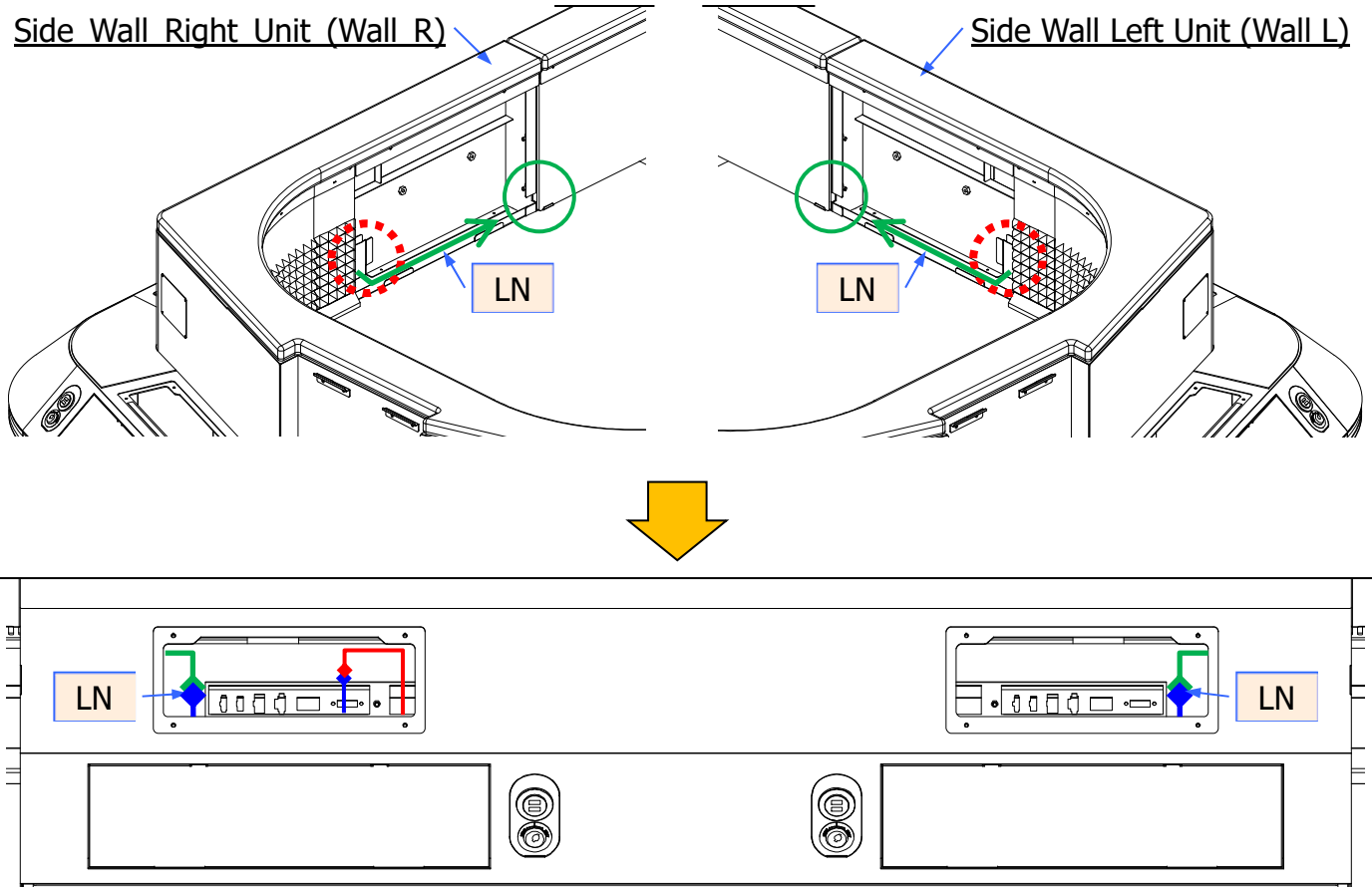

- Untie the WL, LP1 and TX Connectors, and the AC Cable arranged at the side of the Switch Box of the Center Unit, and pull them inside the Wall LED Unit through the hole illustrated below.

i NOTE: Option-1

In case the Tower Light (Option) is not installed, there is no TX Connector.

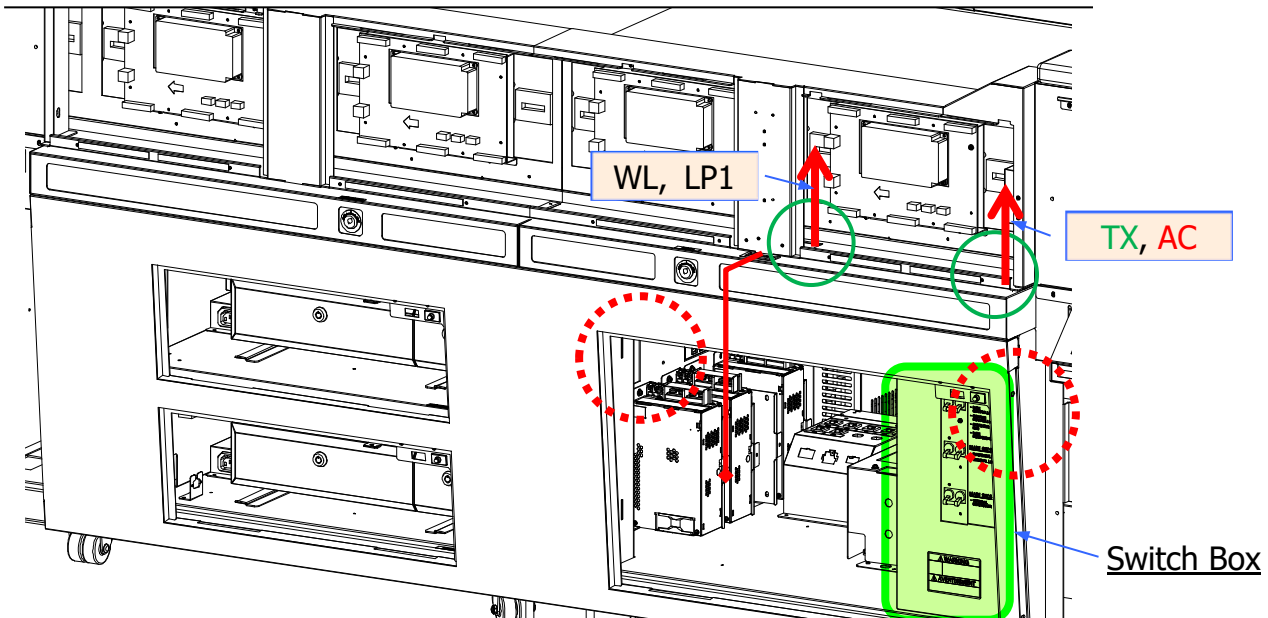

- Connect the WL, LP1, and AC pulled inside the Wall LED Unit, to the WL Connector, and also to the LAN and AC Sockets of the Wall LED Unit as indicated below. Lead the AC Plug at the opposite side of the AC Cable through the path on the Center Unit indicated below, and then pull them out of the hole in the bottom side, and connect them to the previously prepared power sockets.

i NOTE:

The position of the LAN Socket may differ according to the PCB inside the Wall LED Unit. Please refer to the illustrations below.

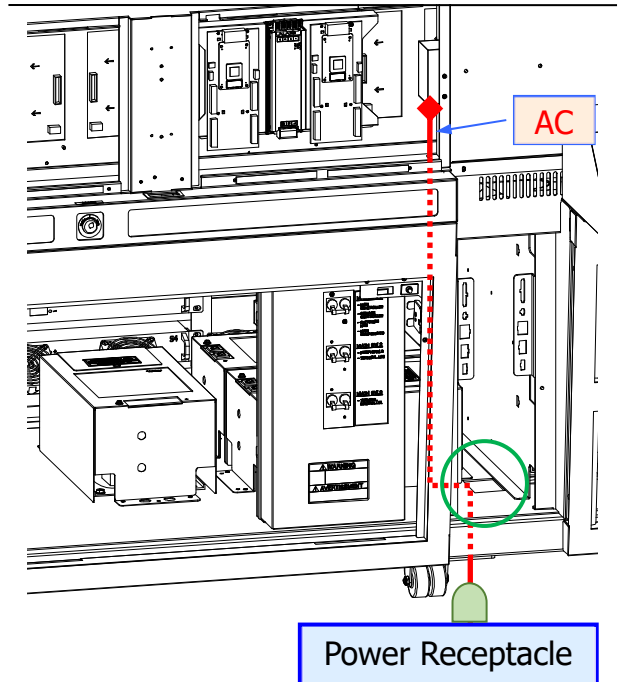
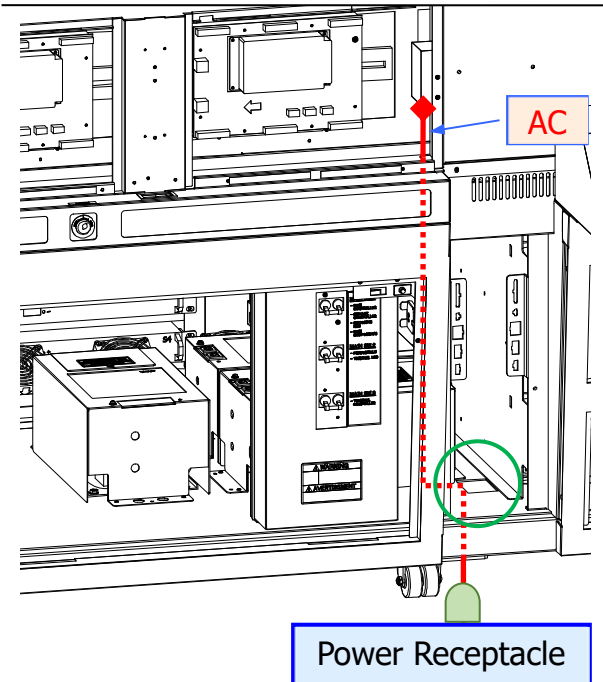
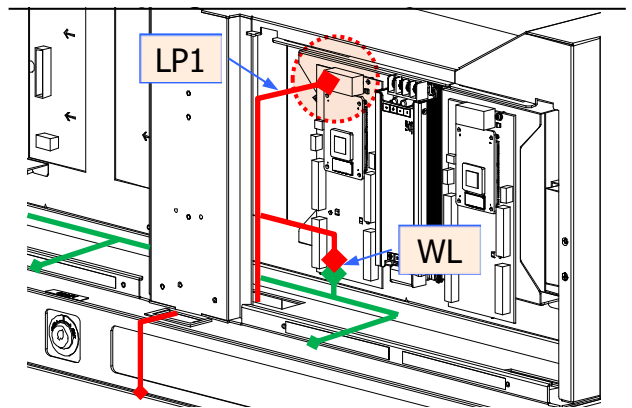
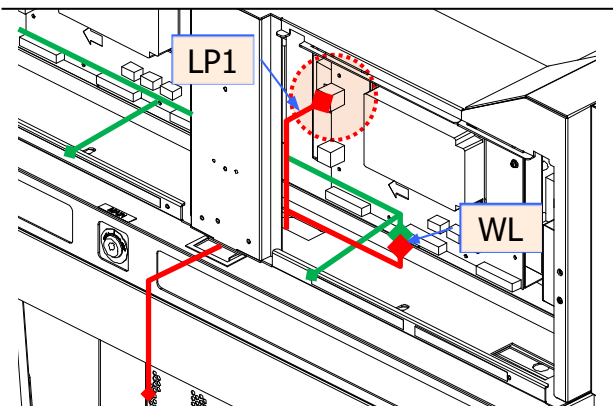

7. Refer to the illustration below to connect the TX Connector that was pulled inside the Wall LED Unit at STEP 5, to the TX Connector of the Wall LED Unit. Lead the H Connector at the opposite side through the path on the Center Unit that is illustrated below, and pull it outside the hole at the bottom.

i NOTE: Option-1

In case it was chosen as **Option-3** to install the Tower Light on the History Display Unit (Refer to 3.2.16), there is no installation of the Tower Light. Please continue from **STEP 10**.

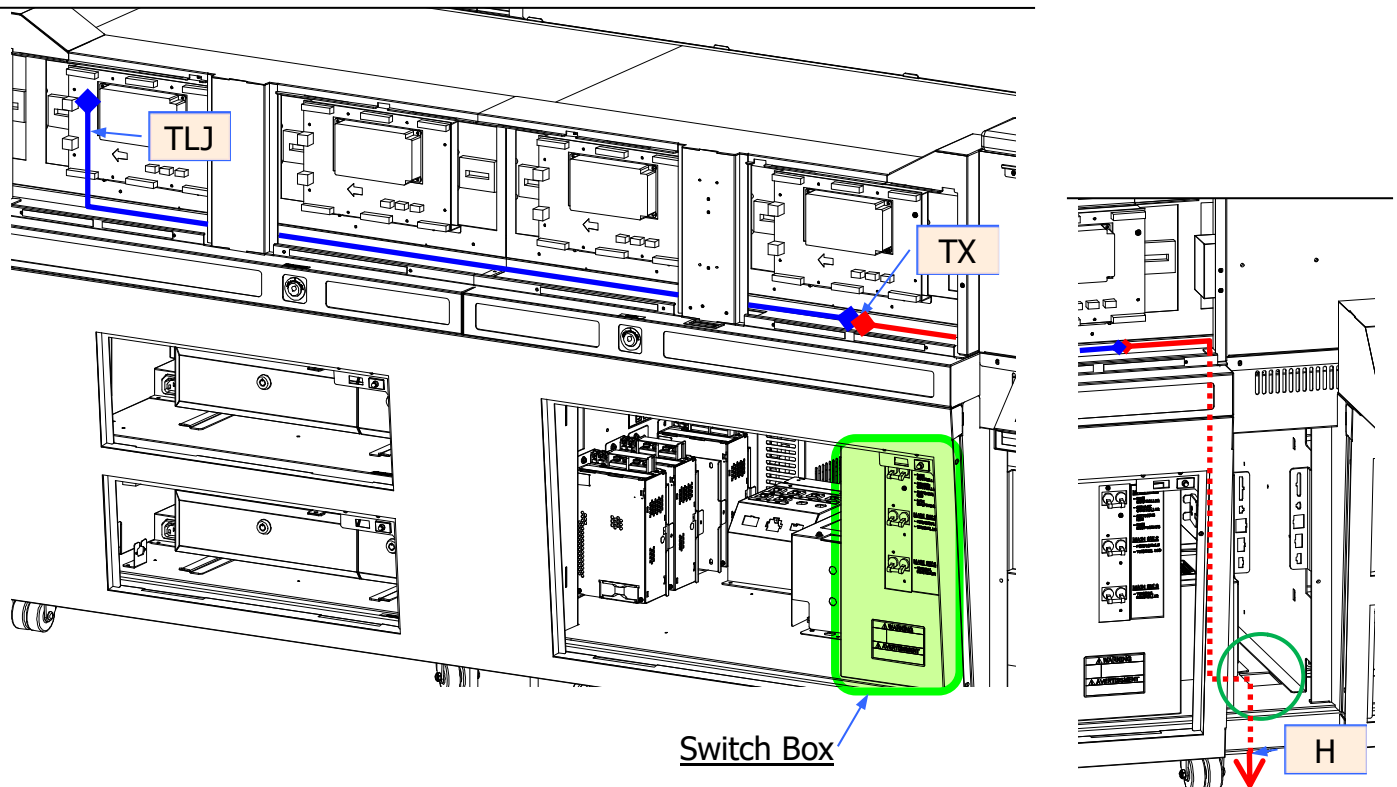

8. Thread the H Connector that was pulled from the hole, through the path indicated by the illustration while fixing it using the Clamps (on 3 places), then pull it inside the Shelf through the hole at the bottom of the Center Unit.

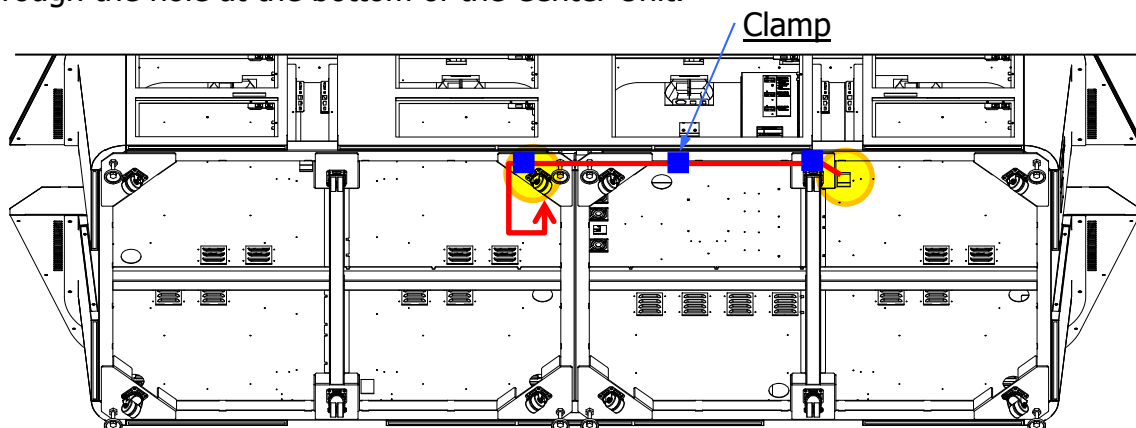

9. Locate the H Connector that is arranged inside the Shelf and connect it to the H Connector that was drawn inside.

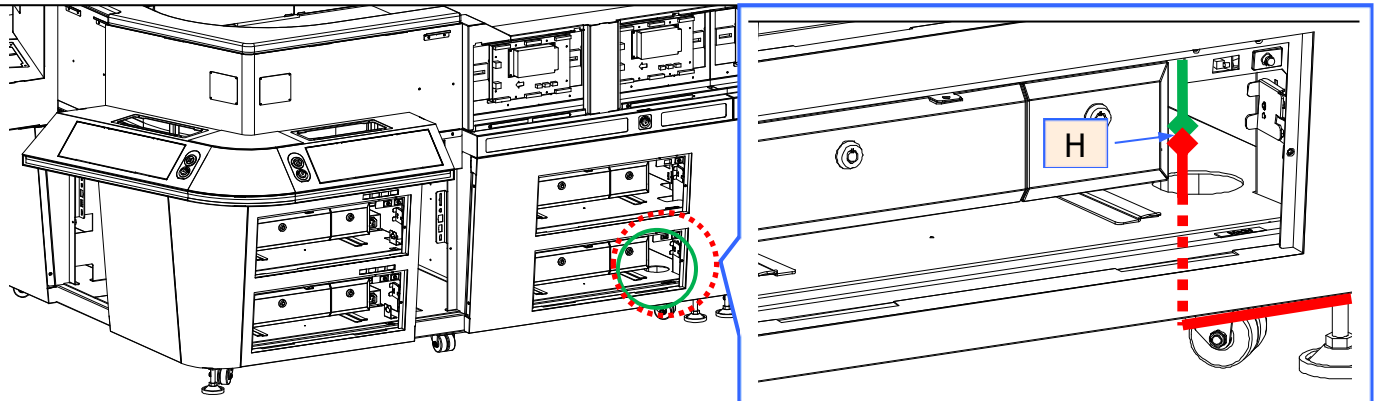

10. Connect again the WF(x4) Connectors of the Wall LED Cover, that were disconnected at STEP 13 of 3.2.7, to the WF1, WF2, WF3 and WF4 Connectors of the Wall LED Unit, and then affix with screws the Wall LED Covers.

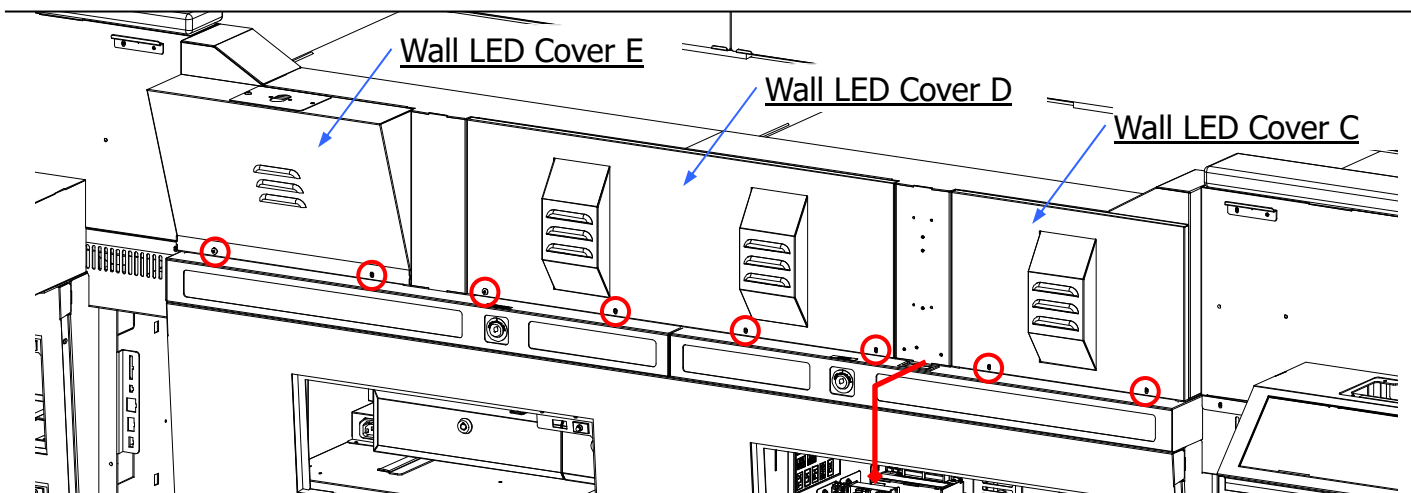
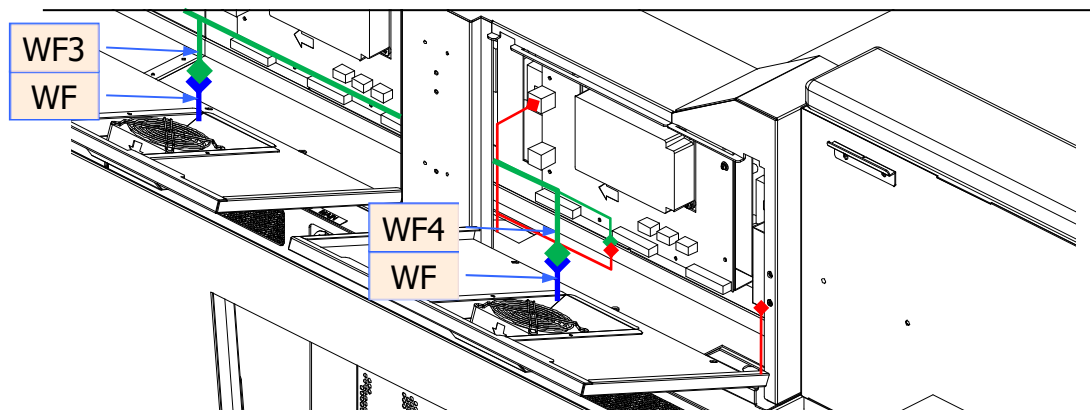

i NOTE: Option-6, 7

In case it was chosen the Option to install the Operation Stop Key Unit (option) or the Terminal Operation Button (Option), resume from here the procedure interrupted at 3.2.5. If the Option was not chosen, continue to **STEP 11**.

Option-6, 7 - 2

- I. Pass the RL Connector that was left inside the Center Unit A through the hole illustrate below, and insert it inside the Wall LED Unit.

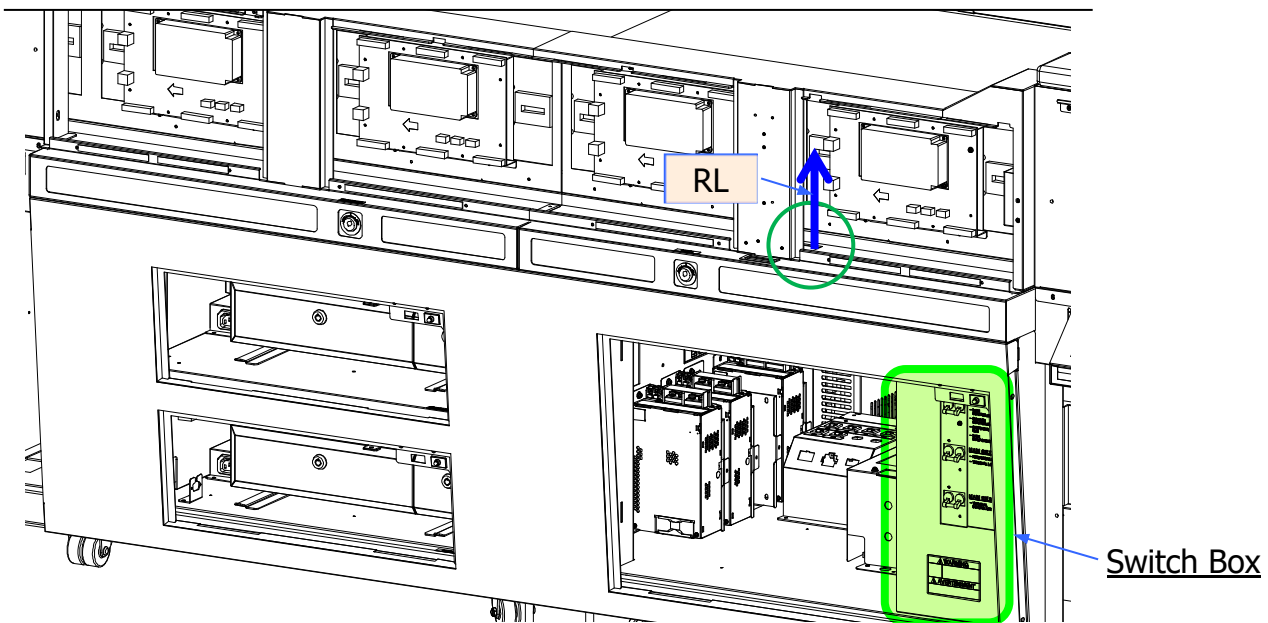

- II. Connect again the WF(x4) Connectors of the Wall LED Cover, that were disconnected at STEP 13 of 3.2.7, to the WF1, WF2, WF3 and WF4 Connectors inside the Wall LED Unit. Then connect the RL Connector of STEP I. to the RL Connector of the Wall LED Cover of **Option-6, 7**.

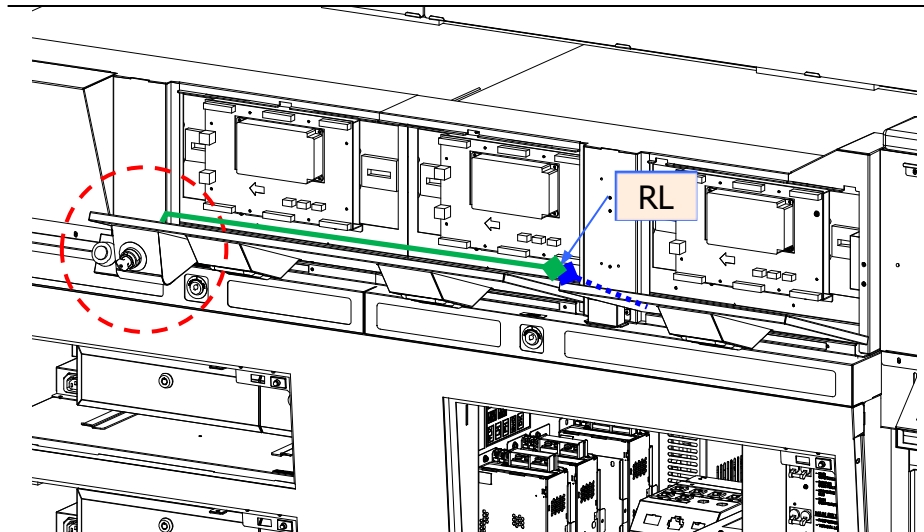
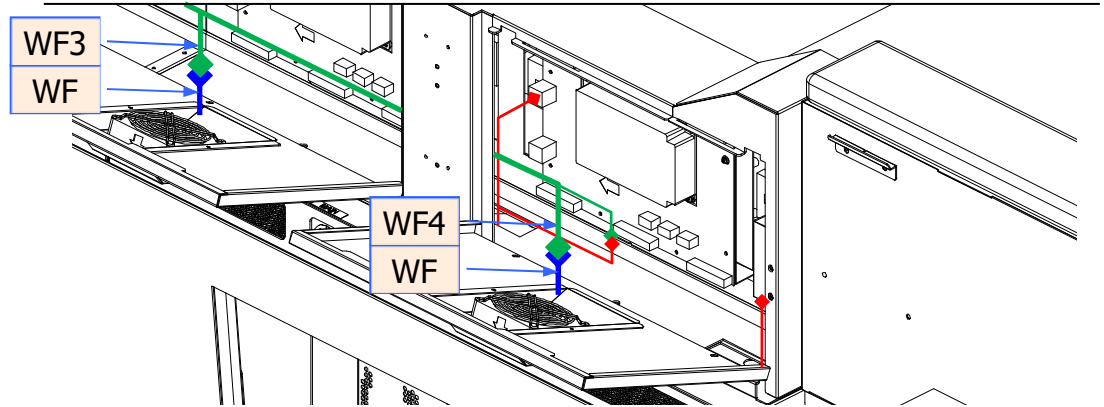

III. affix with screws the Wall LED Covers.

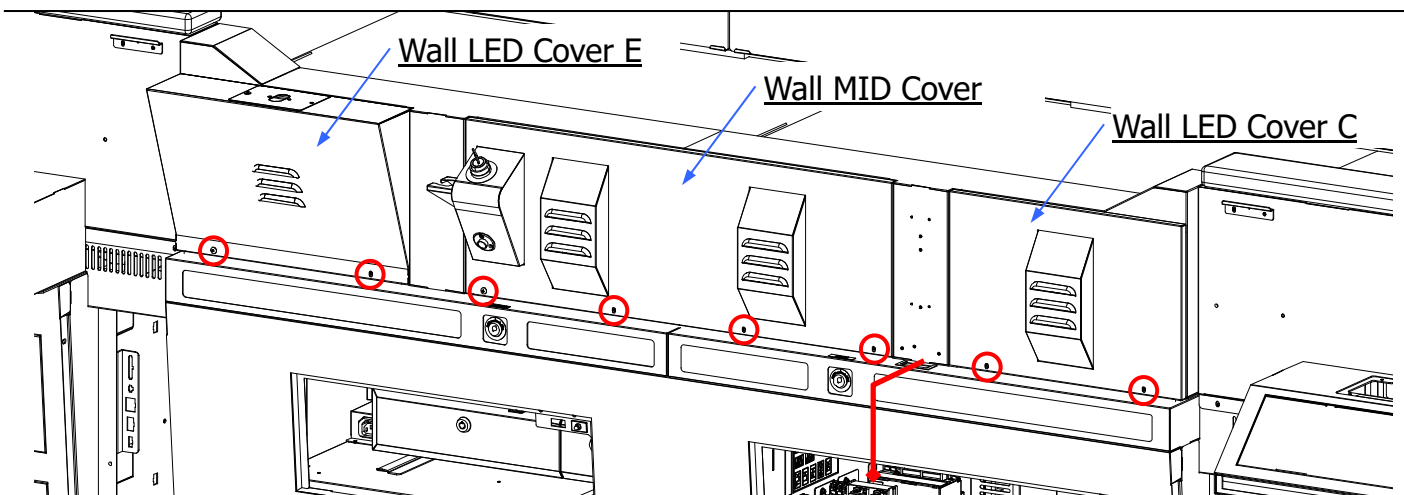

i NOTE: Option-7

Before starting the game operations, connect the Terminal Operation Button (Option).

Terminal Operation Button

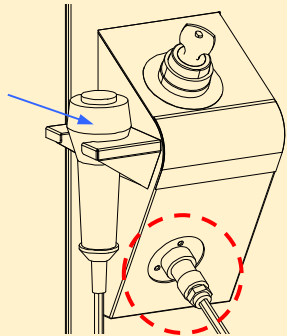

i NOTE: Option-6, 7

This completes the procedure specific for **Option-6, 7**. The procedure for the common installation continues from **STEP 11**.

11. Prepare the following Parts.

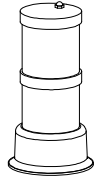
Parts Name	Qty	Appearance
Tower Light(OPTION)	1	

i NOTE: Option-1

In case it was chosen as **Option-3** to install the Tower Light over the History Display Unit (Refer to 3.2.16), there is no installation of the Tower Light. Please continue from **STEP 16**.

12. Remove the 2 screws of the Wall LED Cover E, then detach the Tower Light BRKT that is affixed to the upper side of the Wall LED Cover E.

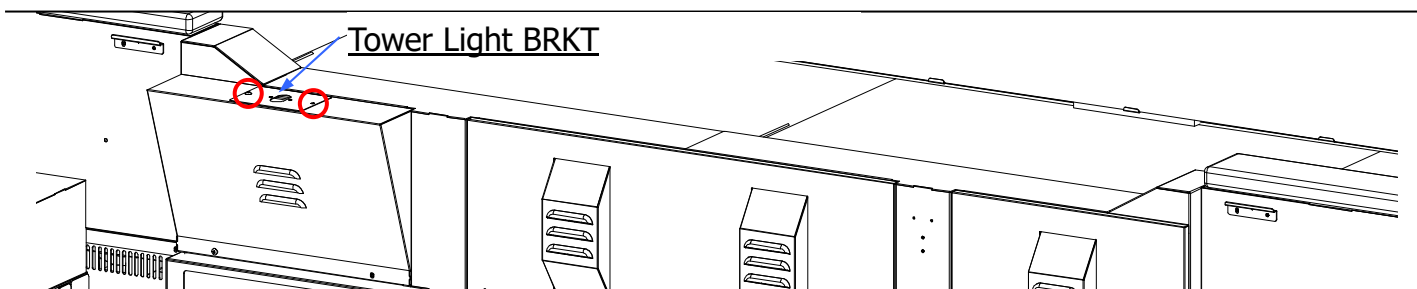

13. Thread the Tower Light harness through the hole on the Tower Light BRKT, and then affix the Tower Light by using the 2 screws (UNC#8-32-X5/8) that are located on the Tower Light.
14. Affix the earth cable terminal lug on the stud located on the backside of the Tower Light BRKT by using the nut (M4 flange).

Fasteners		Qty	Appearance
R	FLANGE NUT M4	1	

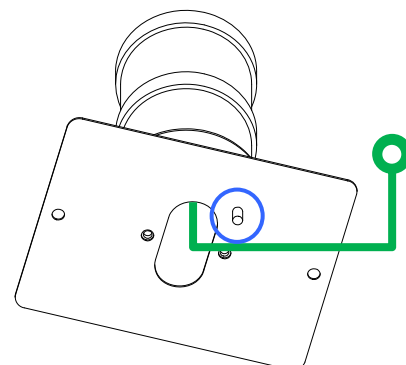
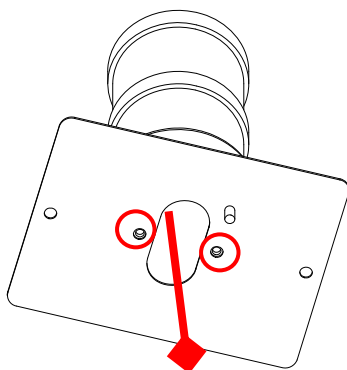

15. Connect the Tower Light Connector to the TLJ Connector that was wired inside the Wall LED Unit at STEP B), then affix the Tower Light BRKT to its previous position by using 2 screws, or the 2 screws that were removed before.

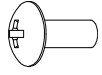
Fasteners		Qty	Appearance
Ab	TRUSS M4x8 BLK	2	

i NOTE:

Make sure that the screw nut on the top of the Tower Light is located on the backside.

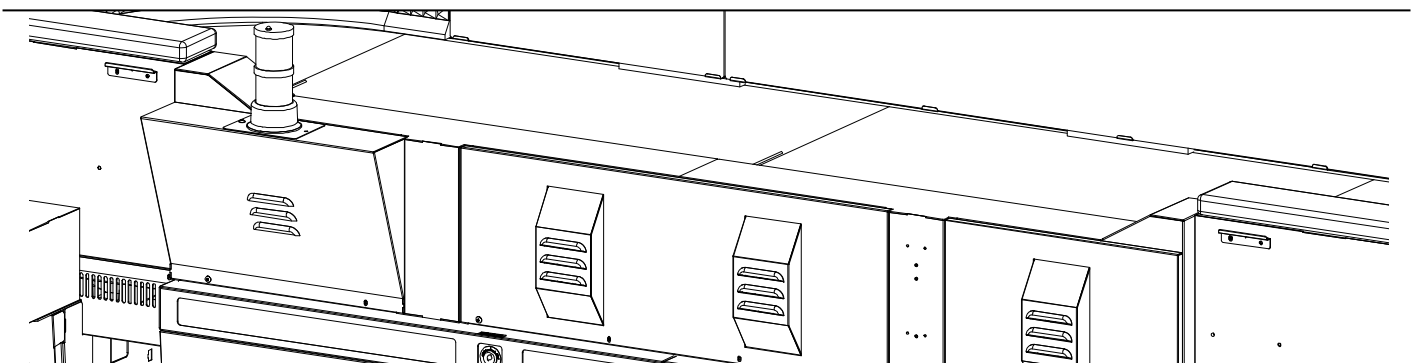
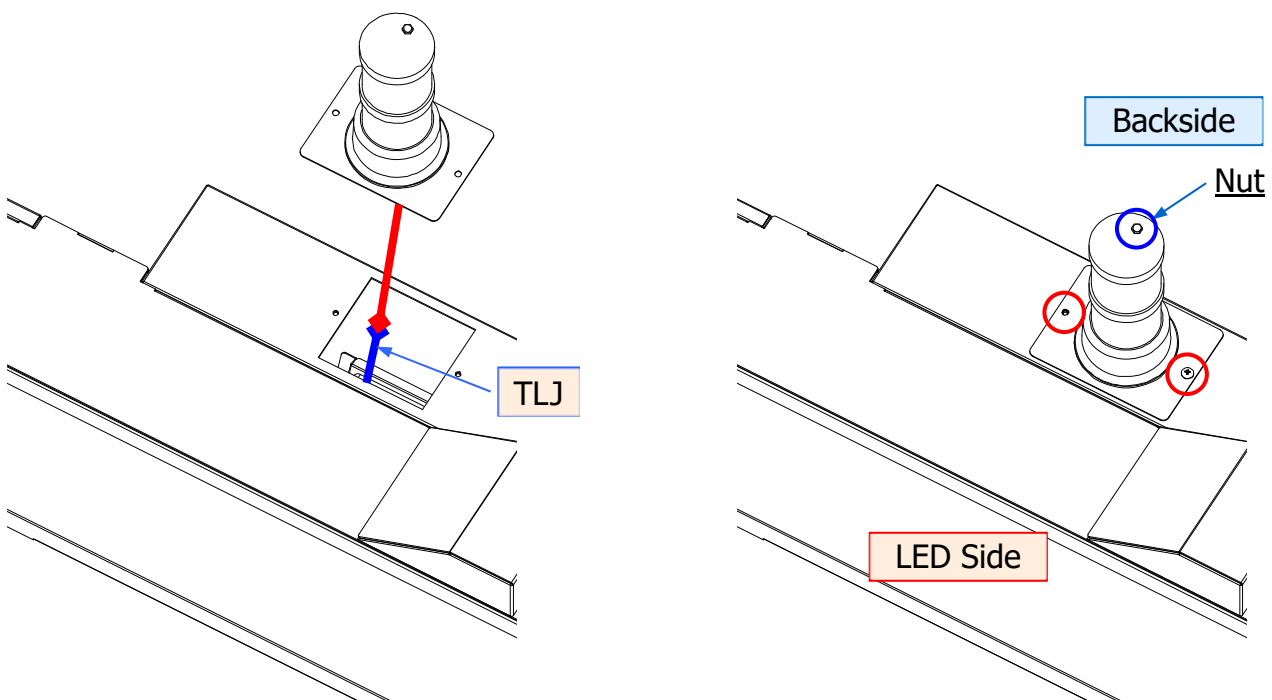

16. Prepare the following Parts.

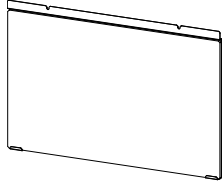
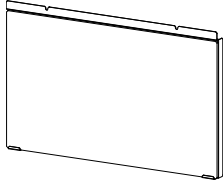
Parts Name	Qty	Appearance
Mirror R BRKT	1	
Mirror L BRKT	1	

17. While paying attention not to pinch any cable, place the Mirror R BRKT and the Mirror L BRKT at both sides of the Mirror Wall Unit (Wall C), and affix them with 2 screws for each.

Fasteners		Qty	Appearance
Ab	TRUSS M4x8 BLK	4	

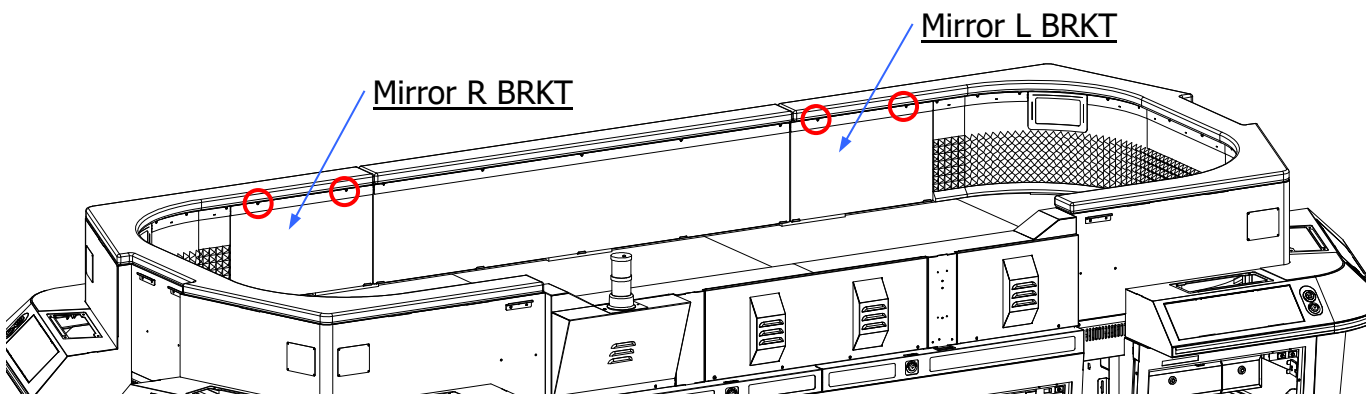

18. Untie the SP Connectors that are arranged inside the openings of the Wall Unit illustrated below.

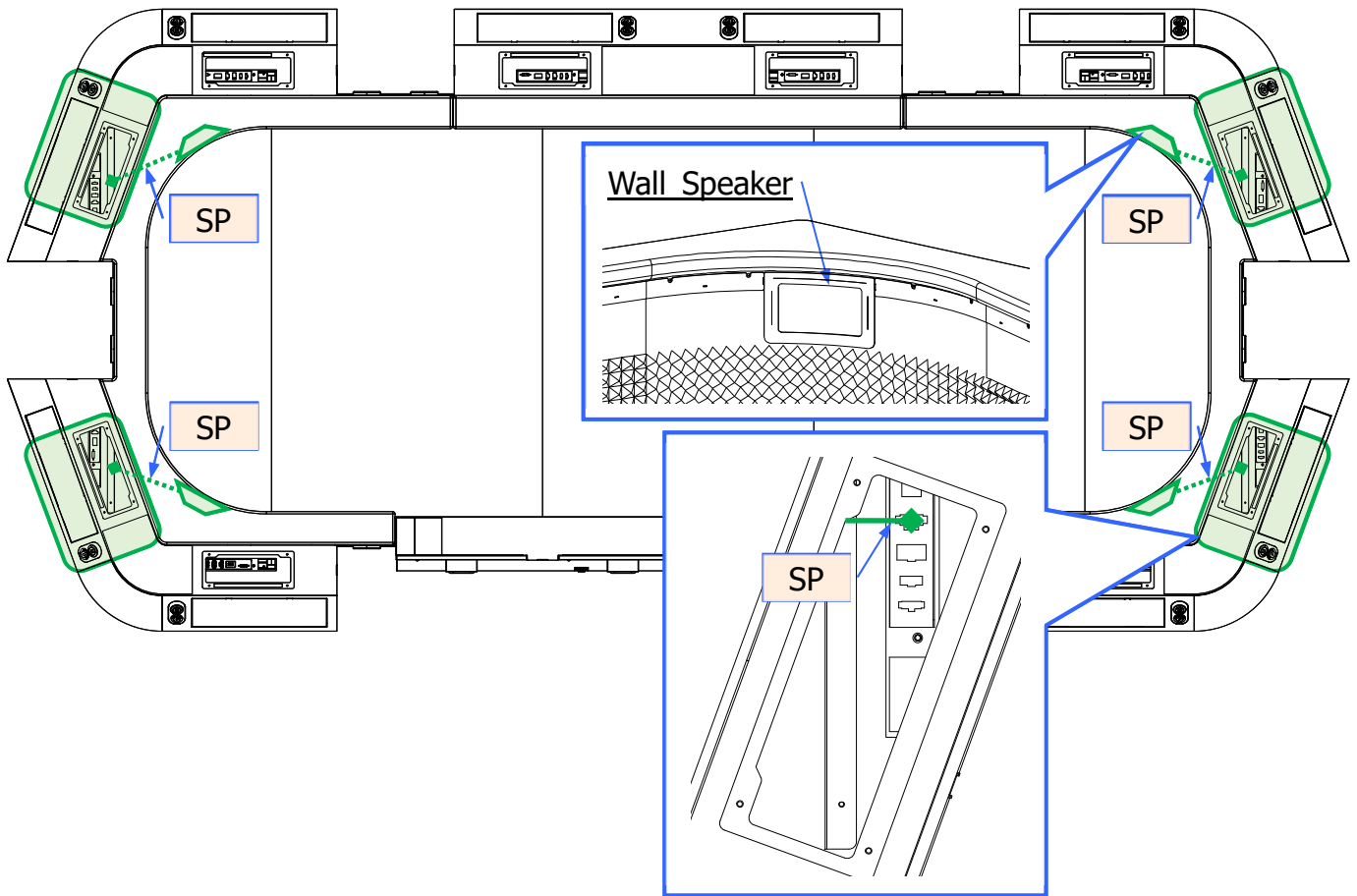

19. There is a Reset Key Switch for each Player Terminal. Untie the KY Connectors that are arranged inside the openings of the Wall Unit illustrated below, and connect all the KY Connector.

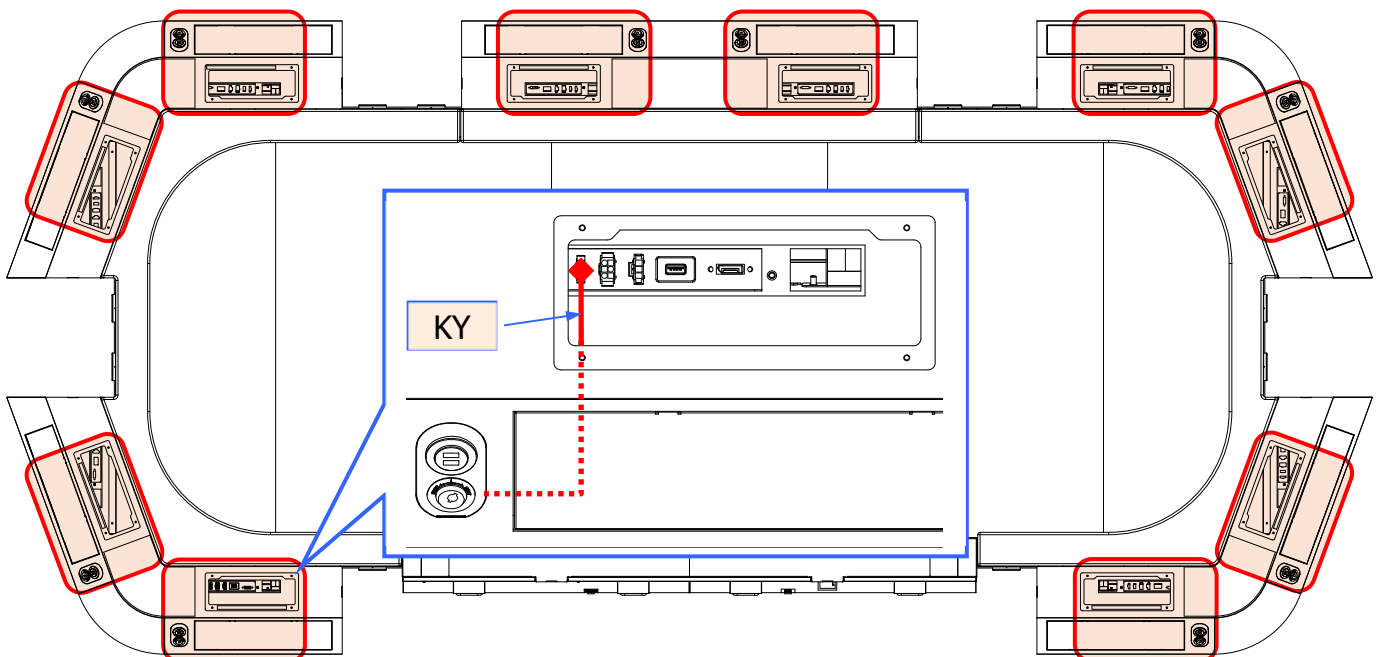

If the USB Socket (Option) is equipped

1. Prepare the following Parts.

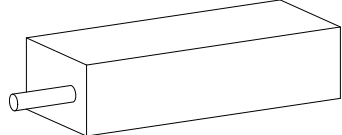
Parts Name	Qty	Appearance
AC/DC Adapter(Optional) (for USB Socket)	5	

2. Untie the CG Connectors that are arranged inside the openings of the Wall Unit illustrated below, and connect them to the CG Connectors of the AC/DC Adapter. Pull the AC/DC Adapters of the AC Cable inside the Center Unit through the hole indicated below.

NOTE:

There is a 1 CG Connector for the USB Socket (Option) for each 2 Player Terminal.

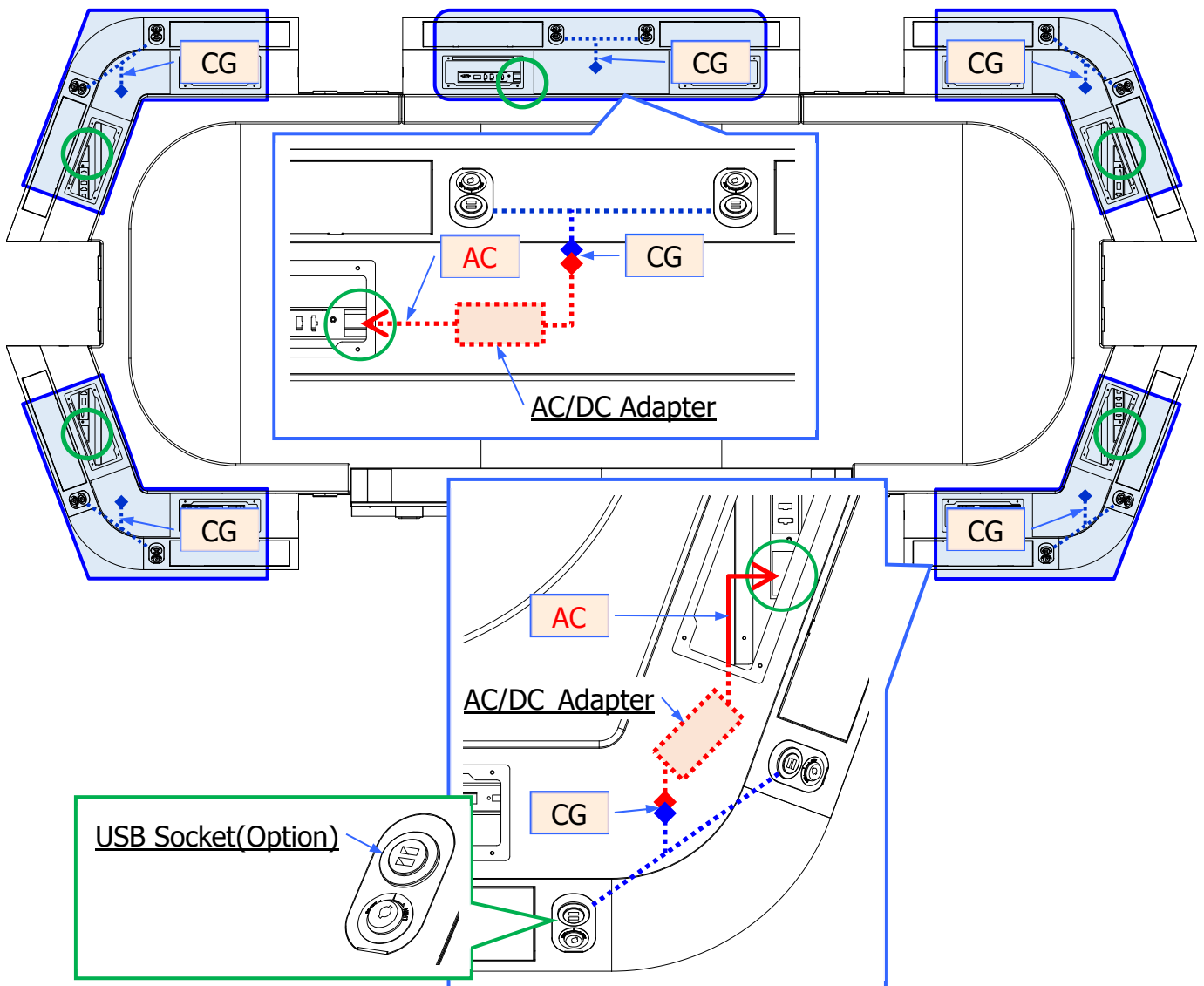

3. Lead the AC Plug of the AC/DC Adapter through the path indicated below, and then pull out them one by one, and connect them to the previously prepared power sockets.

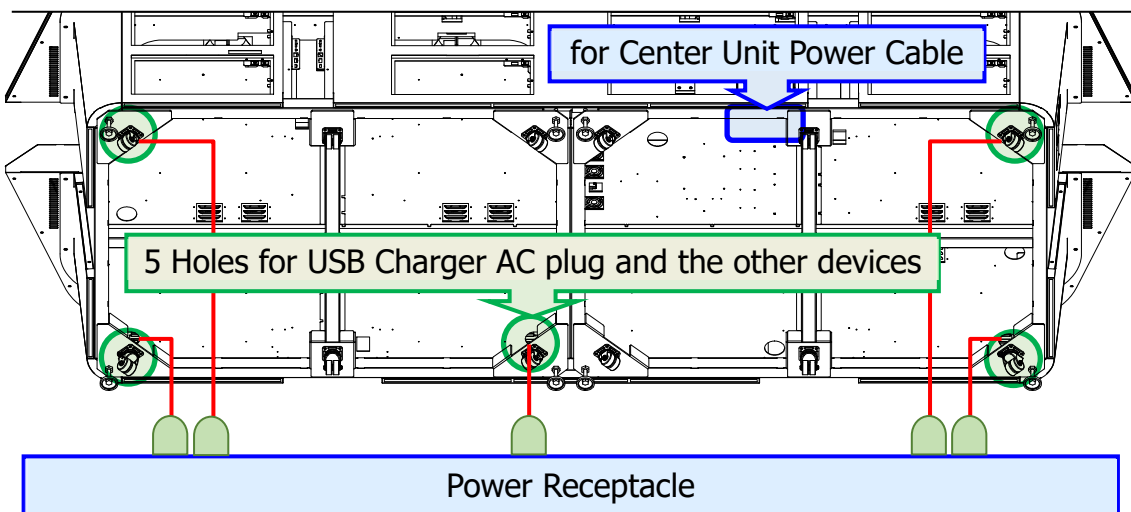
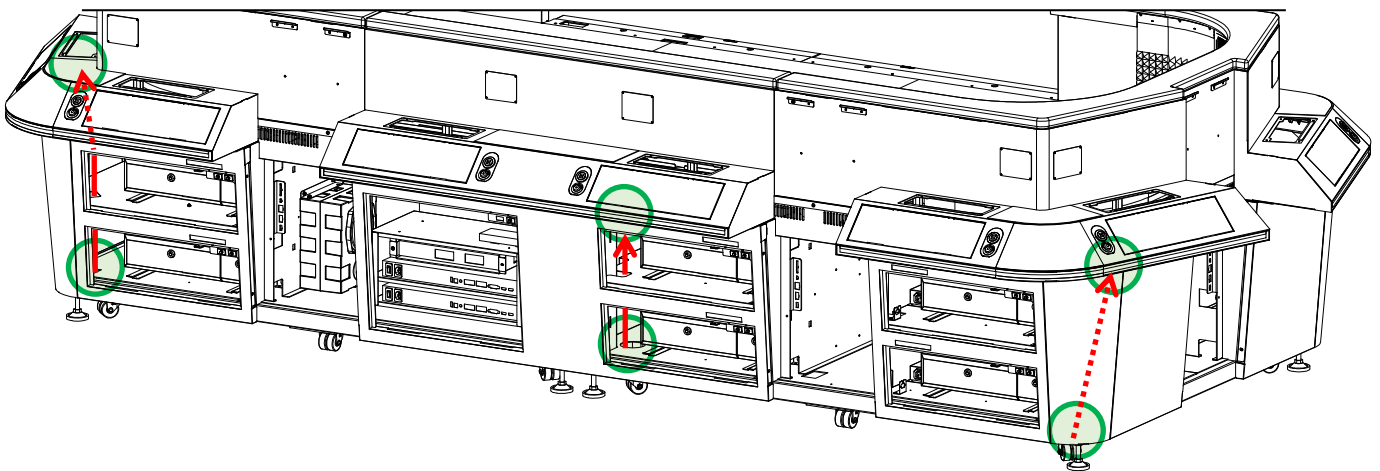
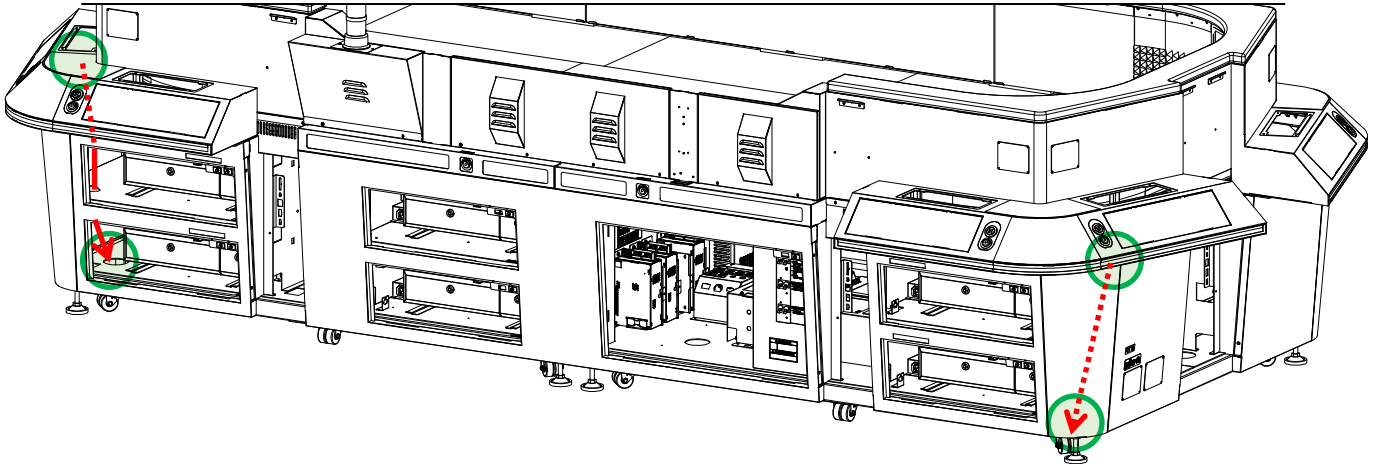

3. 2. 9: Precheck of the Wall LED Unit

CALL SERVICE IMMEDIATERY!

Before proceeding with the installation, check if the images on the Wall LED Unit are correctly displayed. If the images are not correctly displayed, it is necessary to re-install the setting program. Please contact the Customer Technical Support.

NOTE:

For this operation it is necessary a Notebook PC supporting a cable for HDMI port.

1. Unplug the HDMI Cable connected to the LED Controller Unit as illustrated below, and substitute it with the HDMI Cable from the Notebook PC.

NOTE:

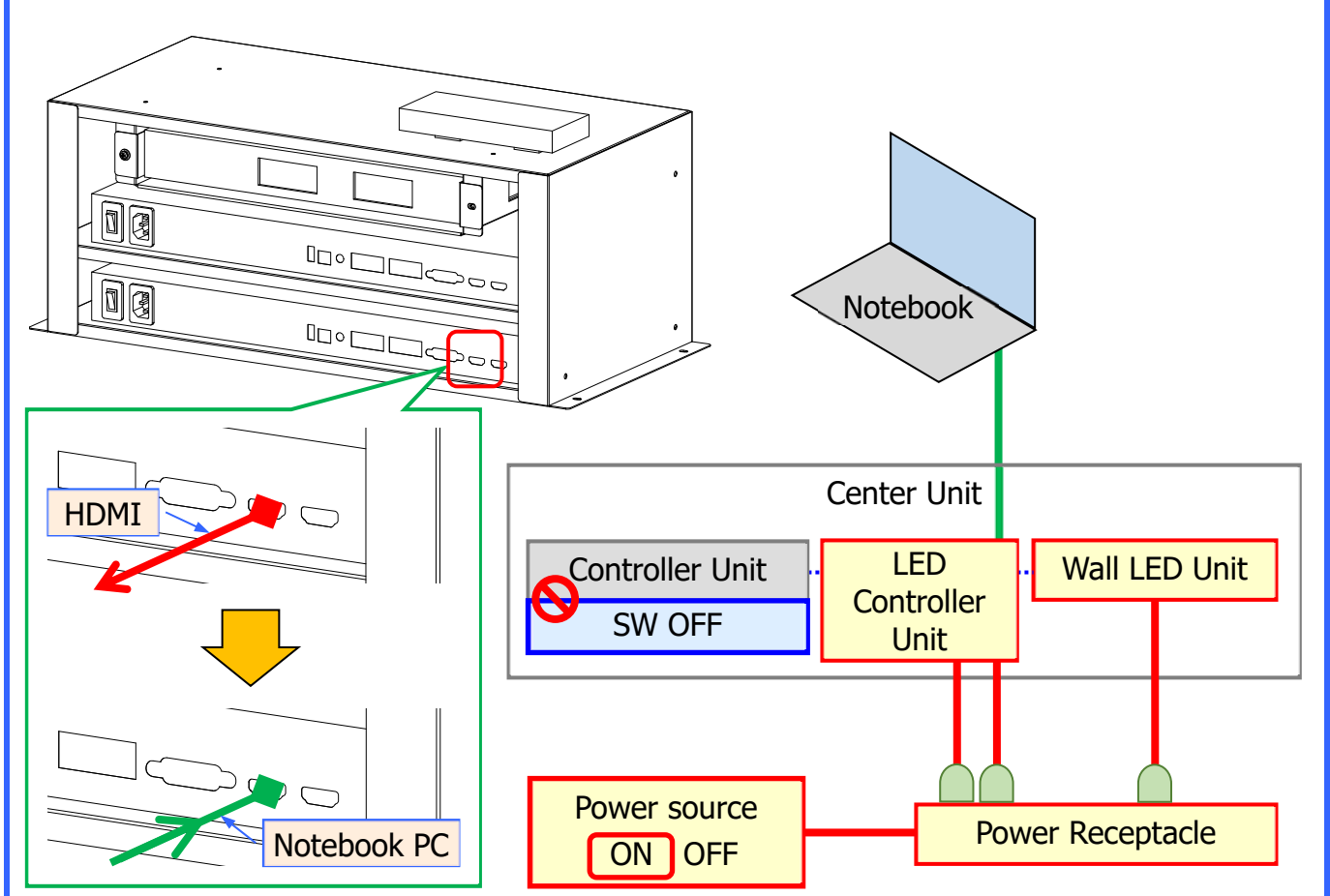

2. First turn ON the power source. The machines directly connected to the power source will boot up.
3. As the images are outputted from the Notebook PC, the Wakk LED Unit will show them, making it possible to check if the display works correctly.
4. After the check on the Wall LED Unit is concluded, turn OFF the power source to turn OFF the machine. Reconnect as it was previously the HDMI Cable disconnected at STEP 1.

3. 2. 10: Installing the Ticket Printer and Validator Unit – Single type

i NOTE:

There are two categories of Ticket Printer and Validator Unit: the Single type, for 1 Player Terminal, and the Double Type, for 2 Player Terminals.

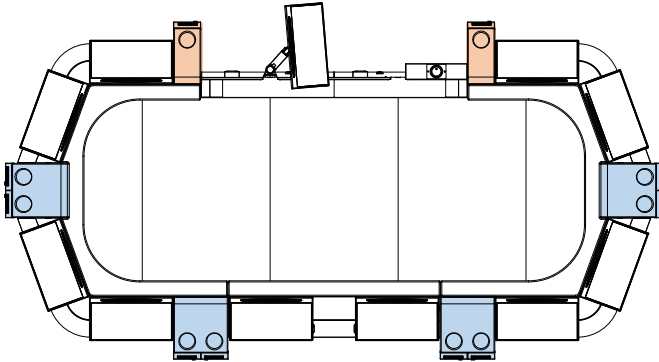

Ticket Printer and Validator Unit

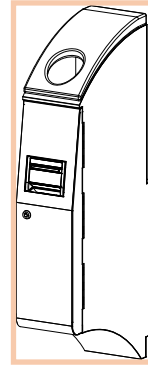

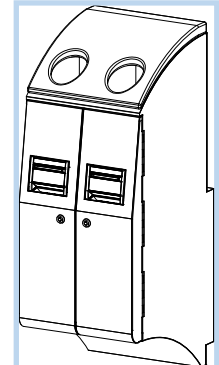

Single type



Double Type

1. Prepare the following Parts.

Parts Name	Qty	Appearance
Ticket Printer and Validator Unit (BV Case A) for the Player Terminals No.1(Left side)	1	
Ticket Printer and Validator Unit (BV Case C) for the Player Terminals No.10(Right side)	1	

i NOTE:

If the locks are changed for increased security, please refer to "**Key Locks**" on Chapter 3 of the SERVICE MANUAL to perform the work.

- While paying attention not to pinch any connector or cable, hang the Ticket Printer and Validator Units (BV Case A and C) to the hooks on the Center Unit, by the hole on the upper part of its back. Do not mistake the right and the left Unit.

⚠ CAUTION!

The Ticket Printer and Validator Unit is difficult to hold. Please be careful during the procedure.

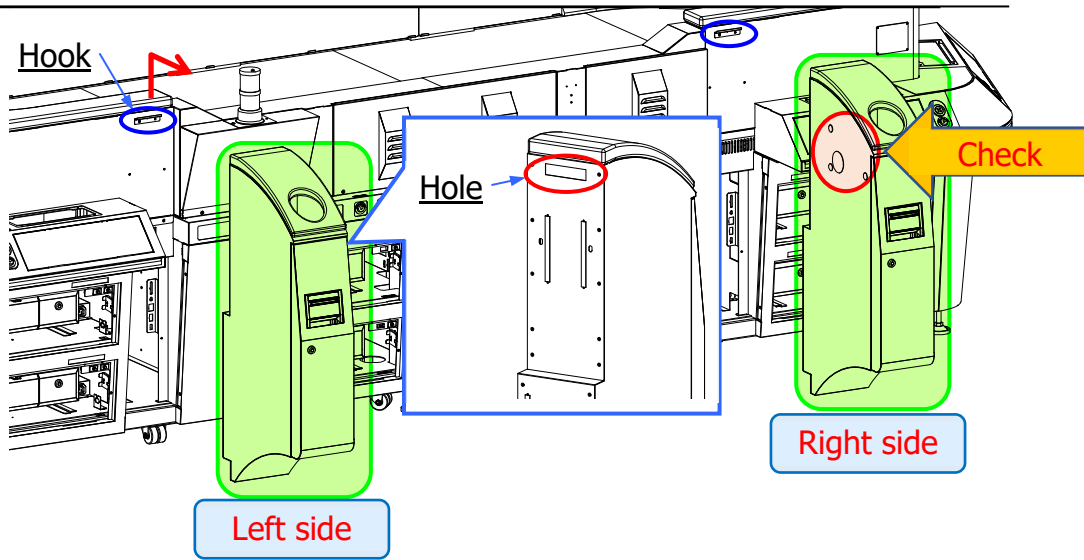

- Unlock and open the door of the Ticket Printer and Validator Units (BV Case A and C), and affix them to the Center Unit from the inner side of the Ticket Printer and Validator Unit (BV Case A and C) by using 4 screws.

Fasteners		Qty	Appearance
L	HEX UPSET M6 x 12 3P	8	

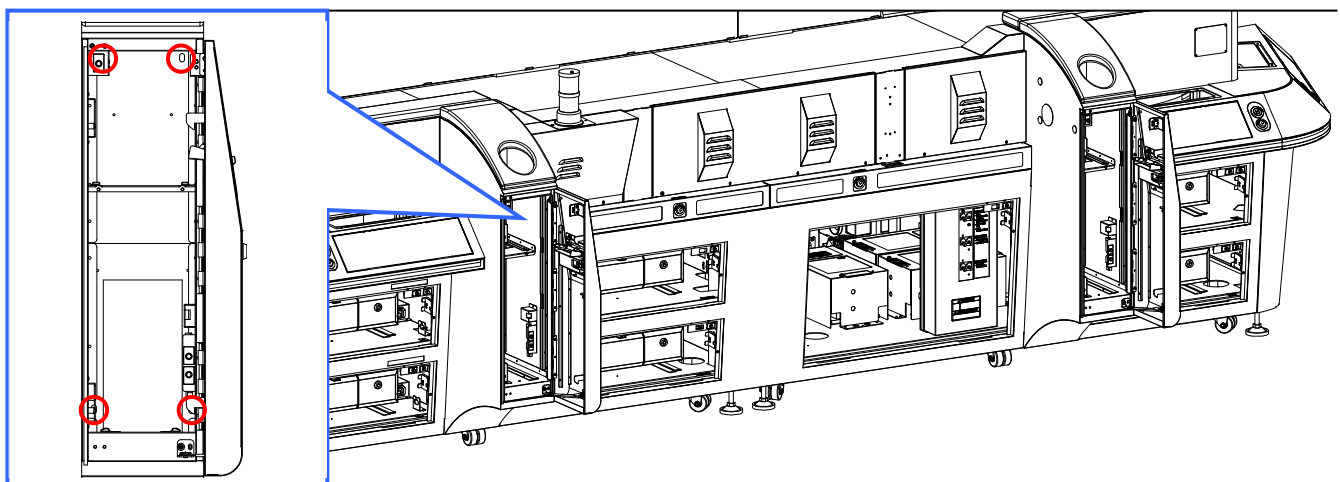

- Untie the LV, LX1 and PRC Connectors that are arranged inside each Ticket Printer and Validator Unit (BV Case A and C), and connect them to the LV, LX1 and PR Connectors of the Center Unit.

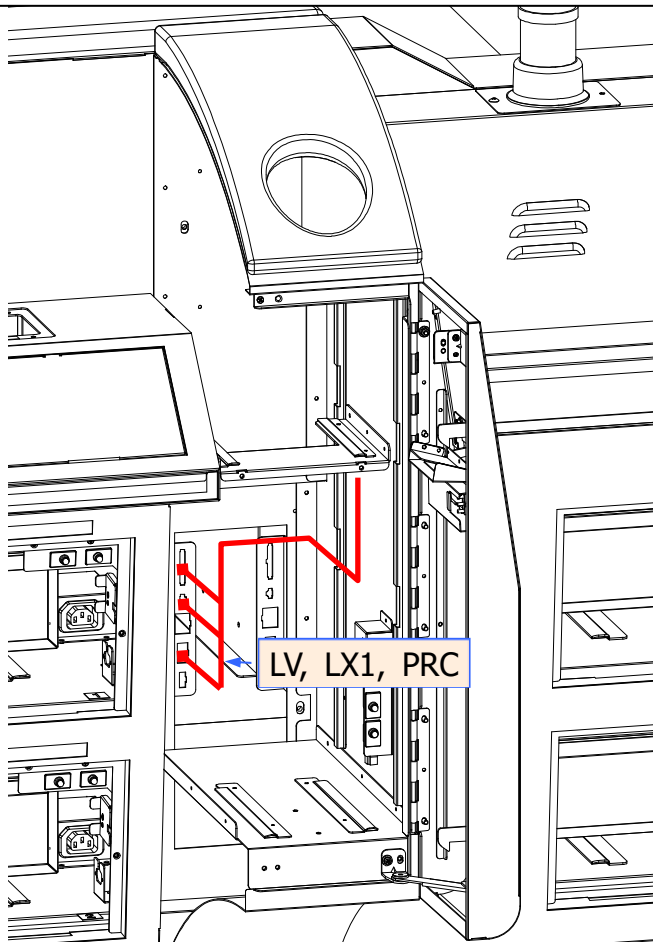

Left side

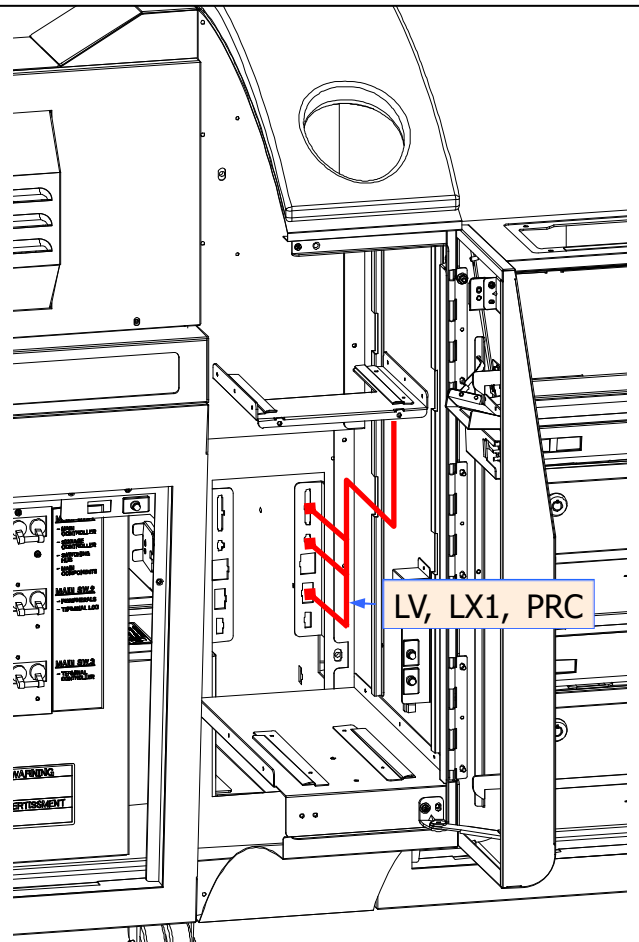

Right side

i NOTE: Option-2

In case it was chosen the Option to use the Tipping System Unit (Option), resume from here the procedure interrupted at 3.2.5. If this Option was not chosen, continue to **STEP 5**.

Option-2 - 2

- A) Remove the 5 nuts inside the Ticket Printer and Validator Unit (BV Case C : **Right side**) to detach the Blind Plate. ※It is possible that the Blind Plate is already detached at the time of the delivery.

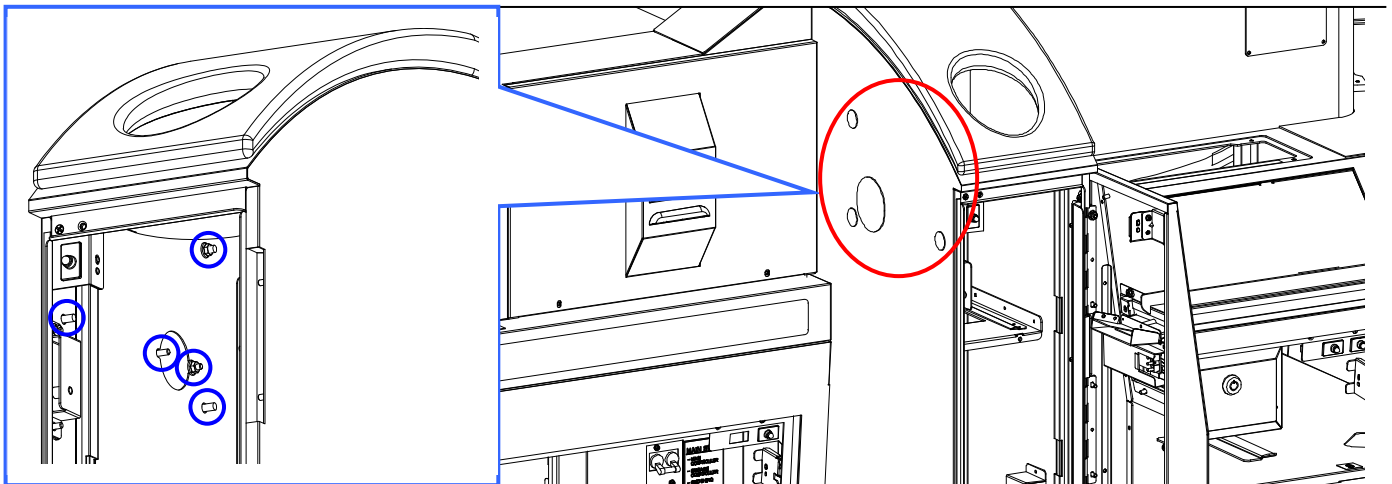

- B) Prepare the following Parts.

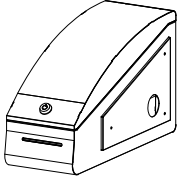
Parts Name	Qty	Appearance
Tipping System Unit(Optional)	1	

- C) Affix the Tipping System Unit to the Ticket Printer and Validator Unit (BV Case C : **Right side**) by using 3 screws on the inner side.

Fasteners		Qty	Appearance
I	PAN M5x10 3P	3	

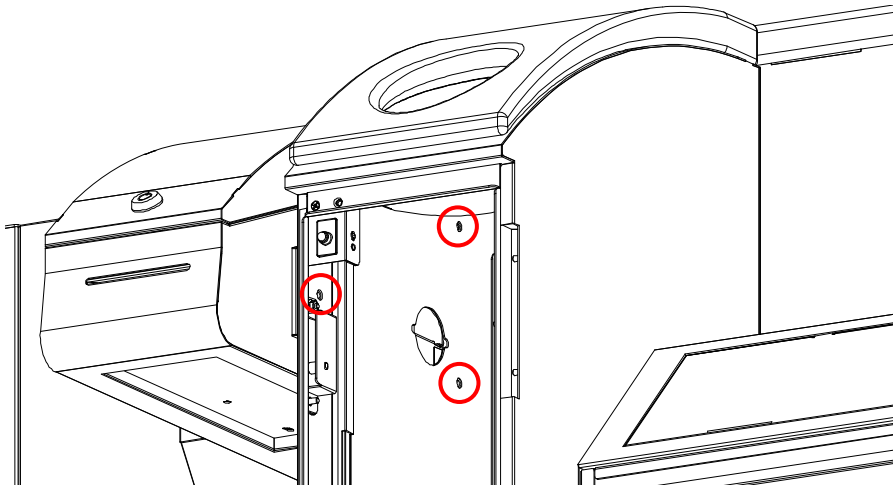

- D) Untie the Cables arranged inside the Tipping System Unit. Pull the CS and USB Connector inside the Ticket Printer and Validator Unit (BV Case C : **Right side**) through the hole on the side, then connect them to the CS and USB Connector that are arranged at the back of the Switch Box of the Center Unit.

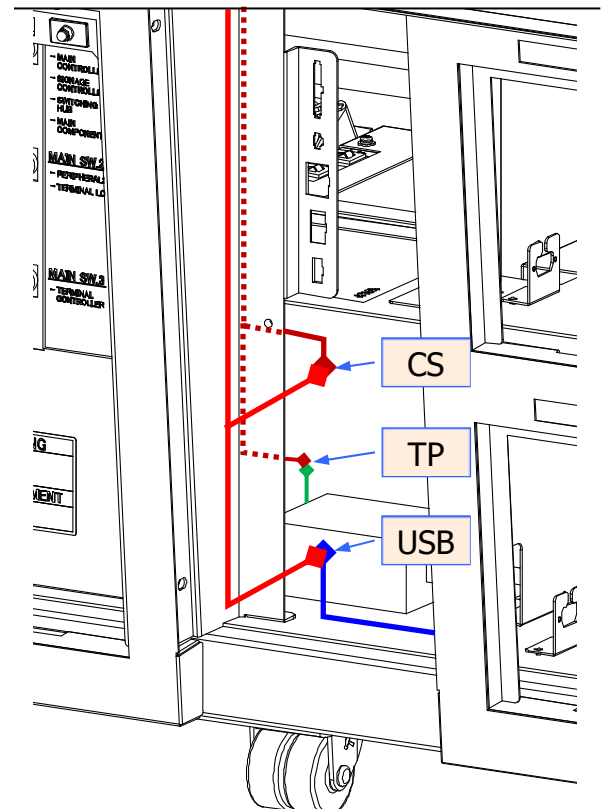
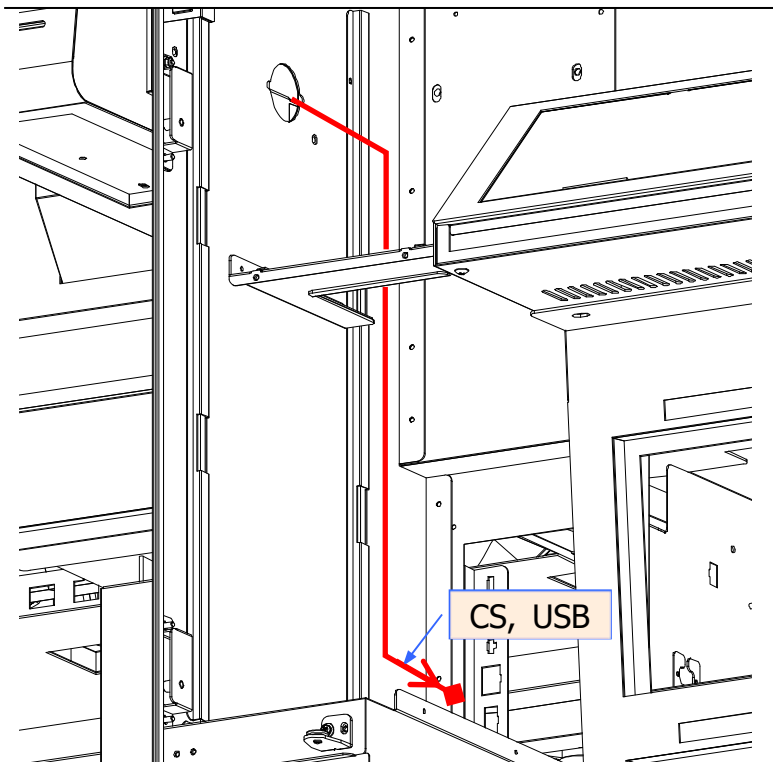

E) Prepare the following Parts.

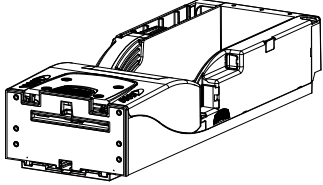
Parts Name	Qty	Appearance
Ticket Printer Unit	1	

F) Connect the PRN Connector inside the Tipping System Unit to the Printer Unit, then affix the Ticket Printer Unit to the Tipping System Unit by using 4 screws.

Fasteners	Qty	Appearance
Ab TRUSS M4x8 BLK	4	

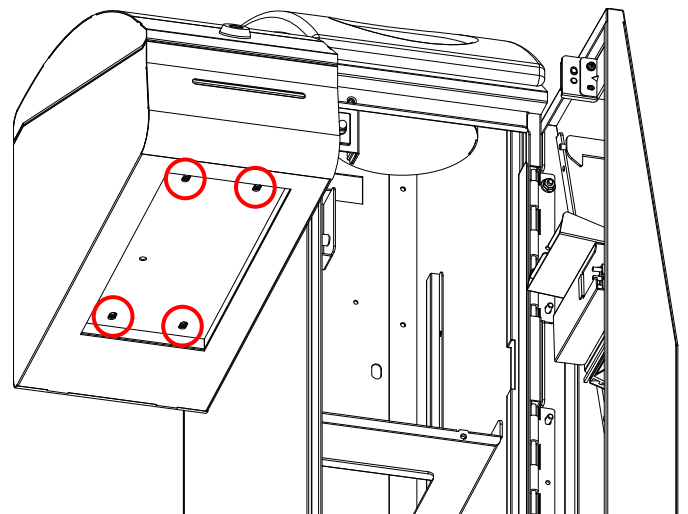
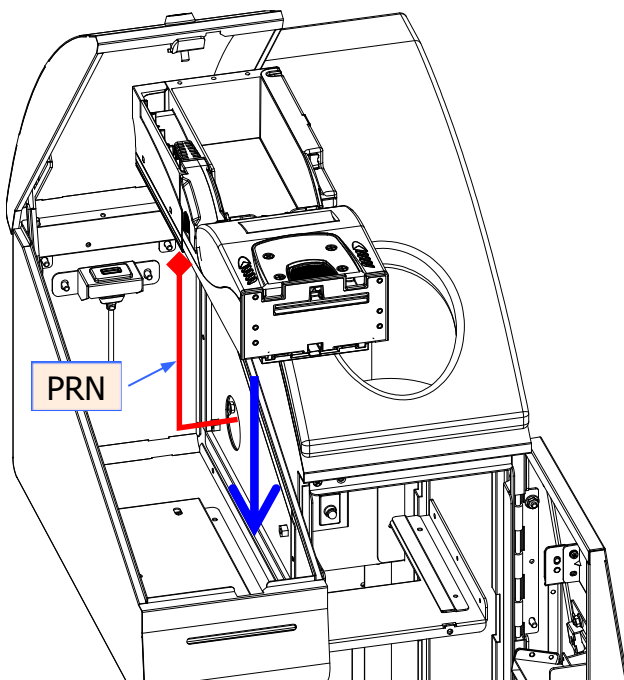

i NOTE: Option-2

This completes the procedure specific for **Option-2**. The procedure for the common installation continues from **STEP 5**.

5. Prepare the following Parts.

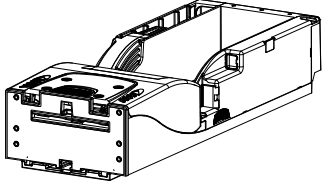
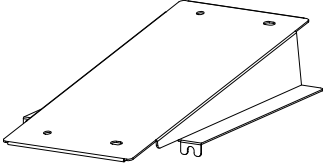
Parts Name	Qty	Appearance
Ticket Printer Unit	2	
Printer BRKT	2	

6. Affix with 4 screws the Printer BRKT to the reverse side of the Ticket Printer.

Fasteners	Qty	Appearance
F PAN M4X8 3P	8	

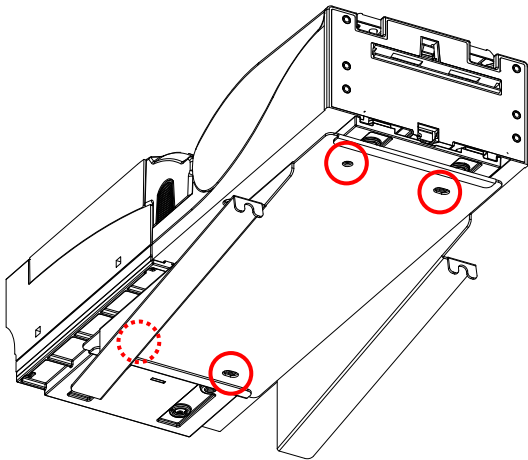

7. Connect the PRN Connector that is inside the Ticket Printer and Validator Unit (BV Case A) to the Ticket Printer, and then install the Ticket Printer Unit.

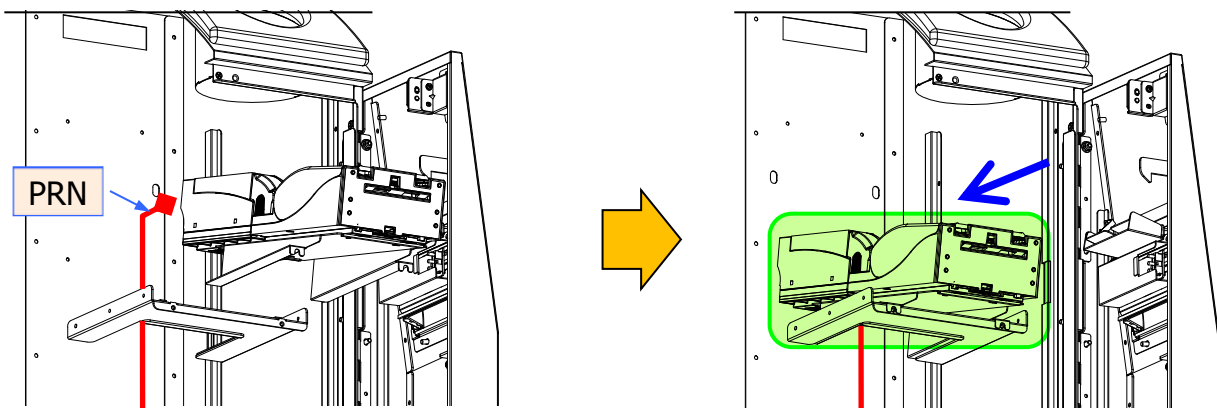

8. Affix the Ticket Printer Units to the Ticket Printer and Validator Unit (BV Case A) by using 2 screws on each.

Fasteners		Qty	Appearance
F	PAN M4X8 3P	4	

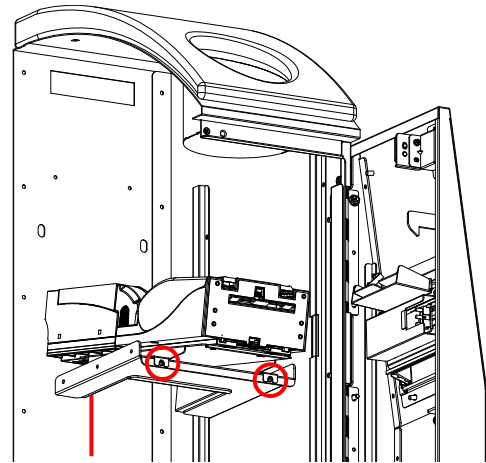

9. Prepare the following Parts.

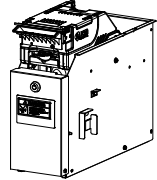
Parts Name	Qty	Appearance
Validator Unit and Accessory Cable	2	

i NOTE:

If the locks are changed for increased security, please refer to "**Key Locks**" on Chapter 3 of the SERVICE MANUAL to perform the work.

10. Connect the Accessory Cable to the Validator Unit, and thread the BR and the LX2 Connectors on the opposite side through the hole indicated below.

⚠ CAUTION!

The Cable connected to the Validator must pass through the hole at the back side of the Validator Unit.

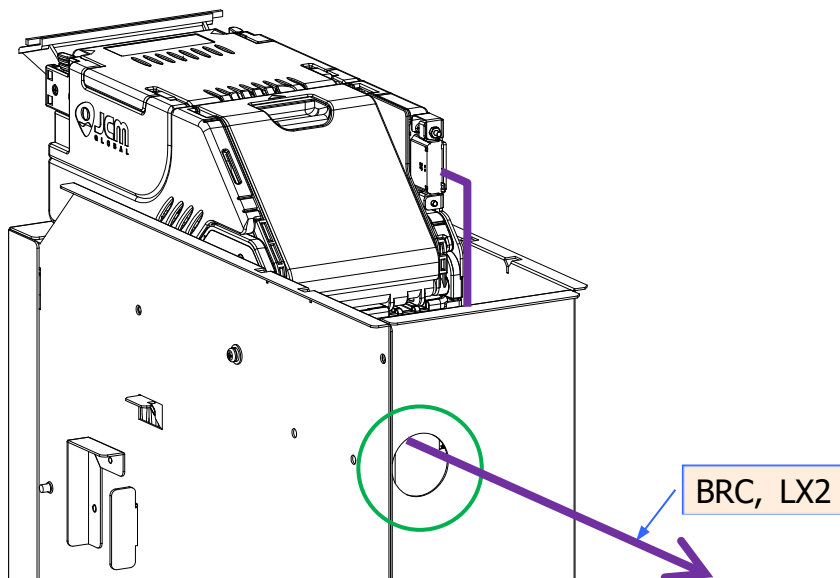

11. Connect the BR and LX2 Connectors to the BR and LX2 Connectors of the Center Unit.



12. While paying attention not to damage any Cable, install the Validator Unit inside the Ticket Printer and Validator Unit (BV Case A).

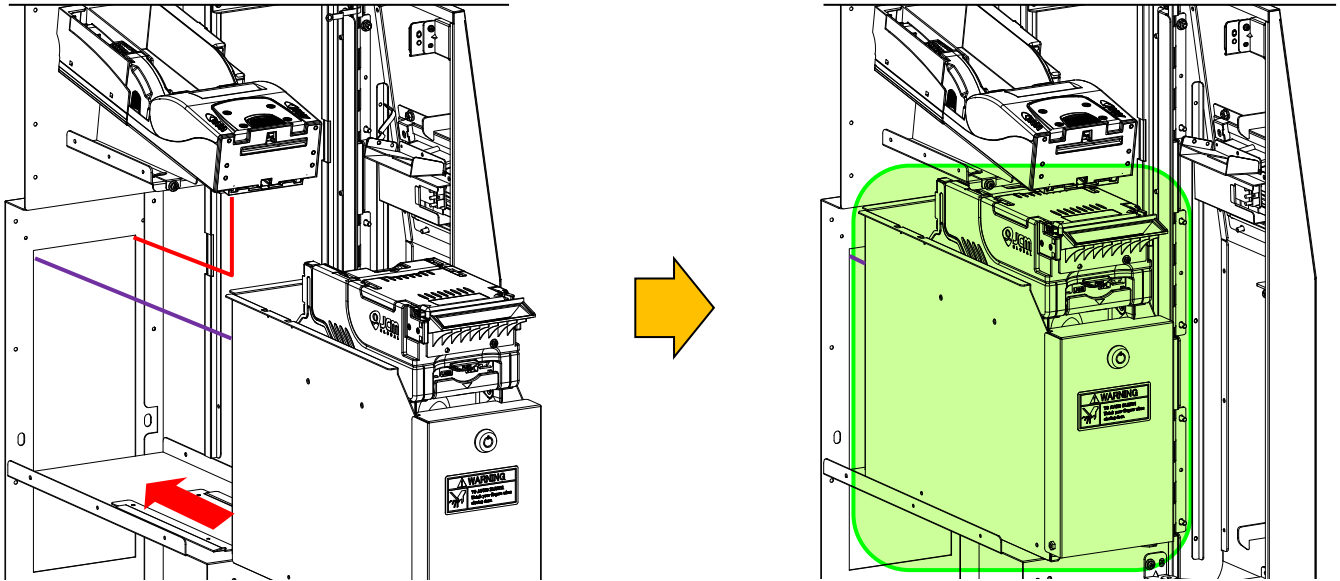

13. Draw out the Stacker from the Validator Unit, and affix the Validator Unit by using 2 screws.

Fasteners		Qty	Appearance
F	PAN M4X8 3P	4	

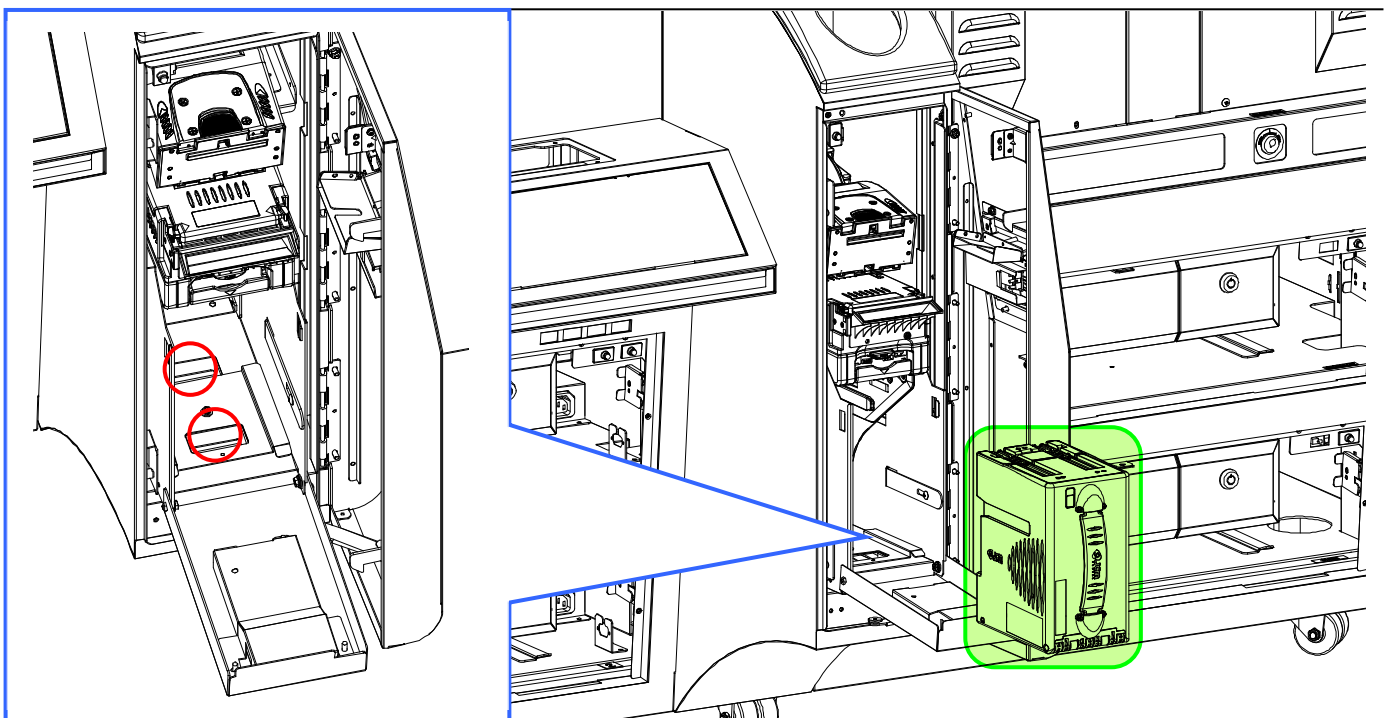

14. Return the Stacker to its position and then close the Ticket Printer Validator Unit (BV Case A).

3. 2. 11: Installing the Ticket Printer and Validator Unit – Double type

i NOTE:

There are two categories of Ticket Printer and Validator Unit: the Single type, for 1 Player Terminal, and the Double Type, for 2 Player Terminals.

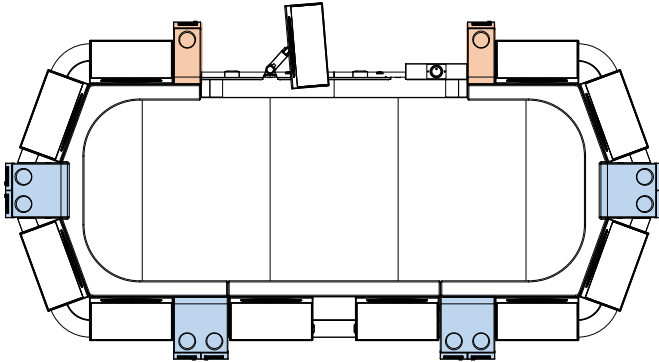

Ticket Printer and Validator Unit

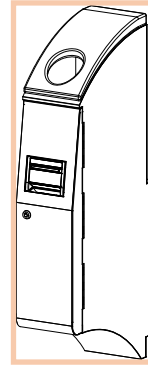

Single type

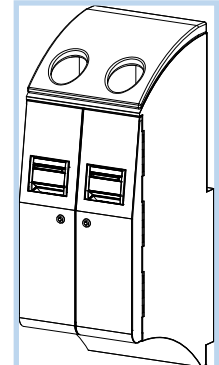

Double Type

1. Prepare the following Parts.

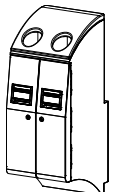
Parts Name	Qty	Appearance
Ticket Printer and Validator Unit (BV Case B) for the Player Terminals Nos.2 - 3(or Nos. 4 - 5, Nos. 6 - 7, Nos. 8 - 9)	4	

i NOTE:

If the locks are changed for increased security, please refer to “**Key Locks**” on Chapter 3 of the SERVICE MANUAL to perform the work.

2. While paying attention not to pinch any connector or cable, hung the Ticket Printer and Validator Units (BV Case B) to the hooks on the Center Unit, by the hole on the upper part of its back.

⚠ CAUTION!

The Ticket Printer and Validator Unit (BV Case B) is difficult to hold. Please be careful during the procedure.

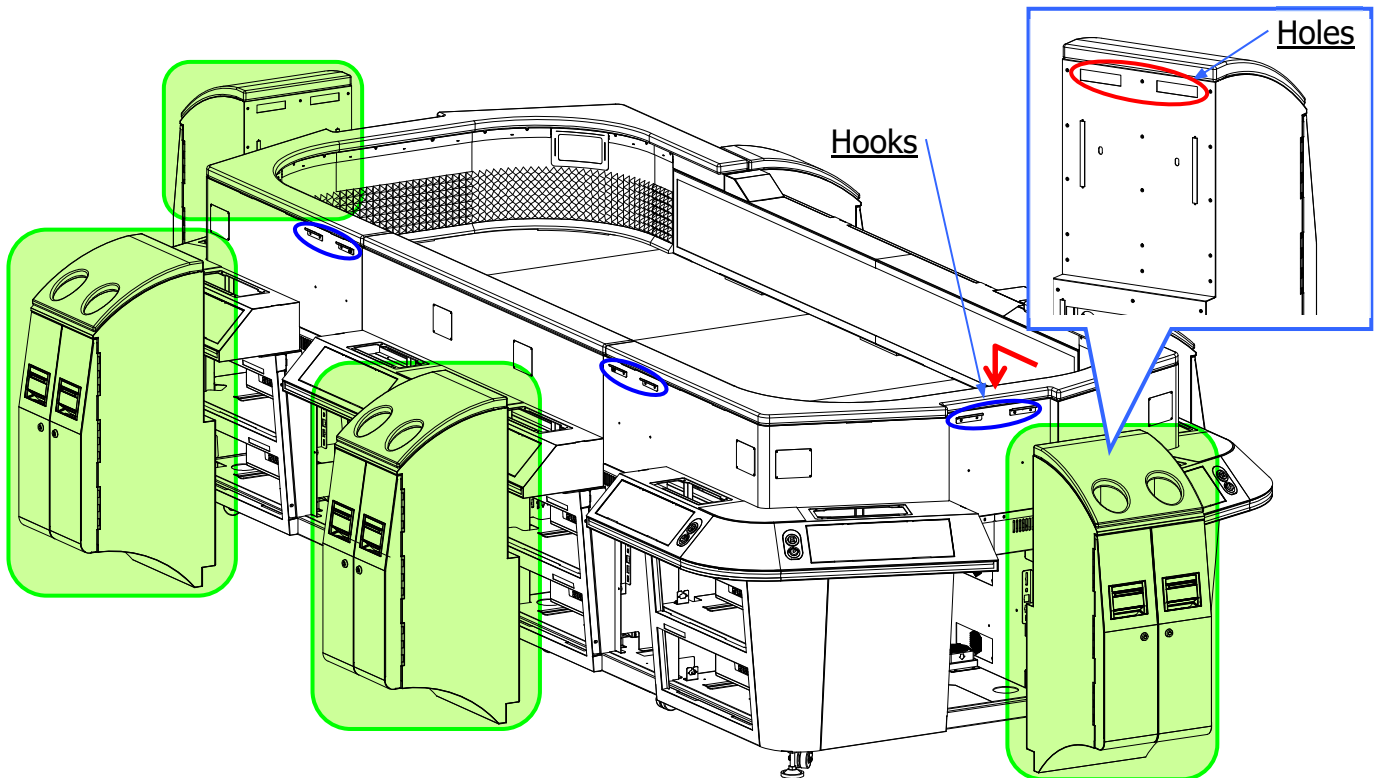

- Unlock and open the door of the Ticket Printer and Validator Units (BV Case B), and affix them to the Center Unit from the inner side of the Ticket Printer and Validator Unit (BV Case B) by using 4 screws.

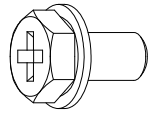
Fasteners		Qty	Appearance
L	HEX UPSET M6 x 12 3P	16	

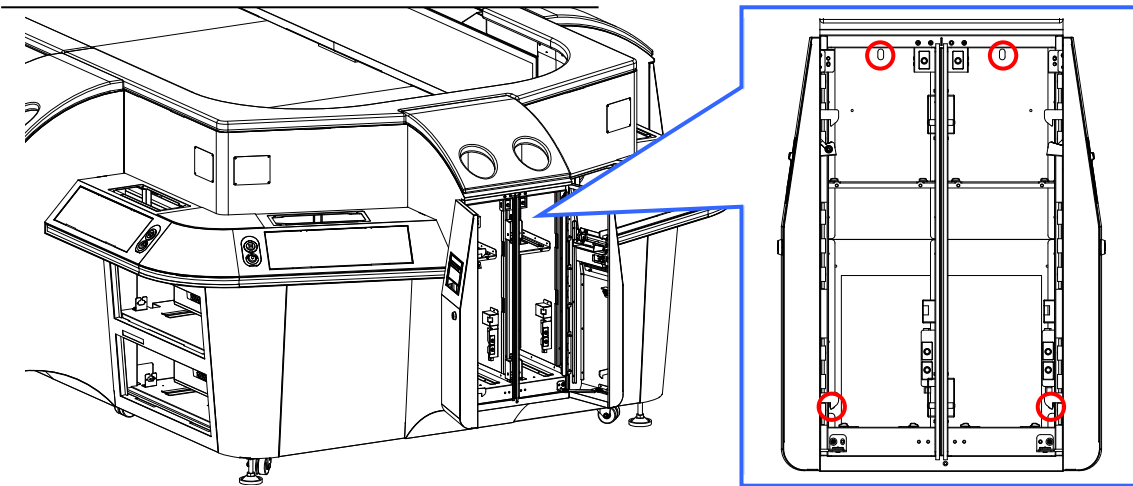

- Untie the LV, LX1 and PRC Connectors that are arranged inside each Ticket Printer and Validator Unit (BV Case B), and connect them to the LV, LX1 and PR (or PR1, PR2) Connectors of the Center Unit.

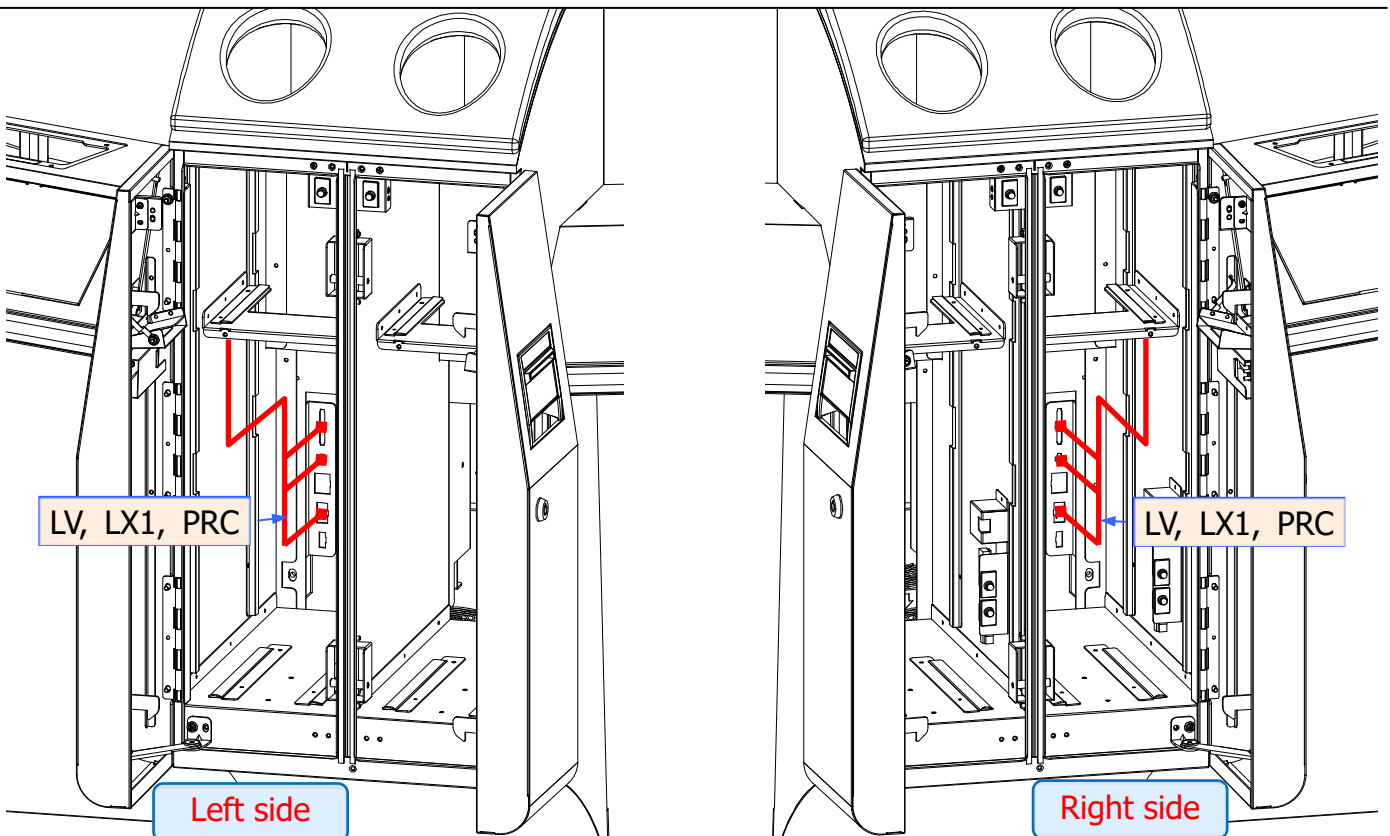

5. Prepare the following Parts.

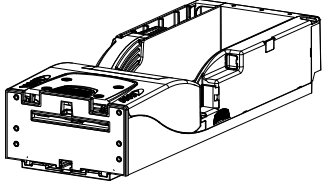
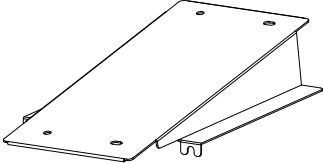
Parts Name	Qty	Appearance
Ticket Printer Unit and Accessory Cable	8	
Printer BRKT	8	

6. Affix with 4 screws the Printer BRKT to the reverse side of the Ticket Printer.

Fasteners	Qty	Appearance
F PAN M4X8 3P	32	

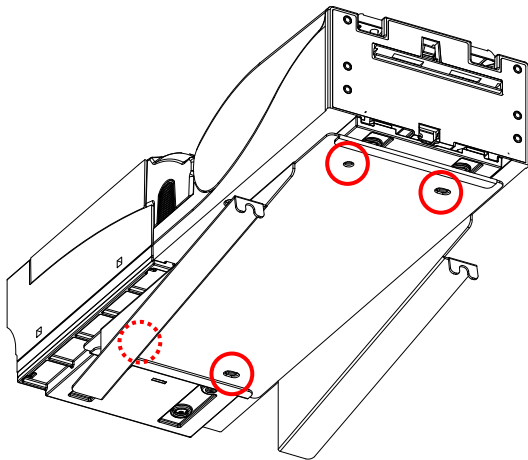

7. Connect the PRN Connector that is inside the Ticket Printer and Validator Unit (BV Case B) to the Ticket Printer, and then install the Ticket Printer Unit.

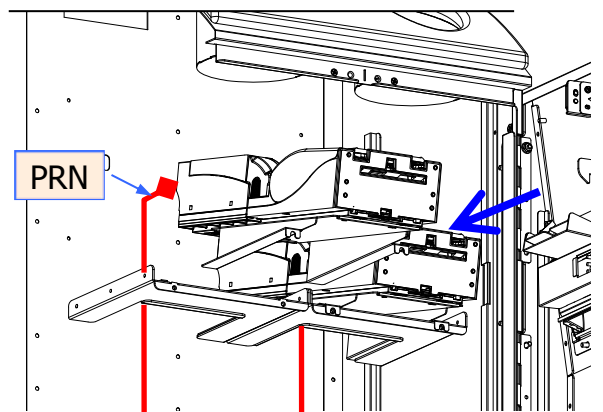
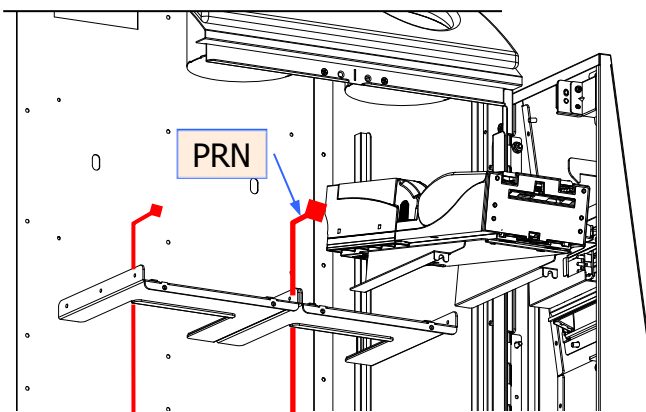

8. Affix the Ticket Printer Unit to the Ticket Printer and Validator Unit (BV Case B) by using 2 screws.

Fasteners		Qty	Appearance
F	PAN M4X8 3P	16	

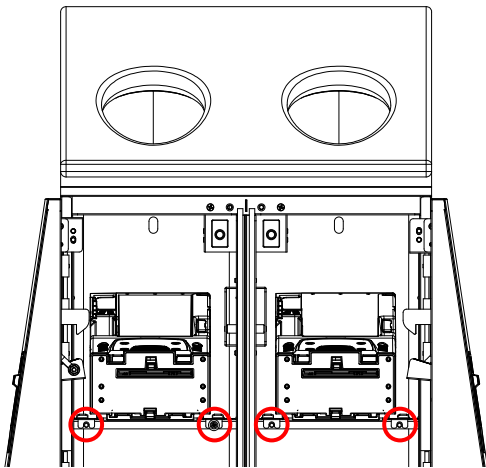

9. Prepare the following Parts.

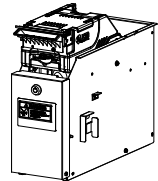
Parts Name	Qty	Appearance
Validator Unit and Accessory Cable	8	

i NOTE:

If the locks are changed for increased security, please refer to “**Key Locks**” on Chapter 3 of the SERVICE MANUAL to perform the work.

10. Connect the Accessory Cable to the Validator Unit, and thread the BR and the LX2 Connectors on the opposite side through the hole indicated below.

**CAUTION!**

The Cable connected to the Validator must pass through the hole at the back side of the Validator Unit.

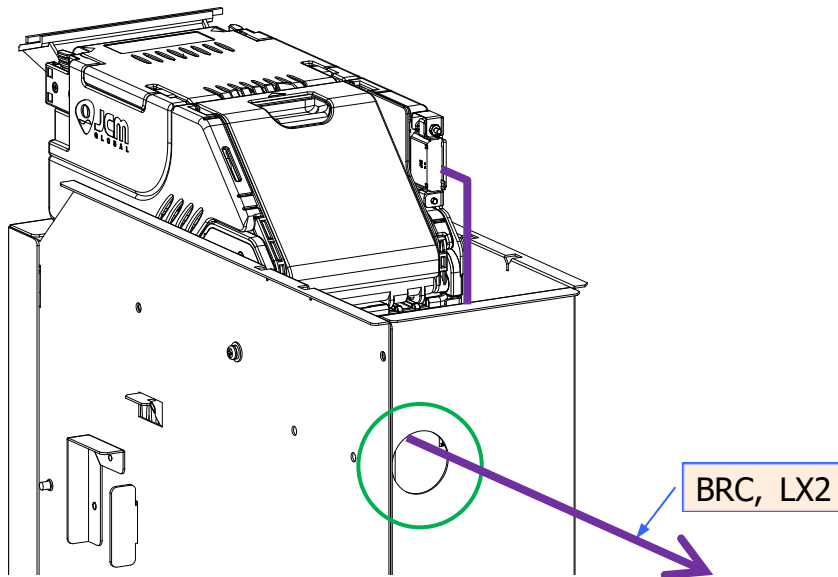

11. Connect the BR and LX2 Connectors to the BR (or BR1, BR2) and LX2 Connectors of the Center Unit.

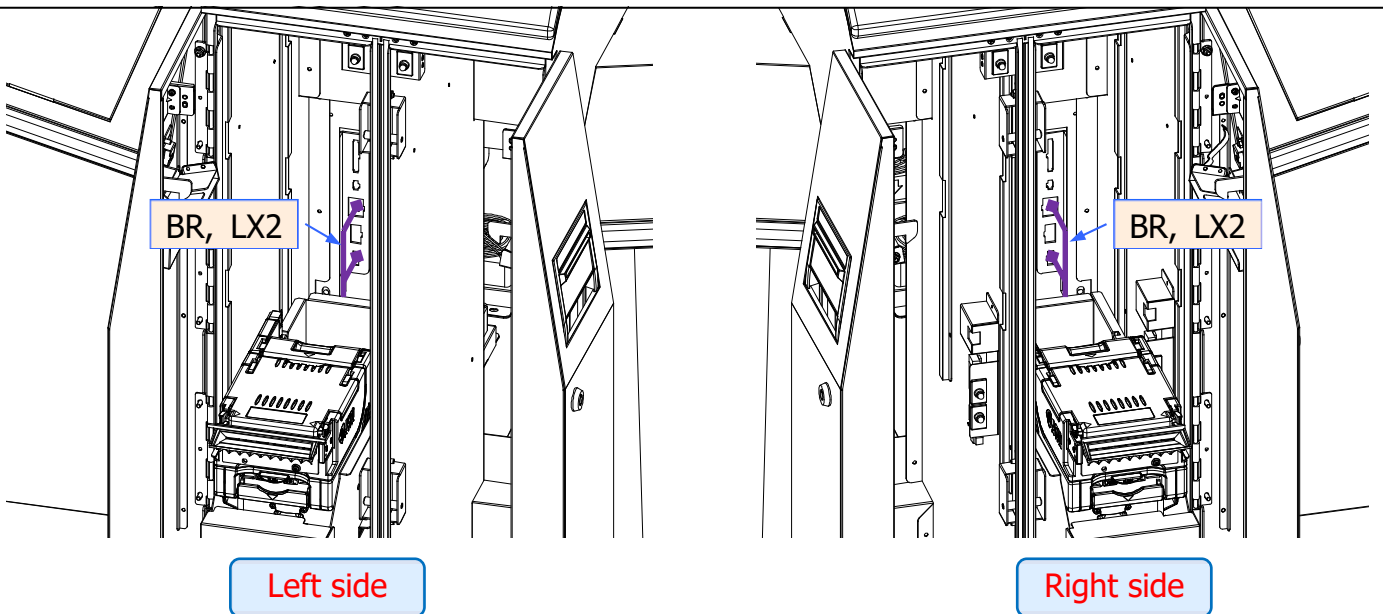

12. While paying attention not to damage any Cable, install the Validator Unit inside the Ticket Printer and Validator Unit (BV Case B).

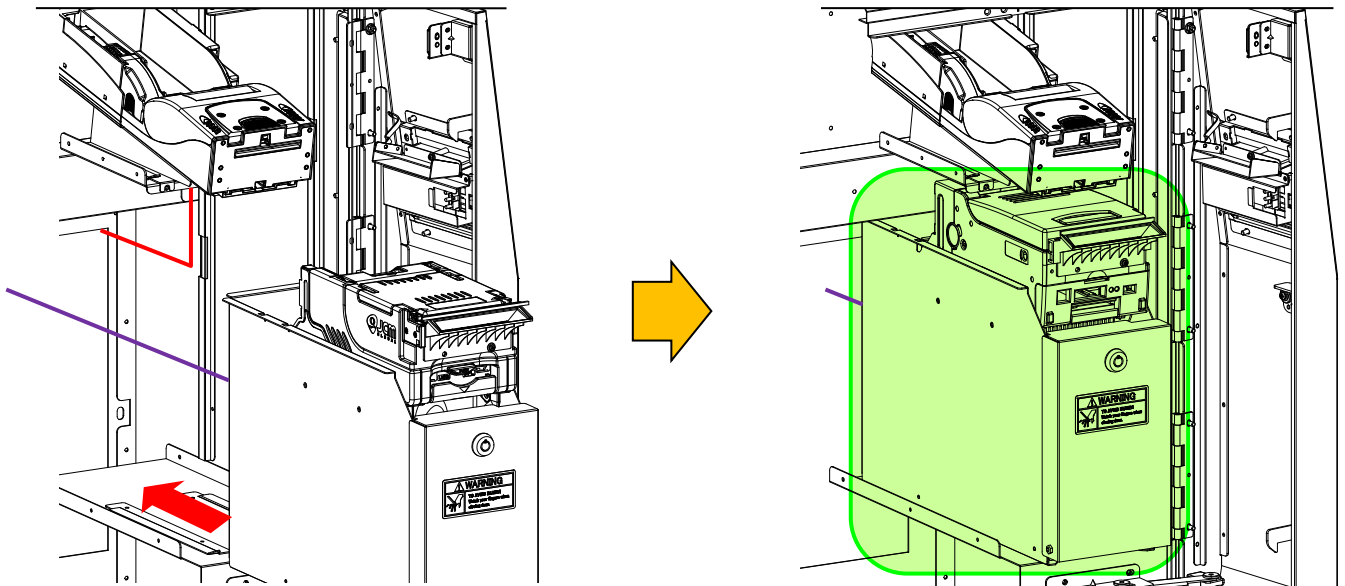

13. Draw out the Stacker from the Validator Unit, and affix the Validator Unit by using 2 screws.

Fasteners		Qty	Appearance
F	PAN M4X8 3P	16	

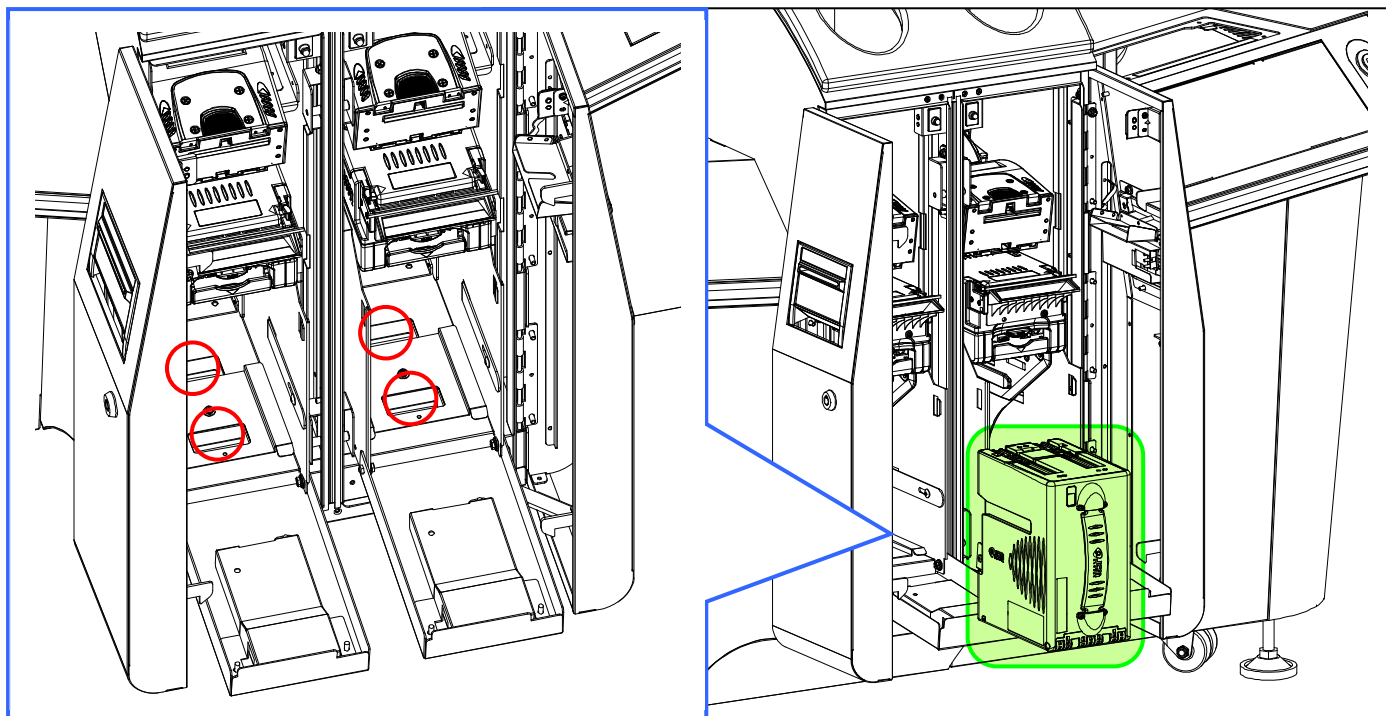

14. Return the Stacker to its position and then close the Ticket Printer Validator Unit (BV Case B).

At this point the machine should look like this.

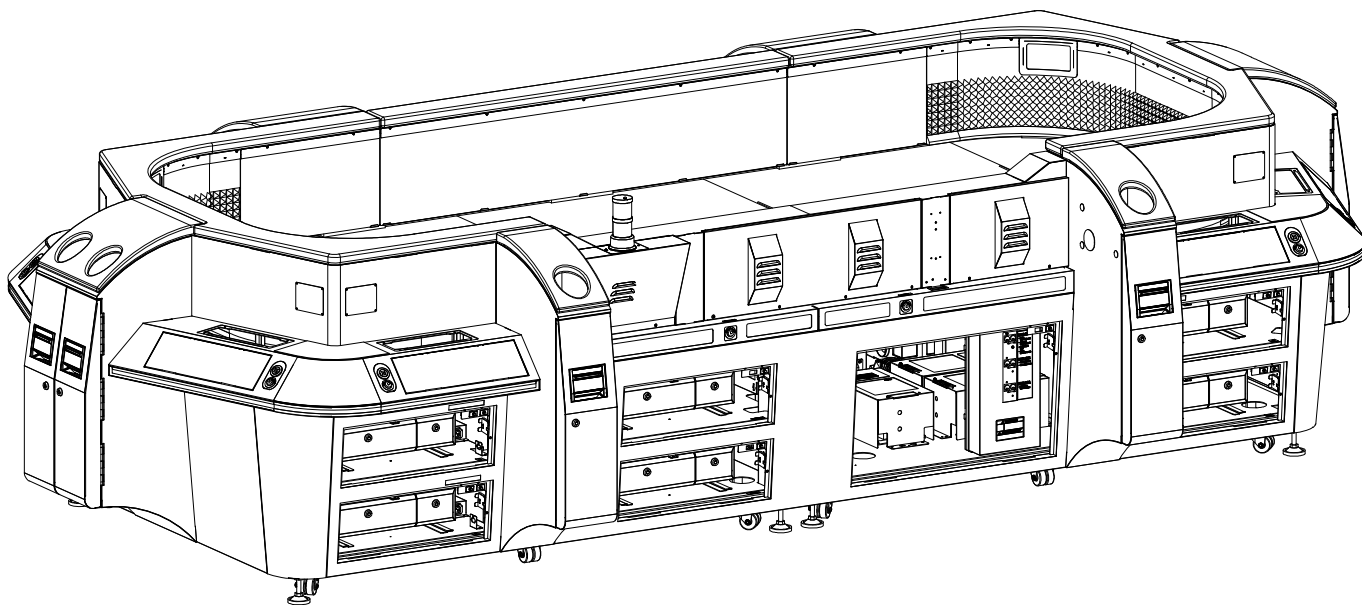

3. 2. 12: Installing the Dealer Terminal Unit

1. Prepare the following Parts.

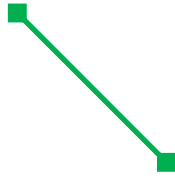
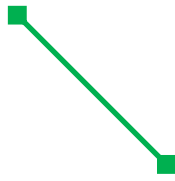
Parts Name	Qty	Appearance
Earth Cable(GST-300-R2M4)	1	
GD-200 Harness	1	

2. Affix the Earth Cable of the Shielding Cover that covers the Cable prepared at STEP 11 of 3.2.7, together with the Earth Cable(GST-300-R2M4) and the GD-200 Harness, by using a screw in the position indicated below.

Fasteners		Qty	Appearance
F	PAN M4X8 3P	1	

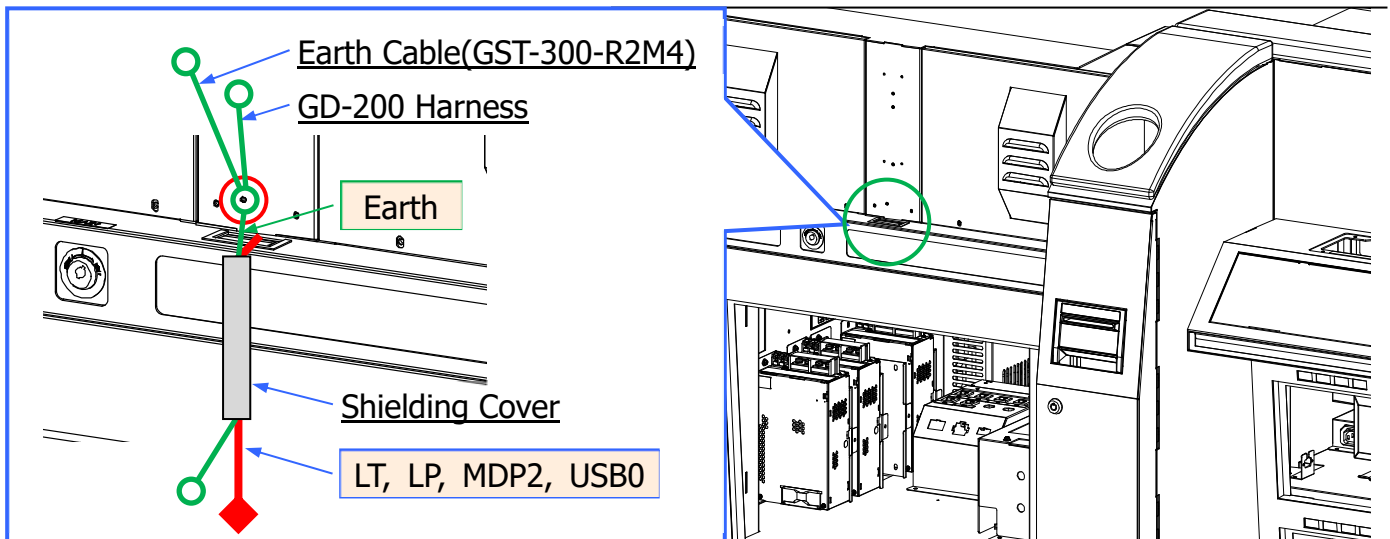

3. Prepare the following Parts.

Parts Name	Qty	Appearance
Monitor Mount Base	1	

4. Affix the Mount Monitor Base to the Center Unit by using 4 screws.

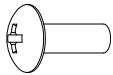
Fasteners		Qty	Appearance
Cb	TRUSS M4x12 BLK	4	

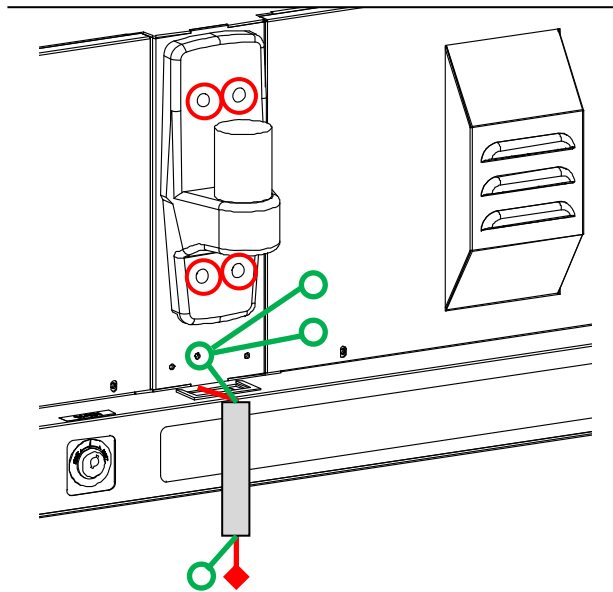
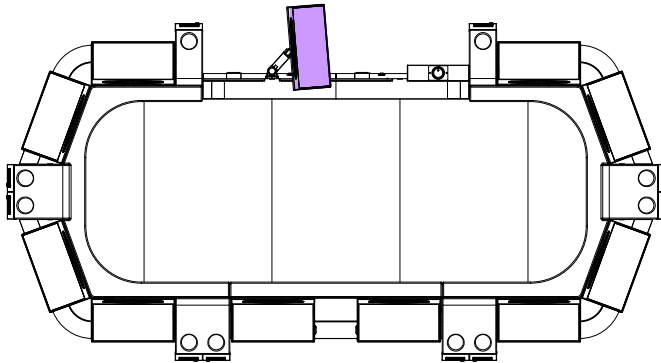

5. Prepare the following Parts.

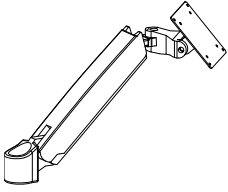
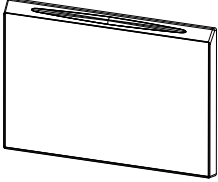
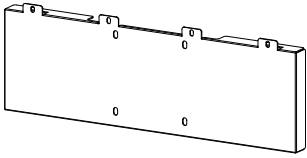
Parts Name	Qty	Appearance
Monitor Mount Arm ※ERGOTRON Accessories for fixing included. (Cap, Sleeve, M6Washer M6x45 and 4mm Tool) More details at STEP 7.	1	
Monitor(for Dealer Terminal)	1	
Monitor Mount Arm Base(DL LCD BRKT)	1	

6. Put the Monitor Mount Arm Base (DL LCD BRKT) on the back of the Monitor, and then affix over them the Monitor Mount Arm, by using 4 screws.

Fasteners		Qty	Appearance
Bb	TRUSS M4x10 BLK	4	

i NOTE:

Pay attention not to scratch the surface of the monitor during the operation.

Monitor Mount Arm Base(DL LCD BRKT)

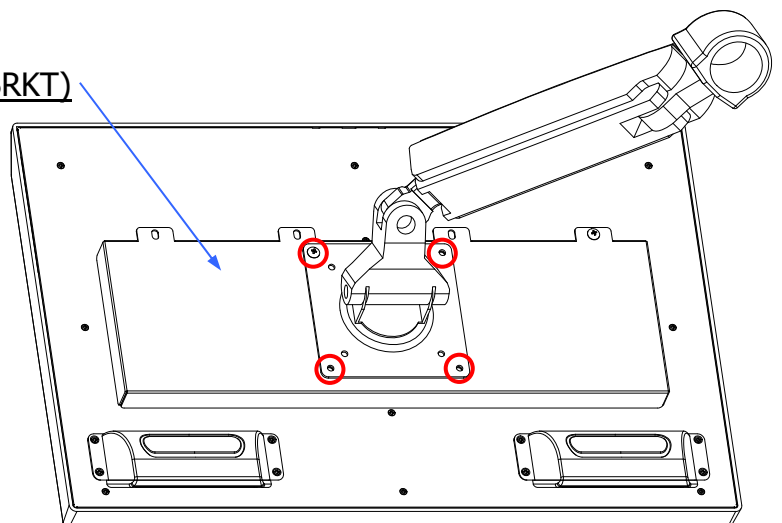

7. Stuck the Monitor Mount Arm installed on the Monitor, in the Shaft of the Monitor Mount Base.

i NOTE:

Refer to the illustration to install the Accessories included, and then affix the Monitor Mount Arm to the Monitor Mount Base.

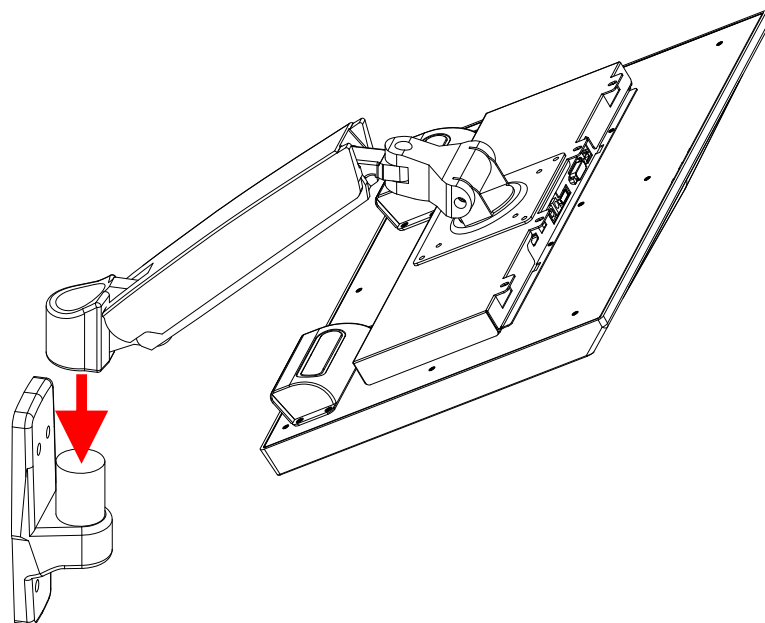
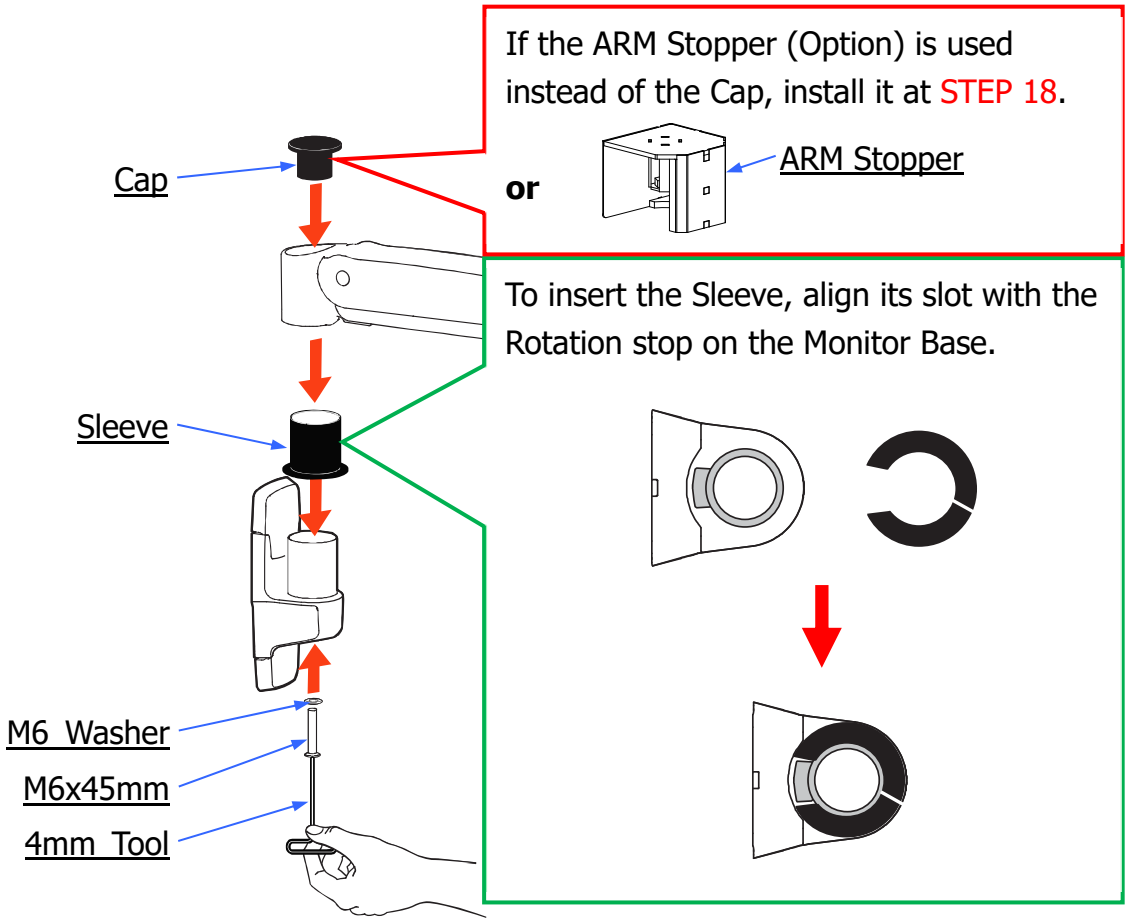

8. Affix the Earth Cable(GST-300-R2M4) that was fixed at STEP 2, to the back side of the Monitor Mount Arm.

Fasteners		Qty	Appearance
F	PAN M4X8 3P	1	

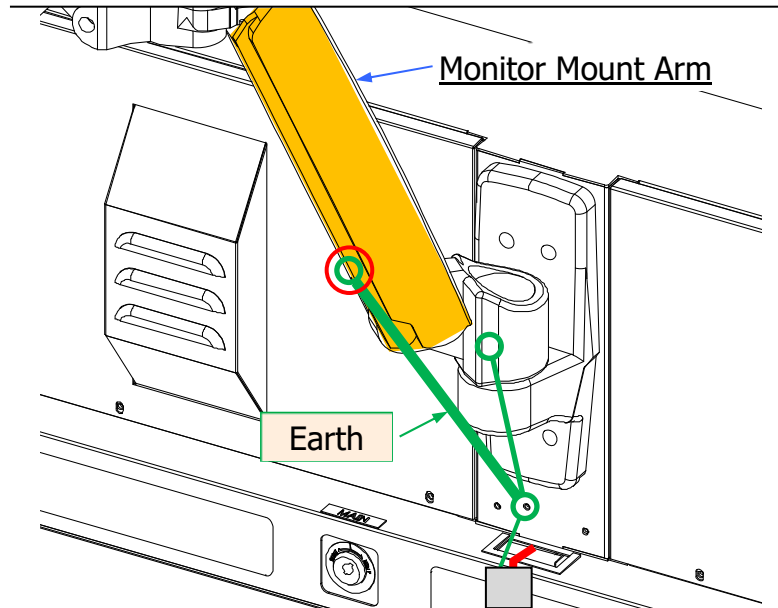

9. Affix the GD-200 Harness that was fixed at STEP 2, to the back of the root part of the Monitor Mount Arm.

Fasteners		Qty	Appearance
F	PAN M4X8 3P	1	

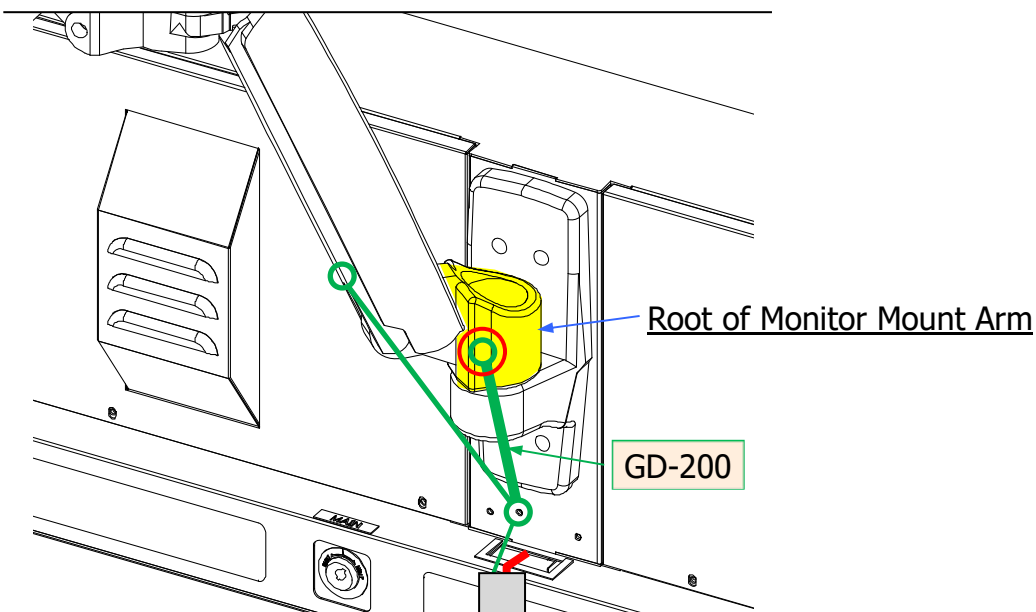

10. Prepare the following Parts.

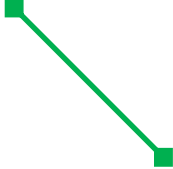
Parts Name	Qty	Appearance
GD-200 Harness	1	

11. Affix with screws the GD-200 Harness to the back side and the top part of the Monitor Mount Arm.

Fasteners		Qty	Appearance
F	PAN M4X8 3P	2	

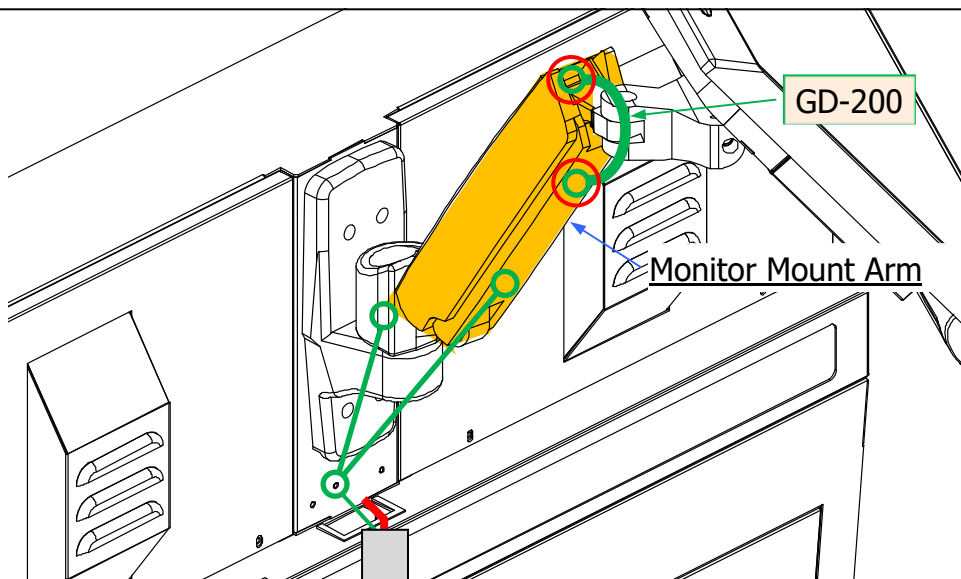

12. Connect the LT, LP, MDP2 and USB0 Connectors that were prepared at STEP 11 of 3.2.7, to the Connectors of the Monitor.

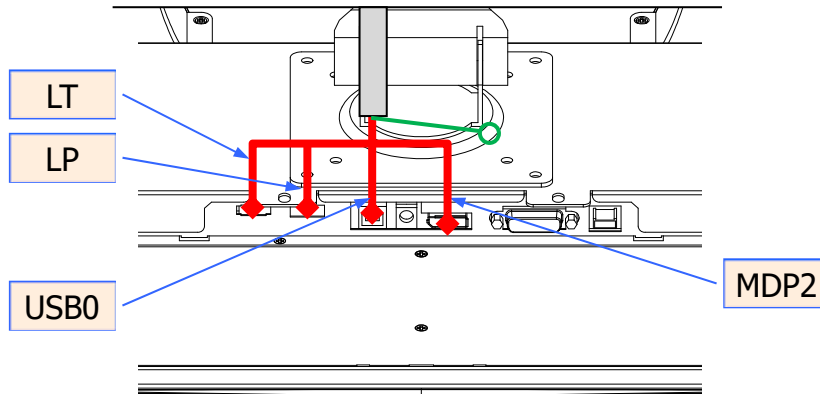

13. Remove the flat head screw from the position illustrated below, and affix the Earth Cable by using the substitute screw.

Fasteners		Qty	Appearance
U	PAN M3X6 3P	1	

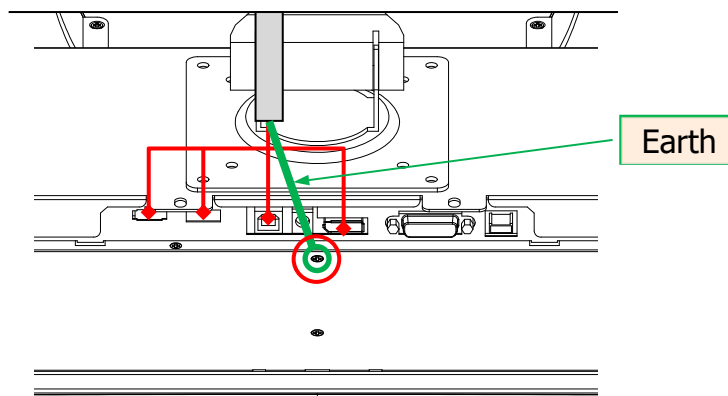

14. Prepare the following Parts.

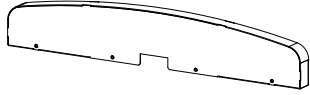
Parts Name	Qty	Appearance
Monitor Connector Cover(DL LCD Cover)	1	

15. Install The Monitor Connector Cover (DL LCD Cover) to the Monitor so that it encloses the Shielding Cover of the Cable, and affix it with 4 screws.

Fasteners	Qty	Appearance
Ab TRUSS M4x8 BLK	4	



CAUTION!

There is a possibility to damage the Connector that is connected to the Monitor, if the Dealer Terminal is bent forward too much.

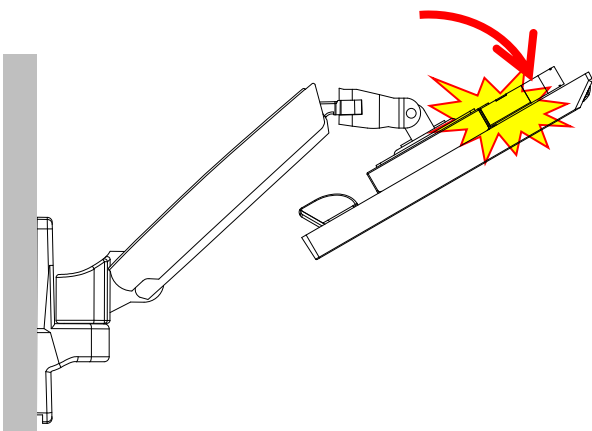

Monitor Connector Cover(DL LCD Cover)

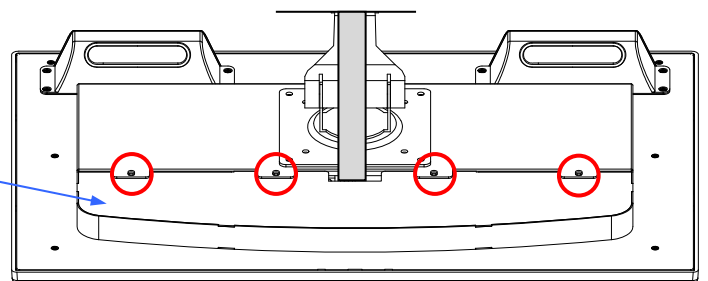

16. Prepare the following Parts.

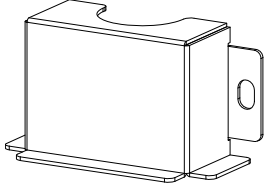
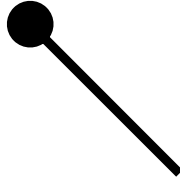
Parts Name	Qty	Appearance
Cable Cover(DL Harness BRKT)	1	
Nylon Cable Tie ※ERGOTRON Accessories	2	

17. Affix the Cable Cover (DL Harness BRKT) to the Center Unit so that it encloses the Shielding Cover of the Cable, and affix it with 2 screws. Then affix the Cable to the Monitor Mount Arm with 2 Nylon Cable Ties.

Fasteners		Qty	Appearance
Ab	TRUSS M4x8 BLK	2	

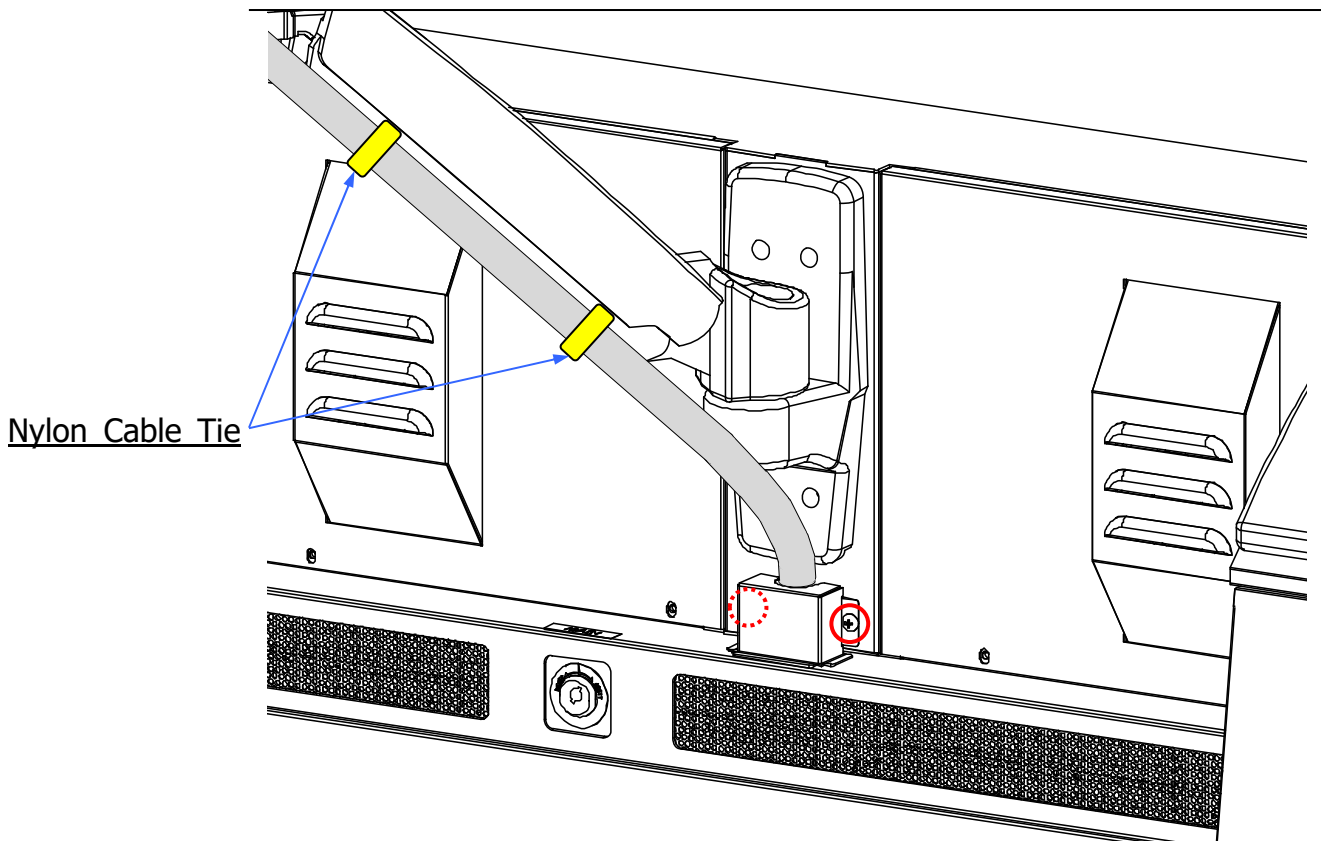

18. Prepare the following Parts.

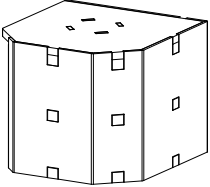
Parts Name	Qty	Appearance
Arm Stopper(Optional) ※Can be installed instead of the CAP(Refer to STEP 7)	1	

At this point the machine should look like this.

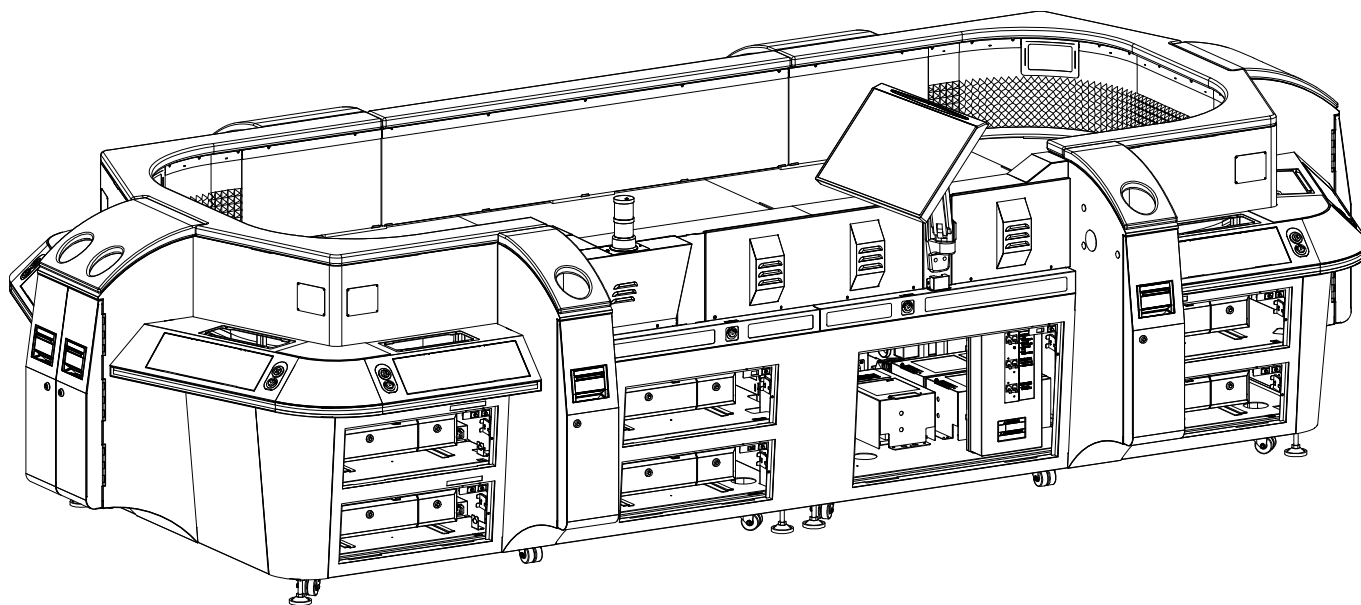

3. 2. 13: Preparing the Player Terminal Unit

1. Prepare the following Parts.

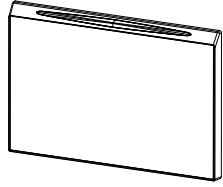
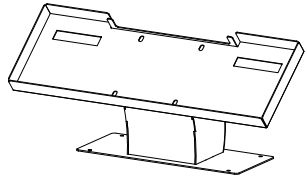
Parts Name	Qty	Appearance
Monitor(for Player Terminal)	10	
Monitor Stand(LCD BRKT)	10	

2. Affix the Monitor Stand (LCD BRKT) to the Monitor by using 4 screws.

Fasteners		Qty	Appearance
F	PAN M4X8 3P	40	

i NOTE:

Pay attention not to scratch the surface of the monitor during the operation.

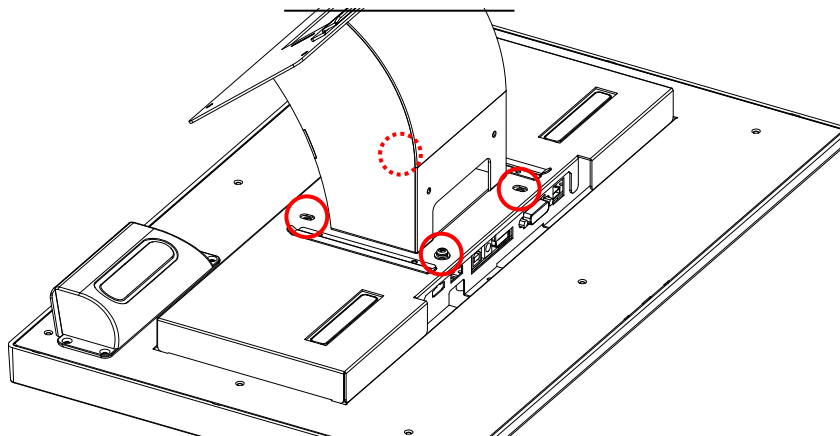

3. Prepare the following Parts.

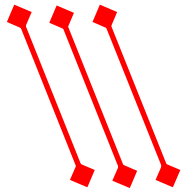
Parts Name	Qty	Appearance
<ul style="list-style-type: none"> · TPRC LCD ST Harness · G USB(1.5m) Harness · DP Cable(2.0m KS10007-20E) 	10 for each	

4. Lead the TPRC LCD Harness, the G USB Harness and the DP Cable inside the Monitor Stand (LCD BRKT) as illustrated below, and connect the LT, LP, DP and USB-B Connectors to the connector of the Monitor.

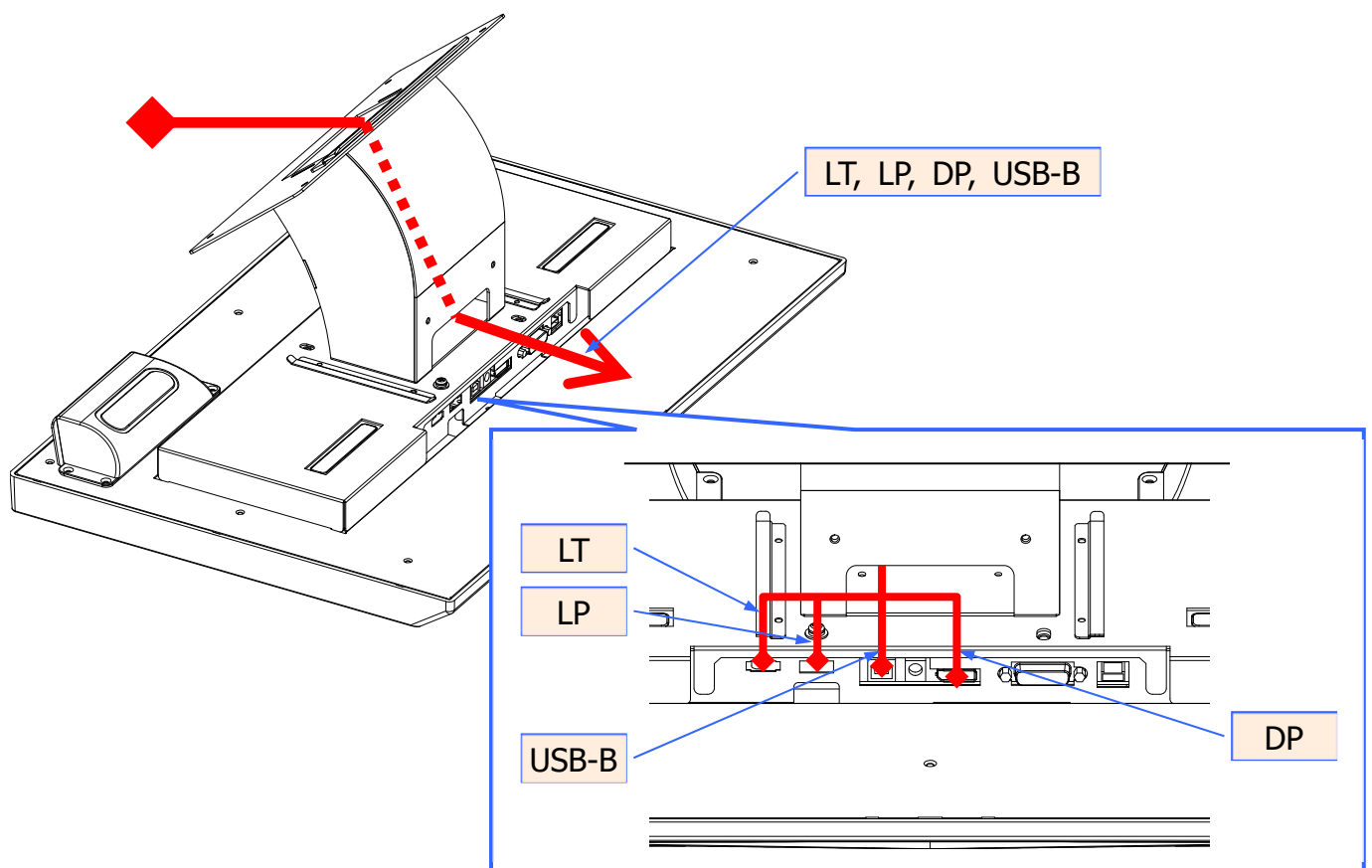

5. Prepare the following Parts.

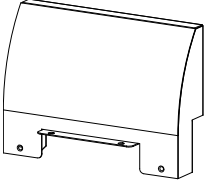
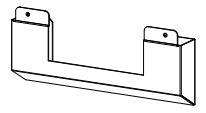
Parts Name	Qty	Appearance
Monitor Stand Cover A(LCD Cover A)	10	
Monitor Stand Cover B(LCD Cover B)	10	

6. While paying attention to the Connectors and Cables, stuck the Monitor Stand Cover A (LCD Cover A) and the Monitor Stand Cover B (LCD Cover B) on the Monitor Stand (LCD BRKT), and affix them by using 4 screws. Arrange the opposite ends so that they will not interfere with the next operations.

Fasteners		Qty	Appearance
Ab	TRUSS M4x8 BLK	40	

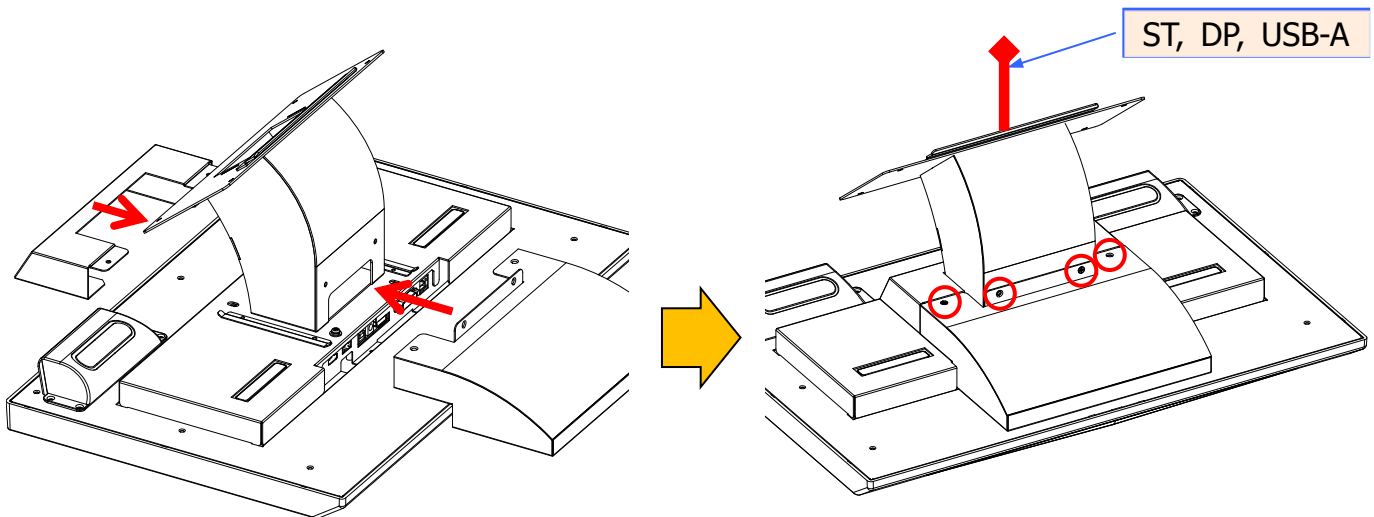

3. 2. 14: Installing the Player Terminal Unit

1. Prepare the following Parts.

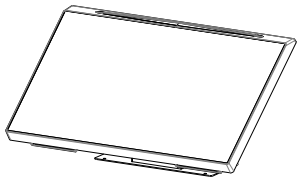
Parts Name	Qty	Appearance
Player Terminal Unit (Assembled in 3.2.13)	10	

2. Locate the connectors inside each opening of the Wall Unit, and connect the ST, DP and USB-A Connectors of each Player Terminal, by referring to the chart below. While paying attention not to pinch any Cable, install the Player Terminal Units by hanging the Hooks on the back side.

CAUTION!

The Player Terminal Unit is not fixed yet. Keep holding with your hands the Player Terminal Unit, from the start of the procedure until it is completely fixed.

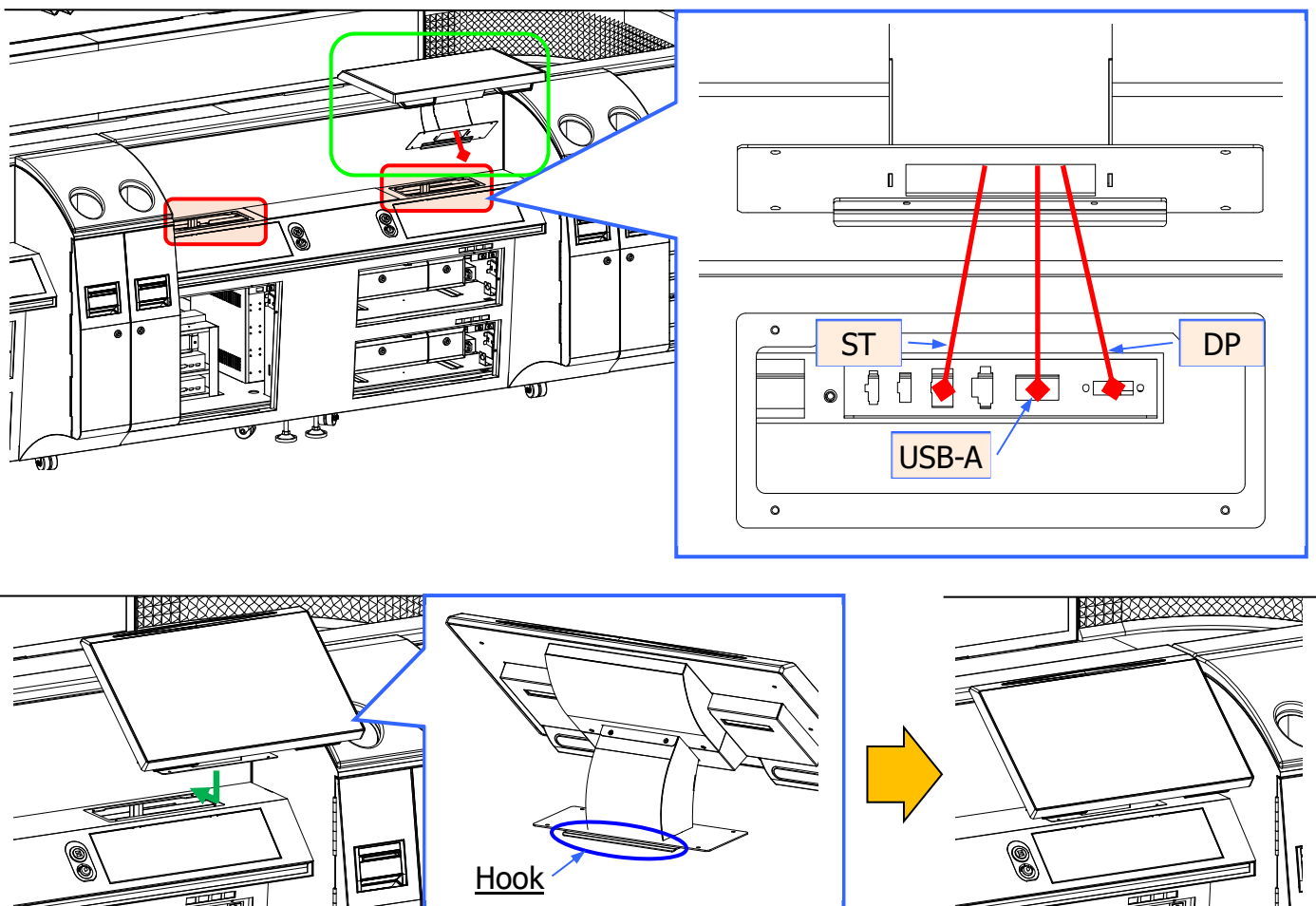

3. Affix each Player Terminal Unit to the Center Unit by using 40 screws.

Fasteners		Qty	Appearance
Vb	HEXALOBULAR INTERNAL M4x8 BLK (Torx)	40	

i NOTE:

It is necessary a specific Torx screwdriver (T15) for the HEXALOBULAR INTERNAL M4x8 BLK(Torx)

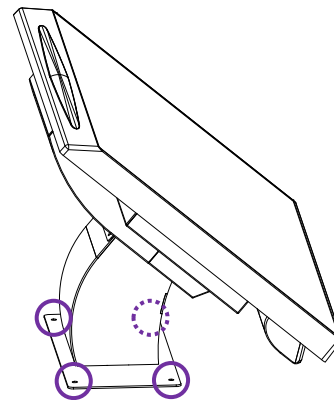
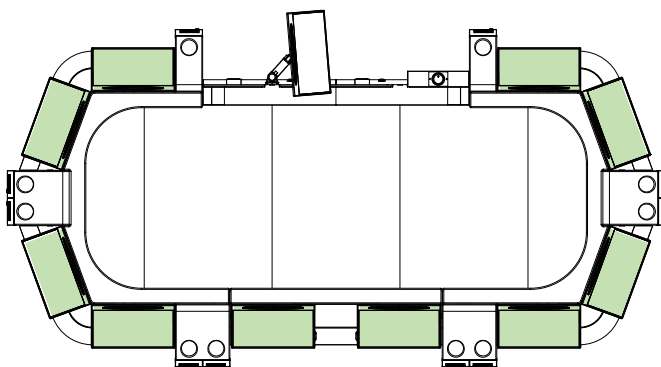

4. Put a Level Gauge on each direction and at the center of the Field, and calibrate the adjuster so that the field is perfectly horizontal.



At this point the machine should look like this.

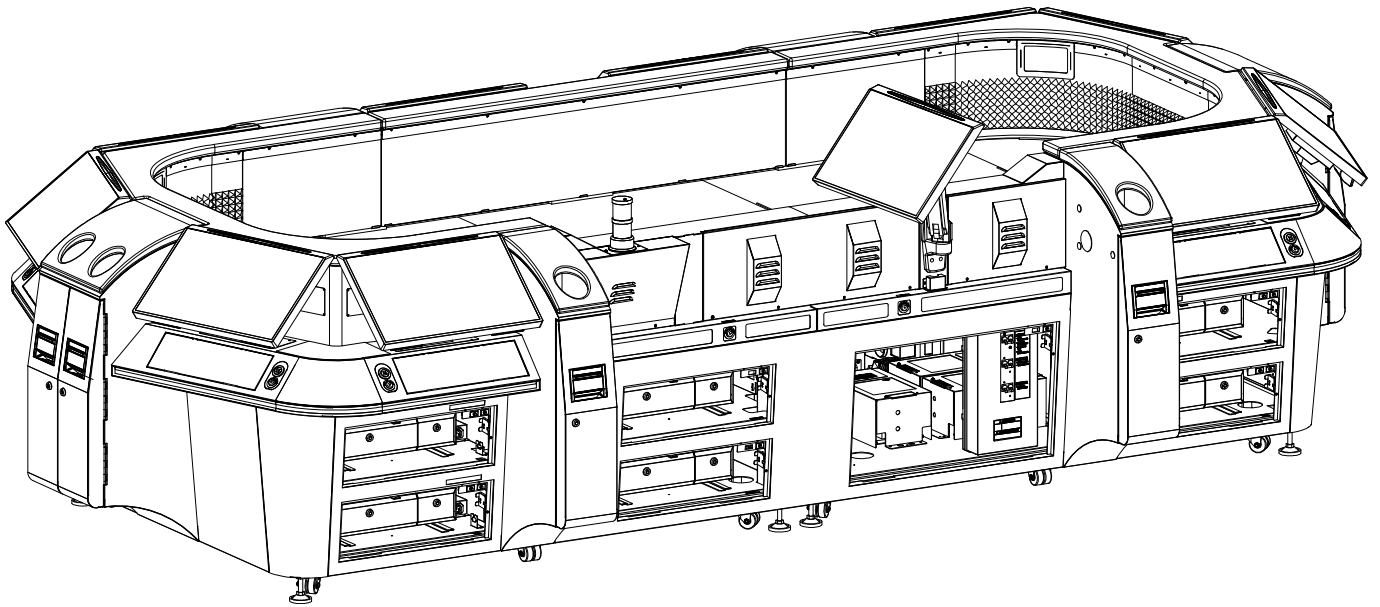

3. 2. 15: Connecting the Center Unit to the Power Source

1. Remove one nut to the Switch Box to detach the Switch Cover, and locate the Terminal Block.

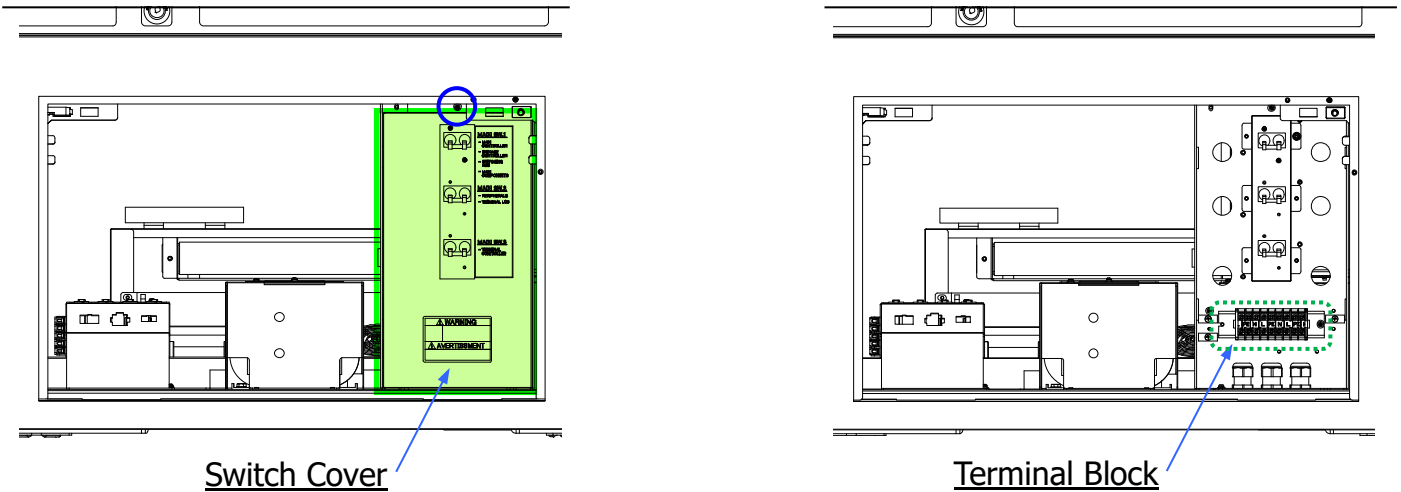

2. Insert your prepared three 3Core, 2.0Sq Cabtyre Power Cables inside the Center unit from the bottom. Then secure the power cable by turning the bush and install a 4mm diameter Solderless Terminal conform to the Power Cable.

⚠ DANGER!

Risk of Electric Shock.

- The procedure for the connection to the Terminal Block can be performed only by electrical contractors or by qualified electricians.
- Before connecting power line, make sure to check that the power is OFF.

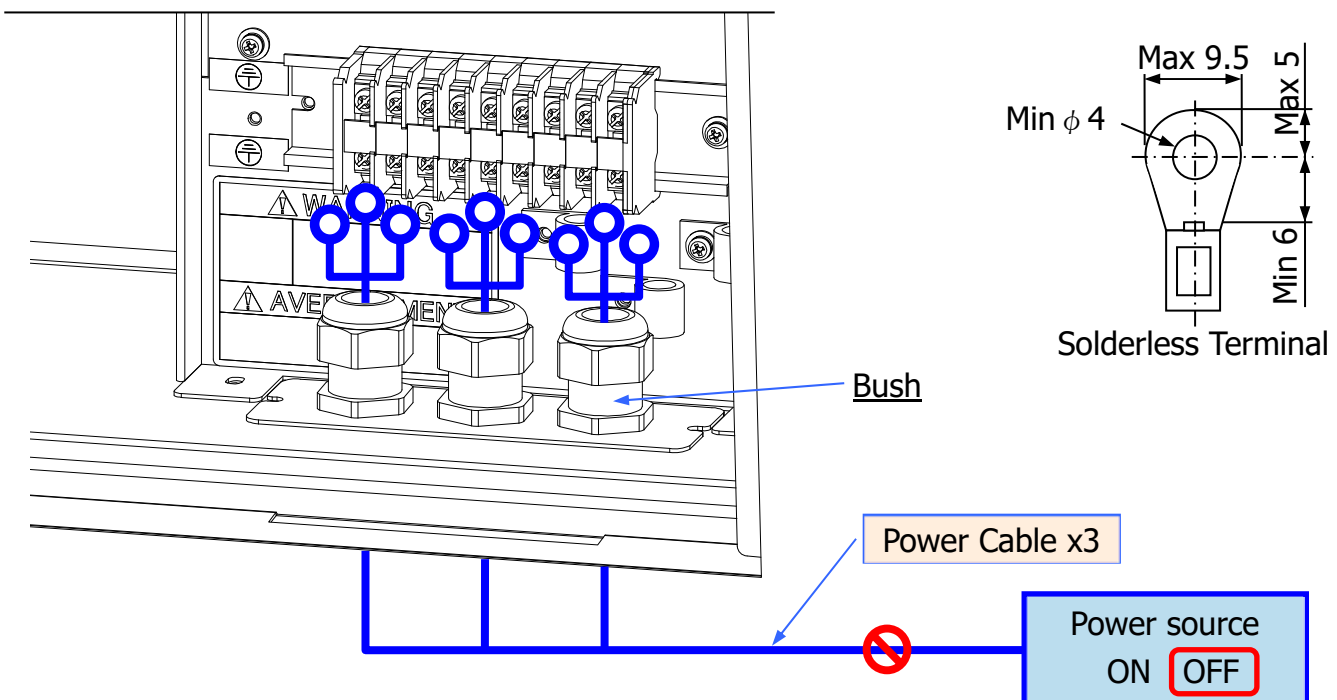

3. Connect the power cable to the terminal block as depicted below.

Description of terminal notation
L : Live
PE : Protective Earth
N : Neutral

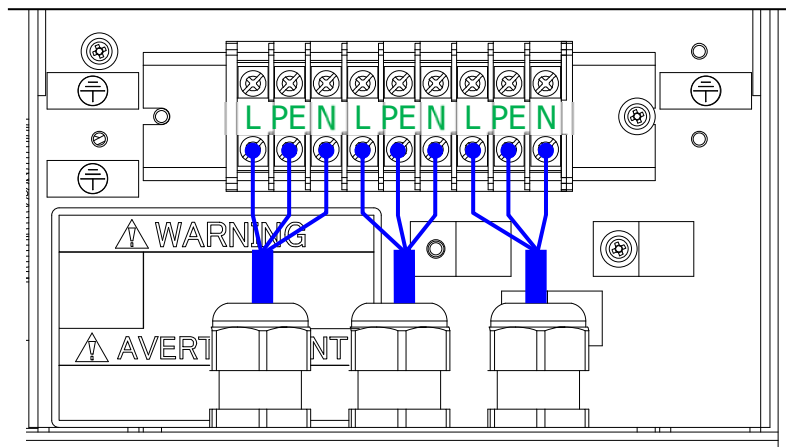

4. Return the Switch Cover.

3. 2. 16: Installing the History Display Unit(Optional)

i NOTE: Option-3

In case it was chosen the Option to add an History Display Unit, from this point refer to the procedures indicated as **Option-3**. If this Option was not chosen, continue from 3.2.17.

Option-3

1. Prepare the following Parts.

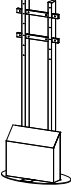
Parts Name	Qty	Appearance
Display Stand Unit	1	

2. According to the chosen layout, place the Display Stand Unit at your desired position on a flat floor, and untie the Cables arranged in the Display Stand Unit.

i NOTE:

- Please take all the precautions needed to prevent the History Display Unit from falling.
- The History Display Unit is connected through the supplied cable (around 3m). Please consider this when planning the layout of the machine.

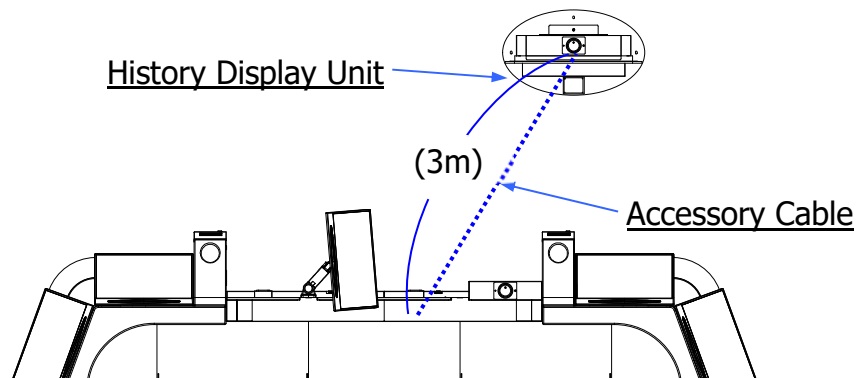

3. Prepare the following Parts.

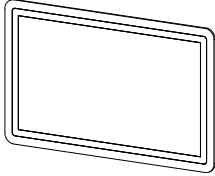
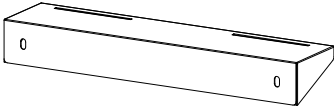
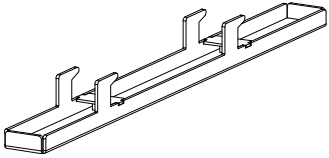
Parts Name	Qty	Appearance
History Display Unit	1	
Top Cover Support BRKT	1	
History Display BRKT ※If it is fixed to the Display Stand Unit, detach it.	2	

4. Affix the Top Cover Support BRKT and History Display BRKT to the History Display Unit, by using 2 bolts.

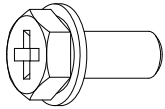
Fasteners		Qty	Appearance
X	HEX UPSET M6 x 15 3P	6	

i NOTE:

- Install the History Display Unit paying attention to the upside/downside orientation.
- According to where the History Display BRKT is affixed, it is possible to set the History Display Unit to 3 different heights.

TOP

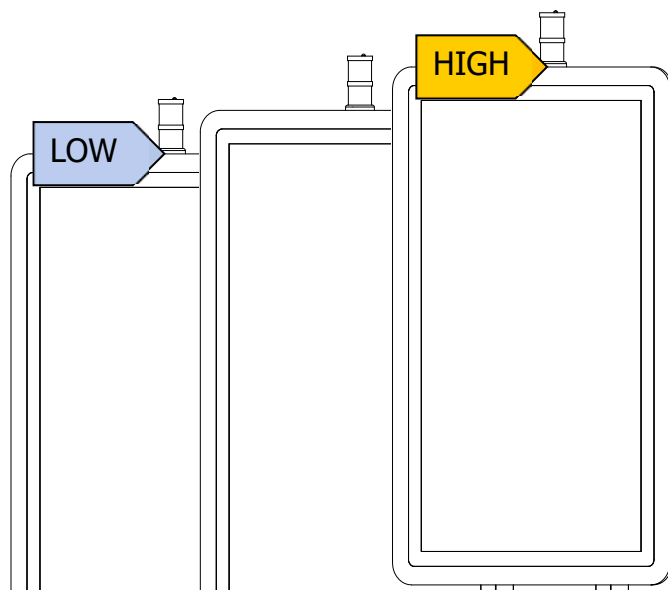
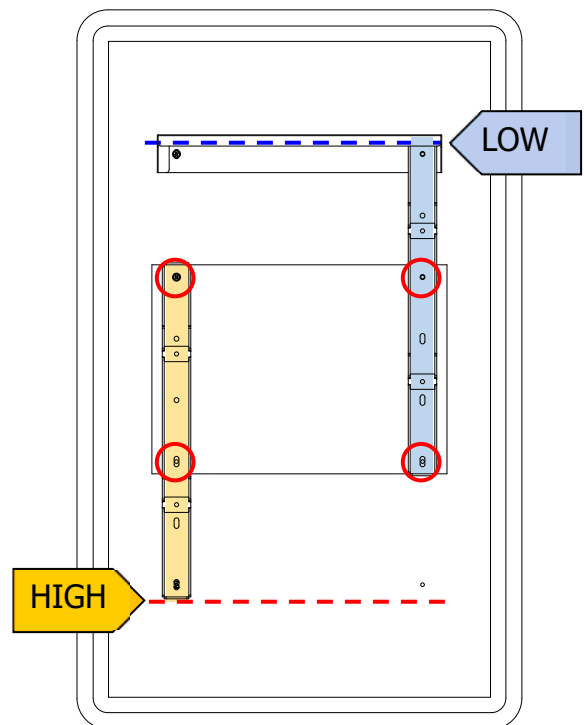
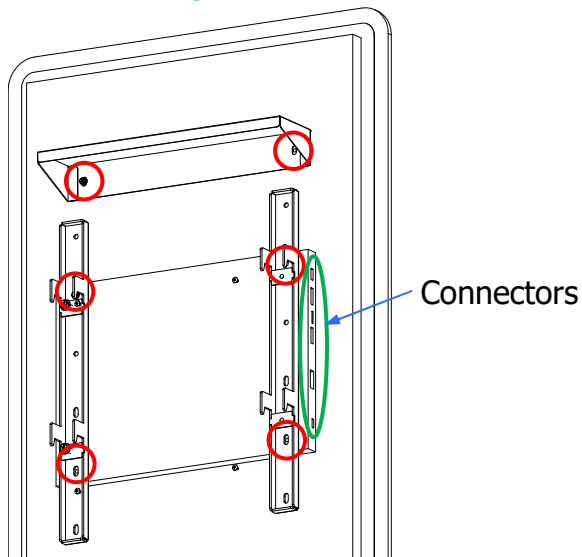

5. Hang the History Display Unit to the Display Stand Unit, and affix it by using 4 bolts.

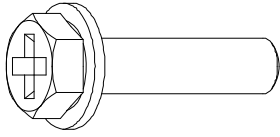
Fasteners		Qty	Appearance
Y	HEX UPSET M8 x 35 3P	4	

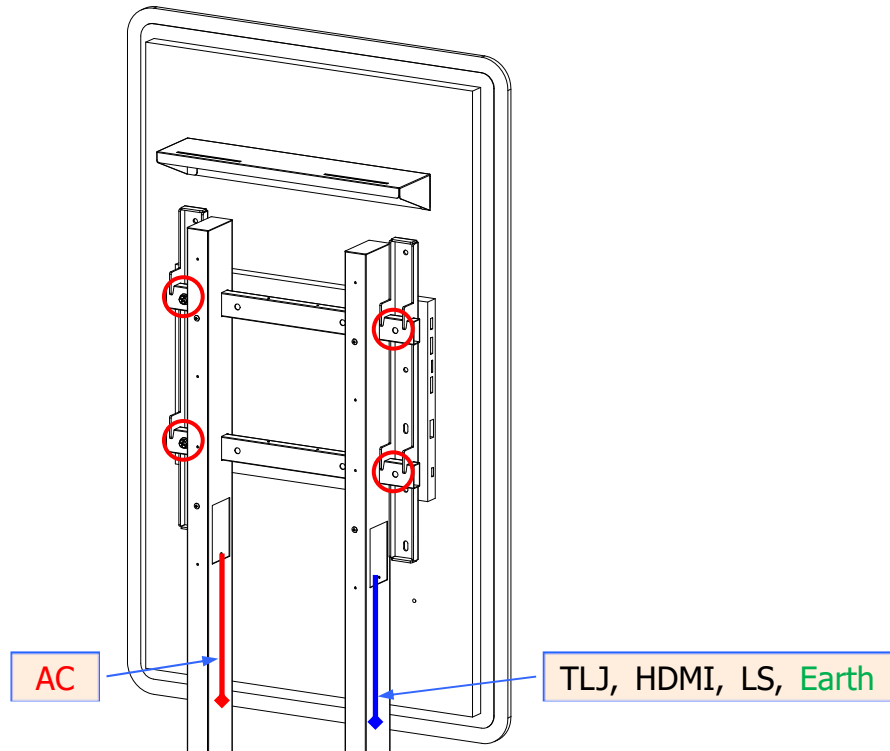

6. Connect the HDMI and LS Connectors of the Display Stand Unit to the Connectors of the History Display Unit.

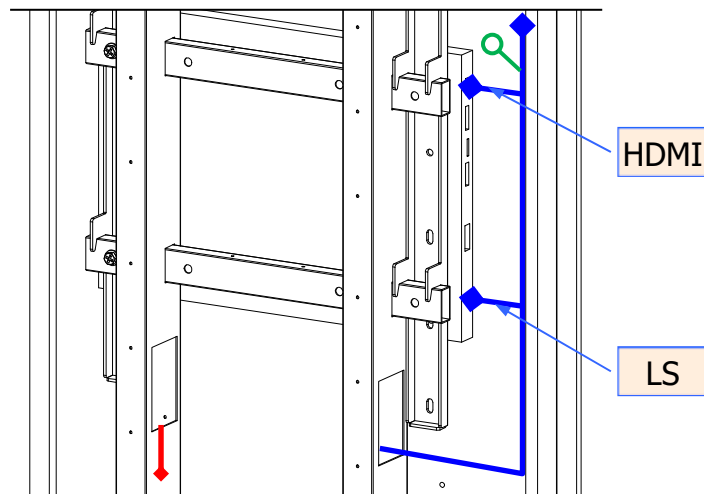

7. Affix with a screw the Earth Cable to the Top Cover Support BRKT of the History Display Unit.

Fasteners		Qty	Appearance
F	PAN M4X8 3P	1	

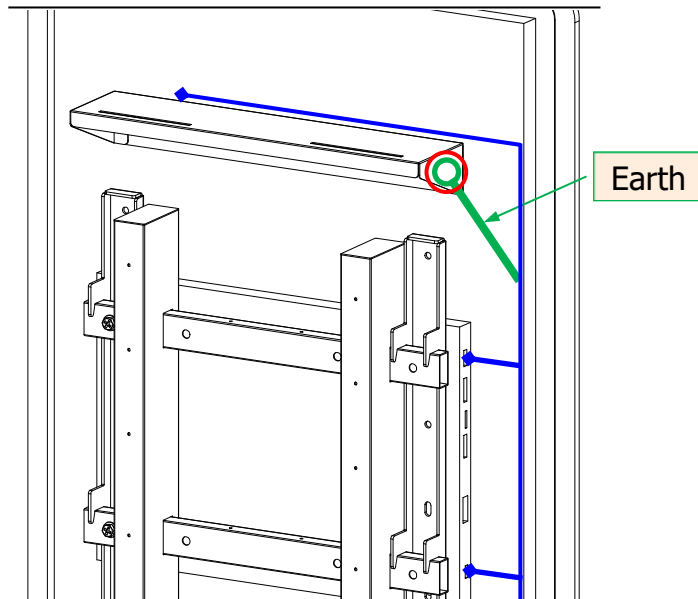

8. Prepare the following Parts.

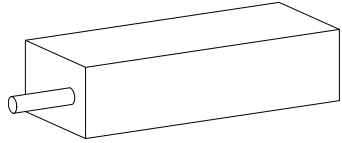
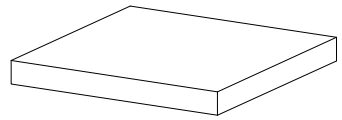
Parts Name	Qty	Appearance
Switching Power Adapter	1	
Ring Fix Tape	8	

9. Attach the Ring Fix Tape on the Switching Power Adapter and on the Display Stand Unit, and install the Switching Power Adapter in the position indicated by the illustration below.

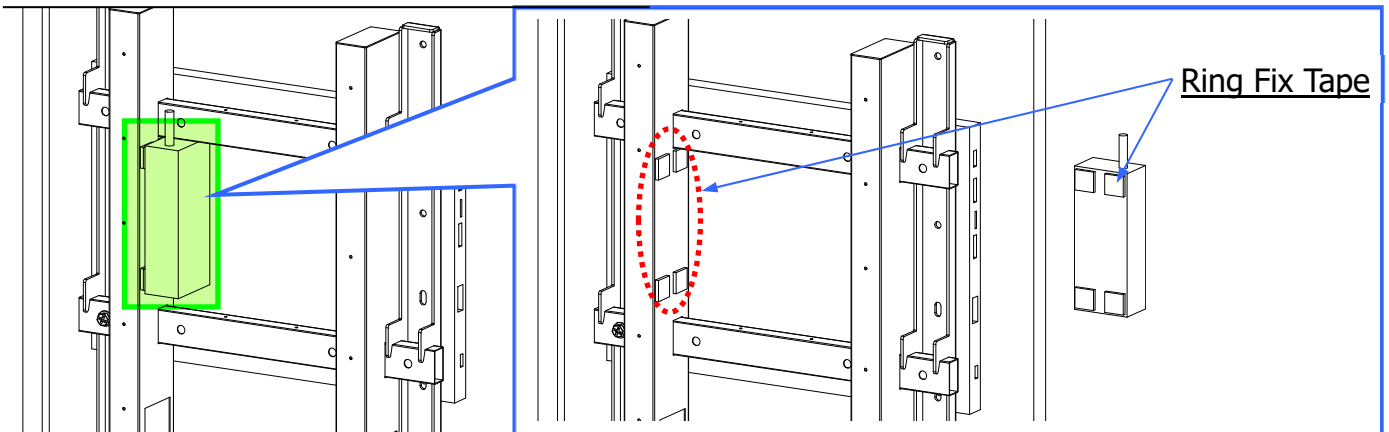

10. Connect the Switching Power Adapter to the AC Plug of the Display Stand Unit, then connect the DC Cable of the Switching Power Adapter to the DC Connector of the History Display Unit.

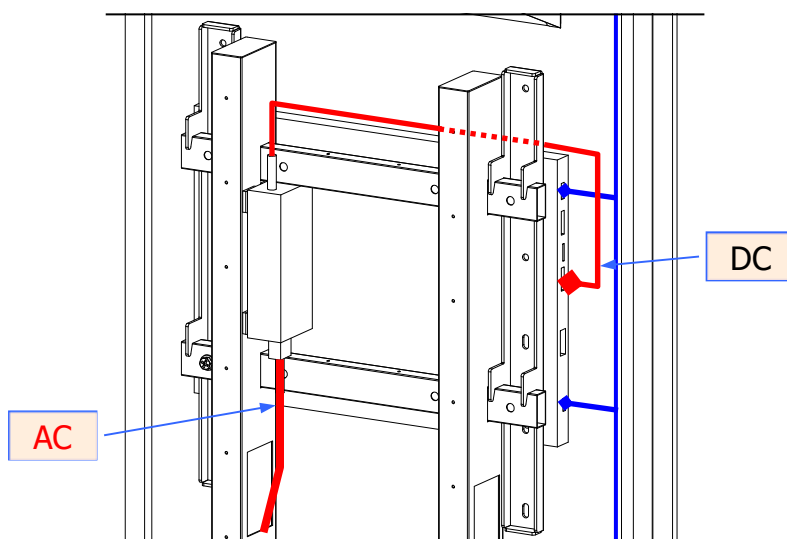

11. Prepare the following Parts.

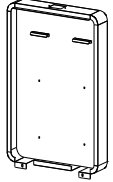
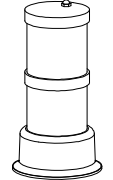
Parts Name	Qty	Appearance
History Display Top Cover Unit	1	
Tower Light(OPTION)	1	

i NOTE:

In case it was chosen to install the Tower Light on the Wall of the Center Unit as **Option-1**(refer to 3.2.8), there is no other installation of the Tower Light. Please continue from **STEP 16**.

12. Remove the 2 screws of the History Display Top Cover Unit, then detach the Tower Light BRKT that is affixed to the upper side of the History Display Top Cover Unit.

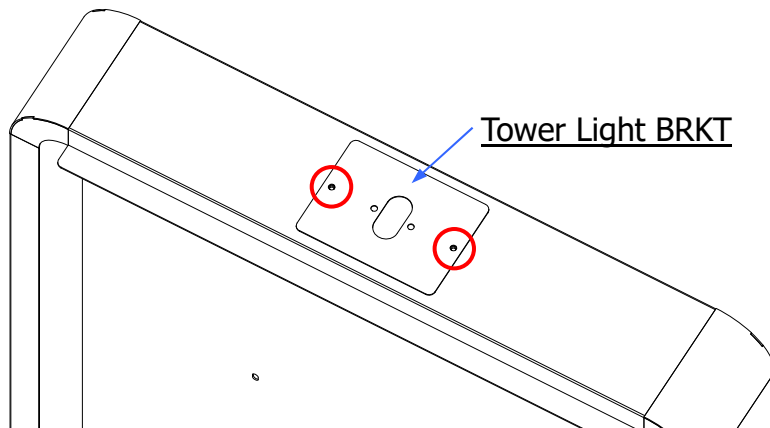

13. Thread the Tower Light harness through the hole on the Tower Light BRKT, and then affix the Tower Light by using the 2 screws (UNC#8-32-X5/8) that are located on the Tower Light.
14. Affix the earth cable terminal lug on the stud located on the backside of the Tower Light BRKT by using the nut (M4 flange).

Fasteners		Qty	Appearance
R	FLANGE NUT M4	1	

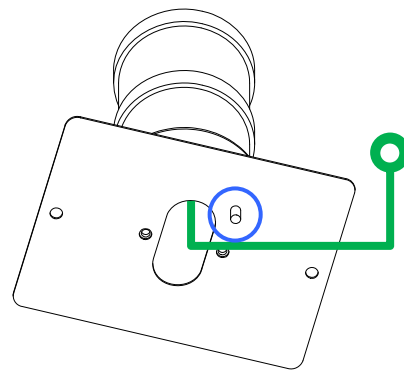
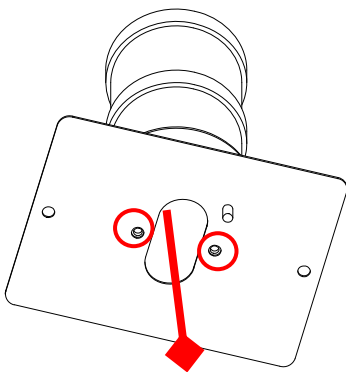

15. Fix the Tower Light BRKT on to the Topper by 2 screws, or using the screws previously removed.

Fasteners		Qty	Appearance
Bb	TRUSS M4x8 BLK	2	

i NOTE:

Make sure that the screw nut on the top of the Tower Light is located on the backside.

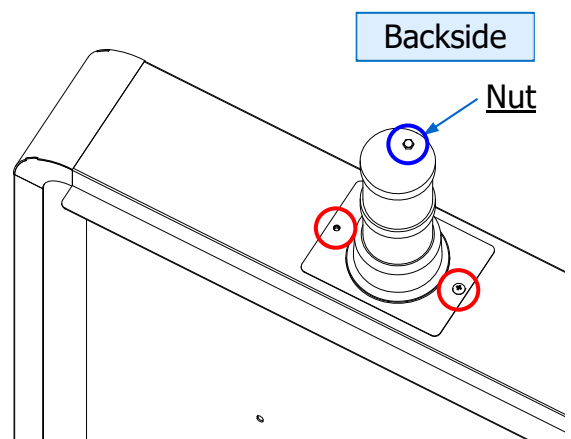
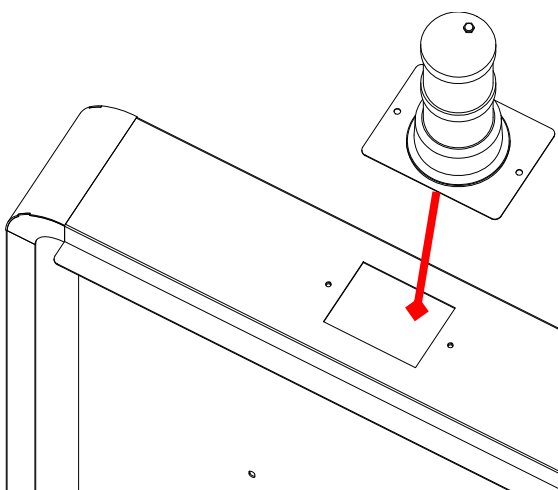

16. Check that the Switch of the History Display Unit is turned on ON. While paying attention to the Cables and Connectors, hang the Hook of the History Display Top Cover Unit to the Display Stand Unit, and affix them by using 4 screws and 2 bolts. (If a Tower Light was installed at STEP 12-15, before installing the History Display Top Cover Unit, connect the Light Tower Connector to the TLJ Connector of the Display Stand Unit.)

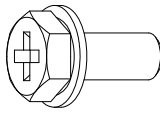
Fasteners		Qty	Appearance
Ab	TRUSS M4x8 BLK	4	
Wb	HEX UPSET M6 x 14 3P BLK	2	



CAUTION!

Please leave these switches on ON and do not change their status.

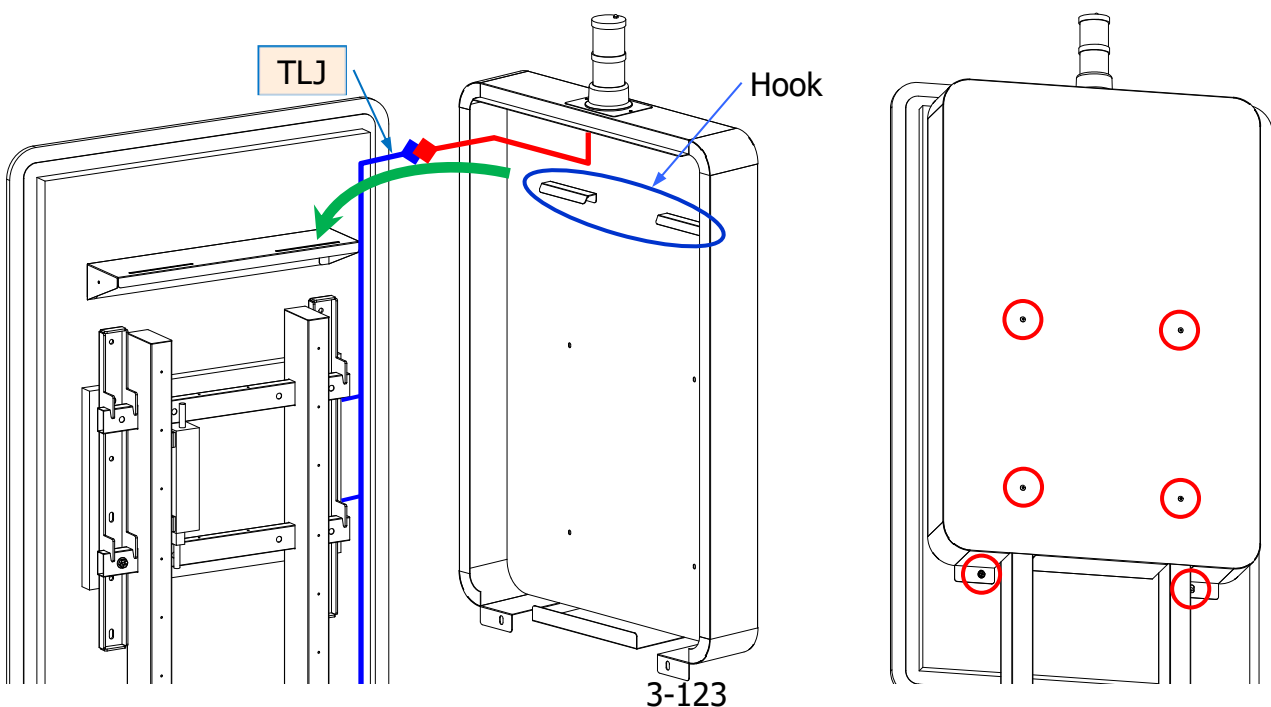
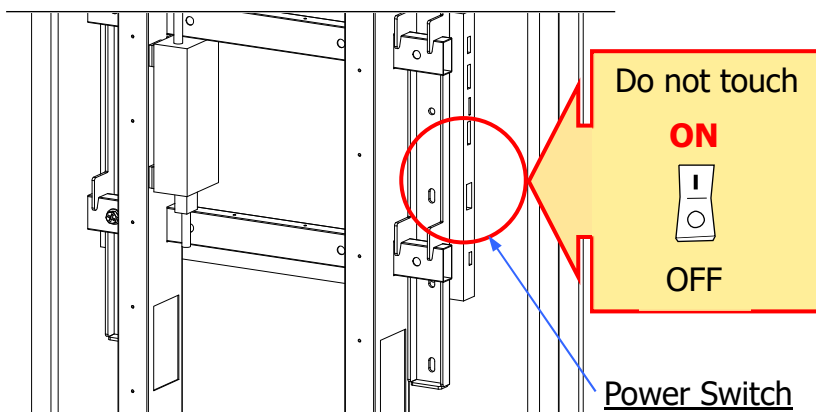

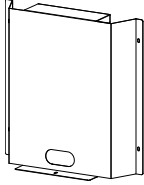

17. Prepare the following Parts.

Parts Name	Qty	Appearance
History Display Bottom Cover(Cover A)	1	

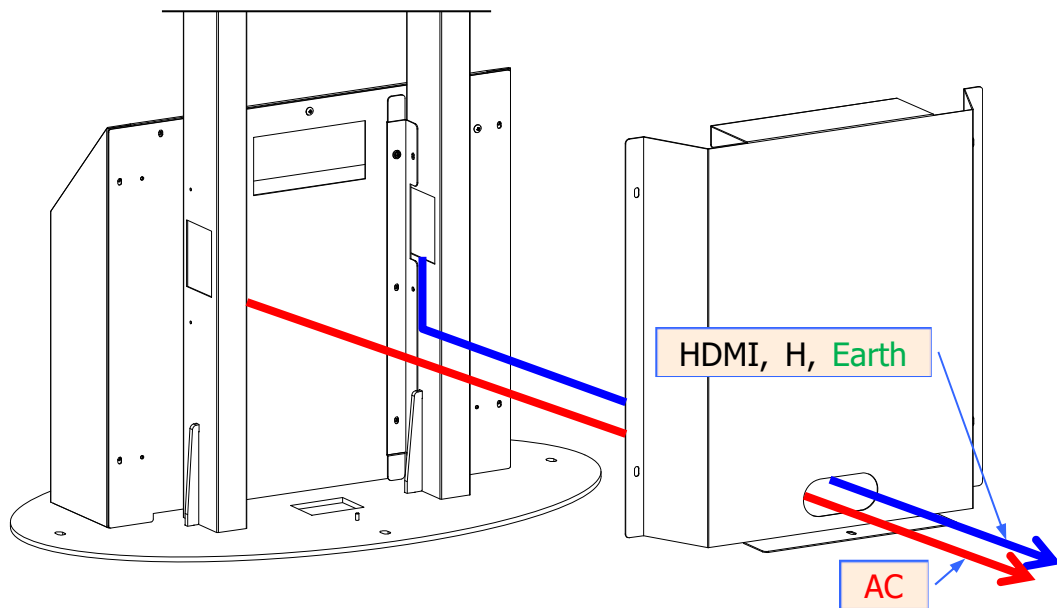
18. Pull the AC Cable of the Display Stand Unit together with the HDMI, H Connector and the Earth Cable, out of the hole of the Display Bottom Cover (Cover A).

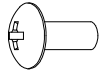

19. Pay attention to the Cables connected, and install by hanging the Hook of the Display Stand Unit to the History Display Bottom Cover (Cover A), then affix all with 4 screws and 1 nut.

Fasteners		Qty	Appearance
Ab	TRUSS M4x8 BLK	4	
R	FLANGE NUT M4	1	

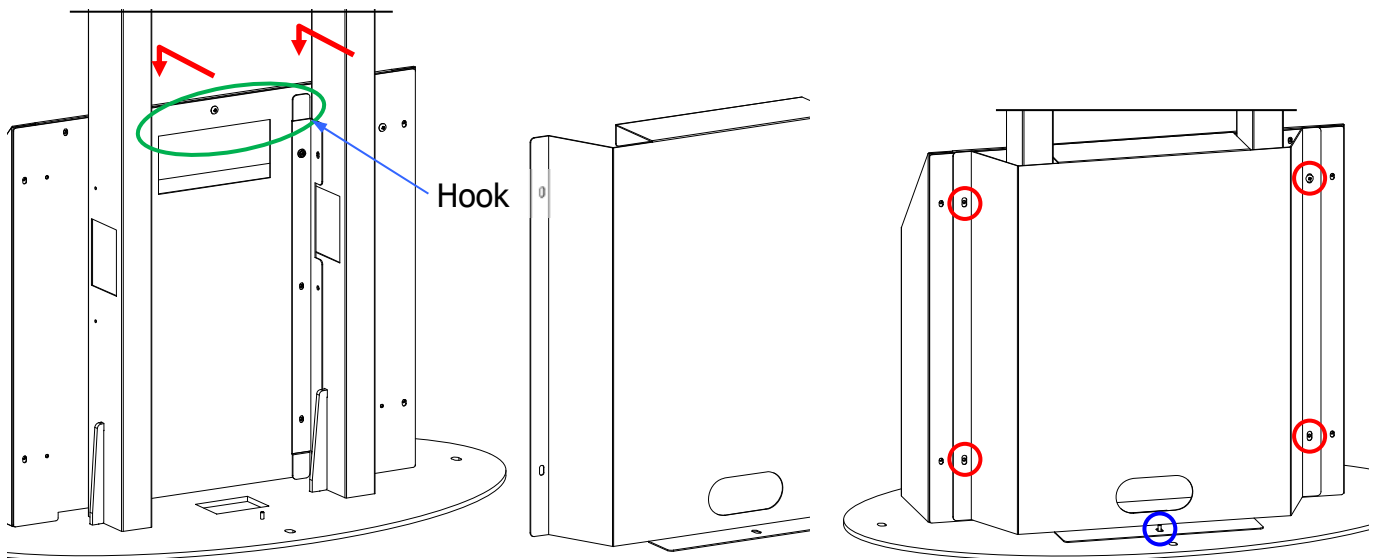

20. Locate the HDMI and H Connectors arranged on the Switch Box side of the Center Unit, and pull out the HDMI Connector through the hole at the bottom of the Center Unit.

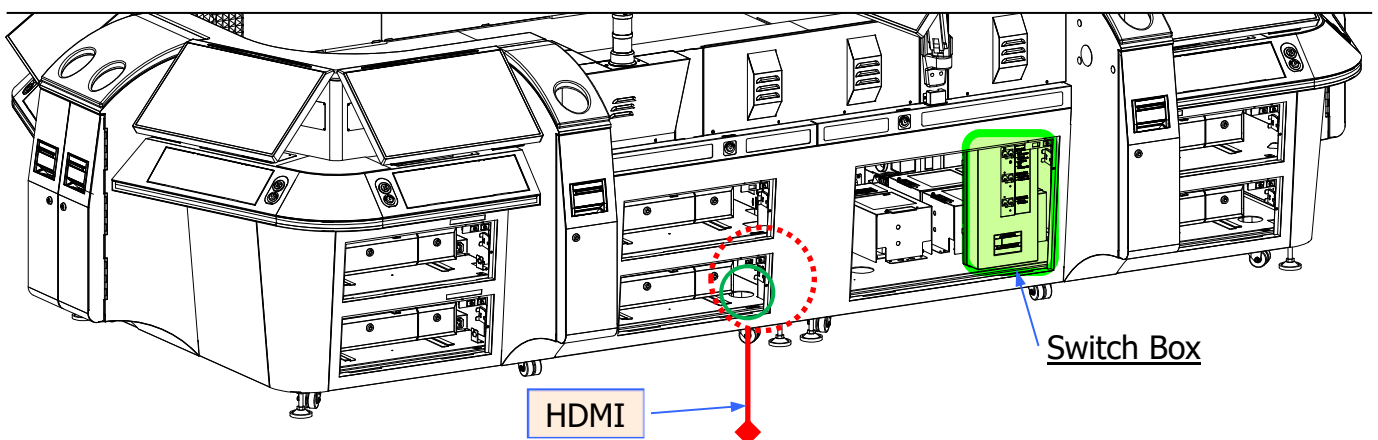

21. Connect the HDMI Connector from the Center Unit to the HDMI from the Display Stand Unit, then connect the AC Cable of the Display Stand Unit to the previously prepared power socket. Lead the remaining cable from the Display Stand Unit inside the Shelf through the hole at the bottom of the Center Unit, then connect the H Connector to the H Connector inside the Shelf, and the Earth Cable to the Earth Cable of the Main Controller Unit.

⚠ CAUTION!

The Power Switch of the Display Unit, is fixed on ON, so connecting the AC Cable of the Display Unit to an electrified Power Source will boot it ON. **(The Controller Unit does not boot up, so no images will be displayed on the Display Unit).** Do not electrify the Power Source.

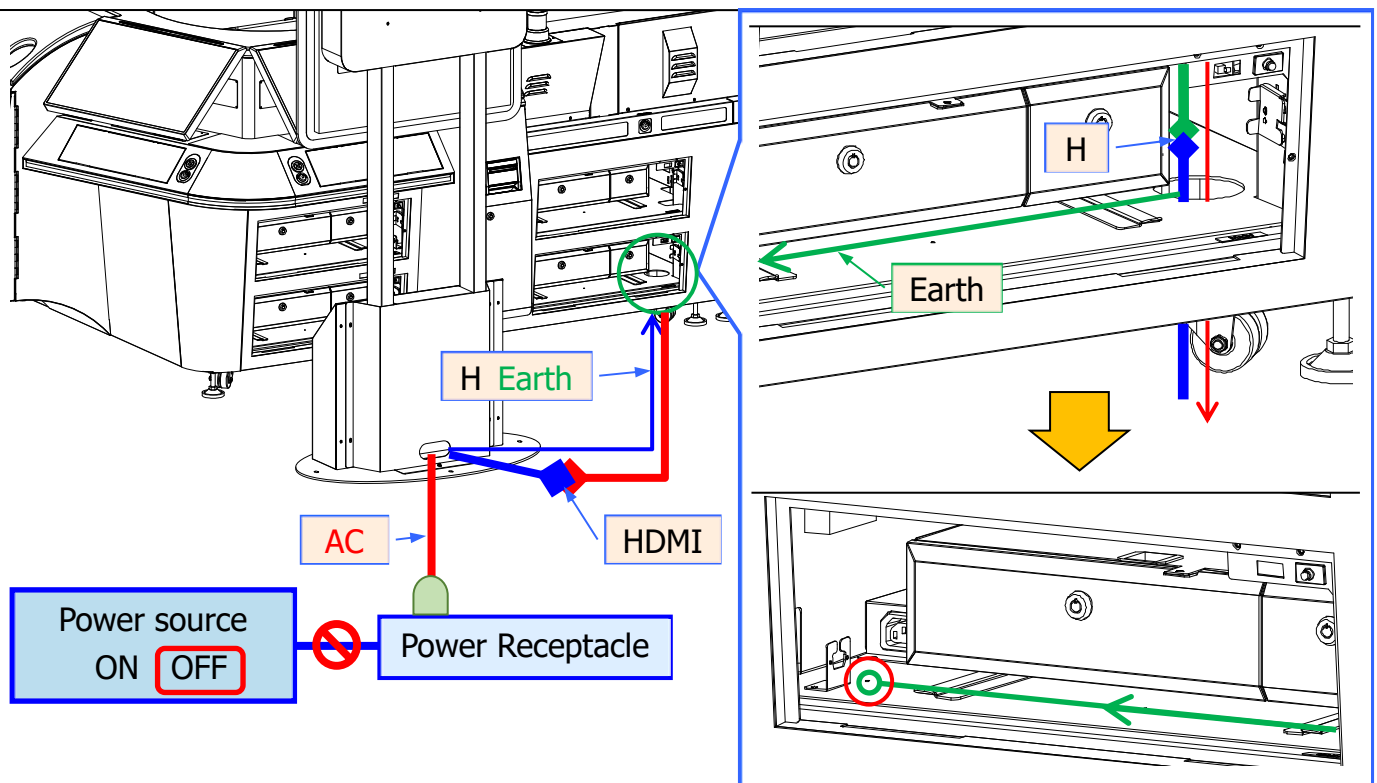
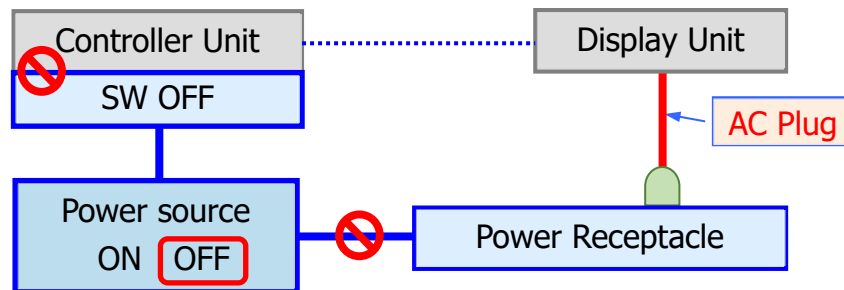

3. 2. 17: Installing the External monitors

NOTE: Option-4

In case it was chosen the Option to install External monitors, from this point refer to the procedures indicated as **Option-4**. If this Option was not chosen, continue from 3.2.18.

Option-4

NOTE:

- Please use external Monitors with no audio output. If an external Monitor with audio output is connected, there will be no more audio from the main machine of "ROLL TO WIN CRAPS".
- It is necessary to use a Monitor with ① **Input Port : DVI** for the **[Betting Status]** review. It is necessary to use a Monitor with ② **Input Port : DP or HDMI** for the streaming of the **[GAME Field and WALL Display]**. Please pay attention because the Input Port to use is limited by each video output type.

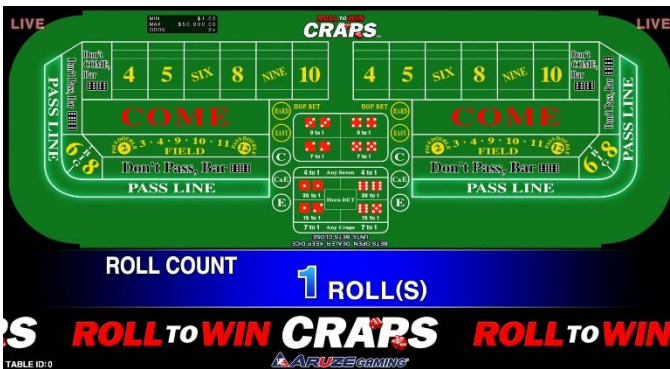

[GAME Field and WALL Display]

TABLE ID:0	08/03/2021 05:12										GAME:1	BET TIME	1/4
	Torainal 10	Torainal 9	Torainal 8	Torainal 7	Torainal 6	Torainal 5	Torainal 4	Torainal 3	Torainal 2	Torainal 1			
PASS LINE	\$0.00	\$0.00	\$0.00	\$0.00	\$0.00	\$0.00	\$0.00	\$0.00	\$0.00	\$0.00	\$0.00	\$0.00	
ODDS	\$0.00	\$0.00	\$0.00	\$0.00	\$0.00	\$0.00	\$0.00	\$0.00	\$0.00	\$0.00	\$0.00	\$0.00	
COME 4	\$0.00	\$0.00	\$0.00	\$0.00	\$0.00	\$0.00	\$0.00	\$0.00	\$0.00	\$0.00	\$0.00	\$0.00	
COME 5	\$0.00	\$0.00	\$0.00	\$0.00	\$0.00	\$0.00	\$0.00	\$0.00	\$0.00	\$0.00	\$0.00	\$0.00	
COME 6	\$0.00	\$0.00	\$0.00	\$0.00	\$0.00	\$0.00	\$0.00	\$0.00	\$0.00	\$0.00	\$0.00	\$0.00	
COME 8	\$0.00	\$0.00	\$0.00	\$0.00	\$0.00	\$0.00	\$0.00	\$0.00	\$0.00	\$0.00	\$0.00	\$0.00	
COME 9	\$0.00	\$0.00	\$0.00	\$0.00	\$0.00	\$0.00	\$0.00	\$0.00	\$0.00	\$0.00	\$0.00	\$0.00	
COME 10	\$0.00	\$0.00	\$0.00	\$0.00	\$0.00	\$0.00	\$0.00	\$0.00	\$0.00	\$0.00	\$0.00	\$0.00	
COME ODDS 2	\$0.00	\$0.00	\$0.00	\$0.00	\$0.00	\$0.00	\$0.00	\$0.00	\$0.00	\$0.00	\$0.00	\$0.00	
COME ODDS 3	\$0.00	\$0.00	\$0.00	\$0.00	\$0.00	\$0.00	\$0.00	\$0.00	\$0.00	\$0.00	\$0.00	\$0.00	
COME ODDS 4	\$0.00	\$0.00	\$0.00	\$0.00	\$0.00	\$0.00	\$0.00	\$0.00	\$0.00	\$0.00	\$0.00	\$0.00	
COME ODDS 5	\$0.00	\$0.00	\$0.00	\$0.00	\$0.00	\$0.00	\$0.00	\$0.00	\$0.00	\$0.00	\$0.00	\$0.00	
COME ODDS 6	\$0.00	\$0.00	\$0.00	\$0.00	\$0.00	\$0.00	\$0.00	\$0.00	\$0.00	\$0.00	\$0.00	\$0.00	
COME ODDS 8	\$0.00	\$0.00	\$0.00	\$0.00	\$0.00	\$0.00	\$0.00	\$0.00	\$0.00	\$0.00	\$0.00	\$0.00	
COME ODDS 9	\$0.00	\$0.00	\$0.00	\$0.00	\$0.00	\$0.00	\$0.00	\$0.00	\$0.00	\$0.00	\$0.00	\$0.00	
COME ODDS 10	\$0.00	\$0.00	\$0.00	\$0.00	\$0.00	\$0.00	\$0.00	\$0.00	\$0.00	\$0.00	\$0.00	\$0.00	
PLACE 4	\$0.00	\$0.00	\$0.00	\$0.00	\$0.00	\$0.00	\$0.00	\$0.00	\$0.00	\$0.00	\$0.00	\$0.00	
PLACE 5	\$0.00	\$0.00	\$0.00	\$0.00	\$0.00	\$0.00	\$0.00	\$0.00	\$0.00	\$0.00	\$0.00	\$0.00	
PLACE 6	\$0.00	\$0.00	\$0.00	\$0.00	\$0.00	\$0.00	\$0.00	\$0.00	\$0.00	\$0.00	\$0.00	\$0.00	
PLACE 8	\$0.00	\$0.00	\$0.00	\$0.00	\$0.00	\$0.00	\$0.00	\$0.00	\$0.00	\$0.00	\$0.00	\$0.00	
PLACE 9	\$0.00	\$0.00	\$0.00	\$0.00	\$0.00	\$0.00	\$0.00	\$0.00	\$0.00	\$0.00	\$0.00	\$0.00	
PLACE 10	\$0.00	\$0.00	\$0.00	\$0.00	\$0.00	\$0.00	\$0.00	\$0.00	\$0.00	\$0.00	\$0.00	\$0.00	
BUY 4	\$0.00	\$0.00	\$0.00	\$0.00	\$0.00	\$0.00	\$0.00	\$0.00	\$0.00	\$0.00	\$0.00	\$0.00	
BUY 5	\$0.00	\$0.00	\$0.00	\$0.00	\$0.00	\$0.00	\$0.00	\$0.00	\$0.00	\$0.00	\$0.00	\$0.00	
BUY 6	\$0.00	\$0.00	\$0.00	\$0.00	\$0.00	\$0.00	\$0.00	\$0.00	\$0.00	\$0.00	\$0.00	\$0.00	

[Betting status]

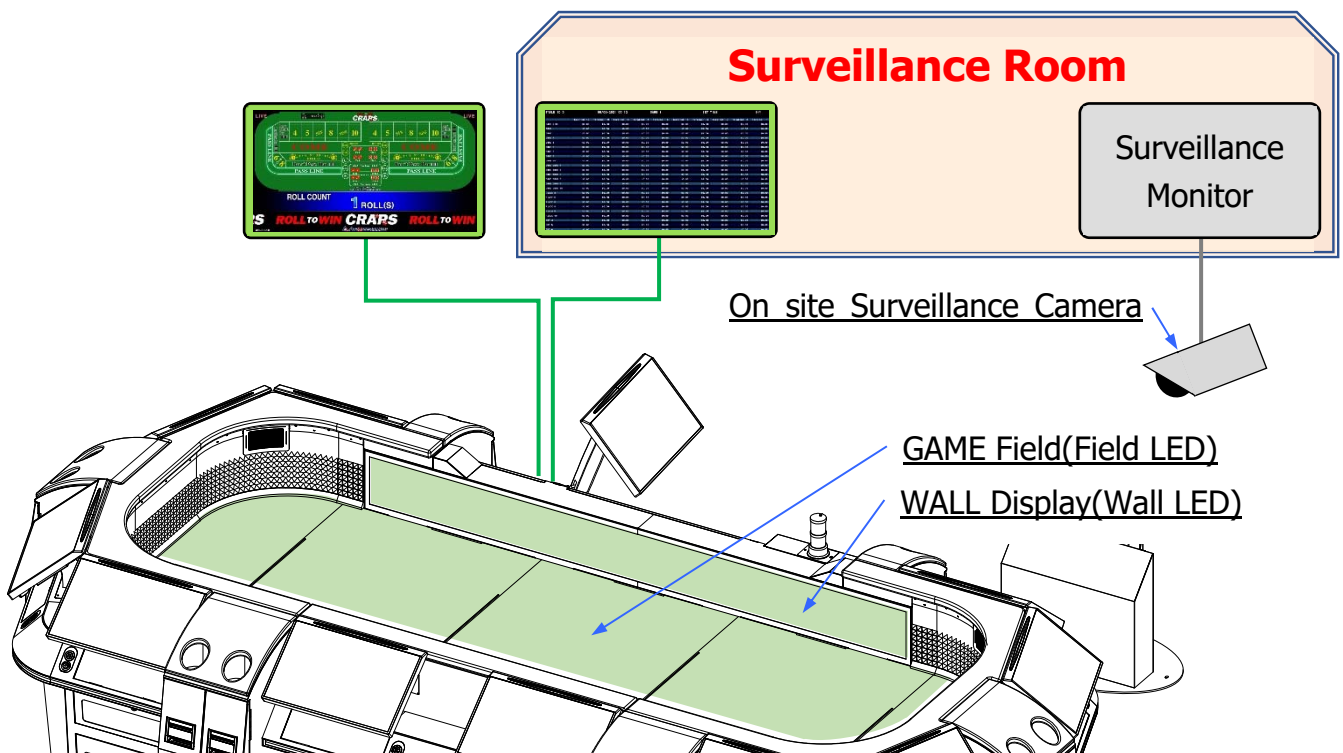

3. 2. 17. 1: [Betting status] for Surveillance Monitor

1. Unlock and open the Main Door Lock of **the Signage Controller Unit**.

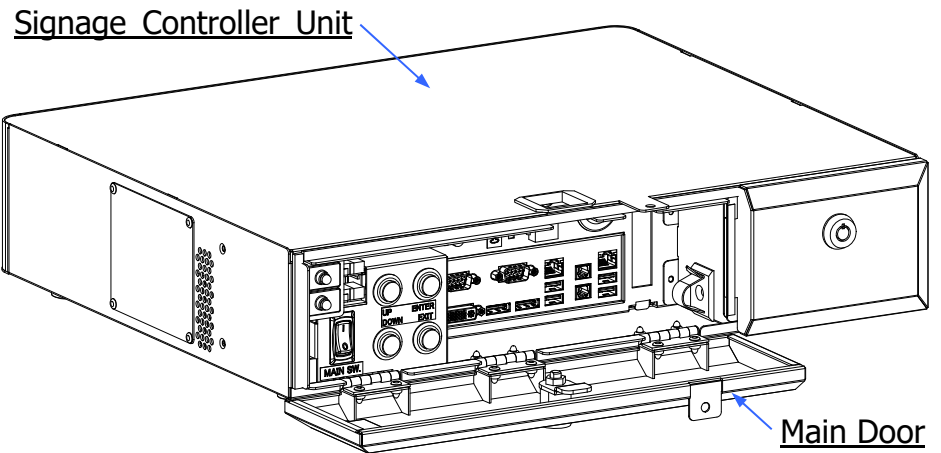
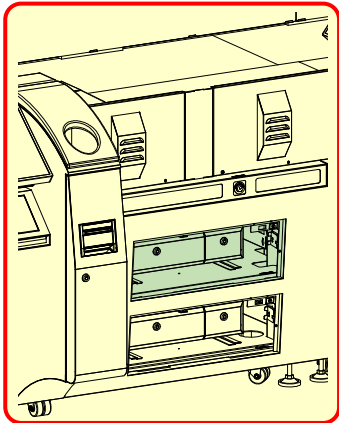

2. Prepare the following Parts.

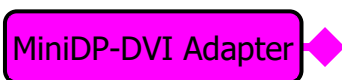
Parts Name	Qty	Appearance
External Monitor for [Betting status] Use an external Monitor with DVI Input port and <u>no audio output</u> .	1	Input Port  DVI
MiniDP-DVI_ACTIVE KS30015-00E Item code : 6P1046100 for [Betting status]	1	
DVI Cable for [Betting status] Choose the cable length according to the installation environment.	1	

3. Refer to the illustration below to connect the MiniDp Connector of the MiniDP-DVI Adapter to the MDP2 Port of the Signage Controller Unit, and the DVI Cable for external monitor use to the MiniDP-DVI Adapter. (Pay attention to not to use the wrong port).

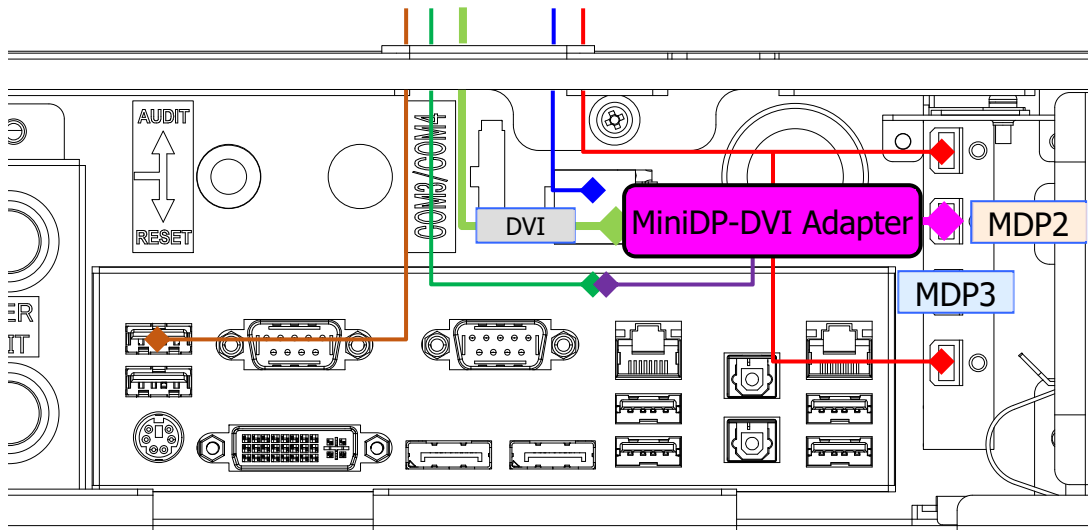

4. Pull the opposite side of the Cable through the hole at the bottom of the Center Unit and connect it to the external Monitor with no audio output.

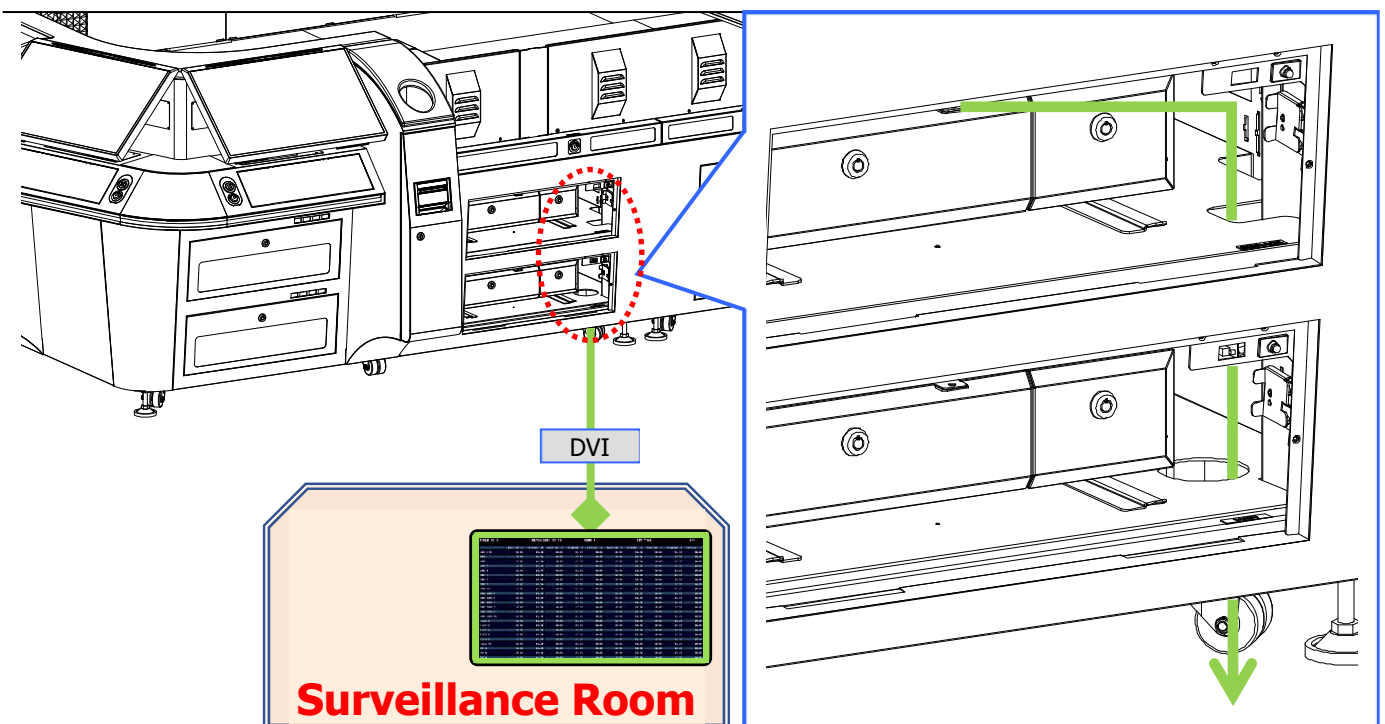

3. 2. 17. 2: [GAME Field and WALL Display] for Audience Live viewing Monitor

1. Unlock and open the Main Door Lock of **the Signage Controller Unit**.

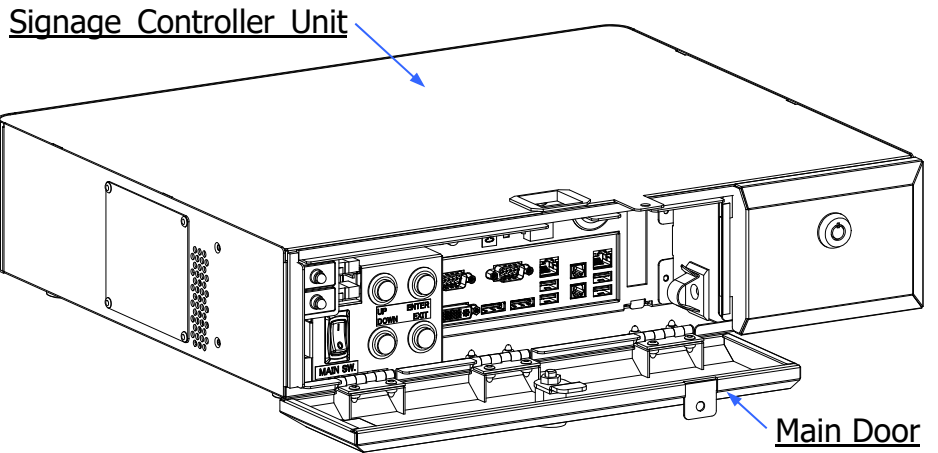
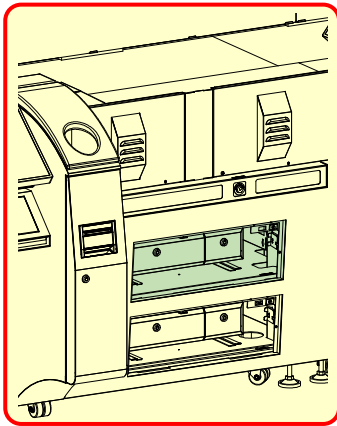

2. Prepare the following Parts.

Parts Name	Qty	Appearance
External Monitor for [GAME Field and WALL Display] Use an external Monitor with DP or HDMI Input port and <u>no audio output.</u>	1	Input Port  DP or HDMI
MiniDP-DP(or MiniDP-HDMI) Cable for [GAME Field and WALL Display] Choose the cable length according to the Input Port of the Monitor and the installation environment.	1	

- Refer to the illustration below to connect the Mini DP Connector of the MiniDP-DP (or MiniDP-HDMI) Cable to the MDP3 Port of the Signage Controller Unit. **(Pay attention to not to use the wrong port).**

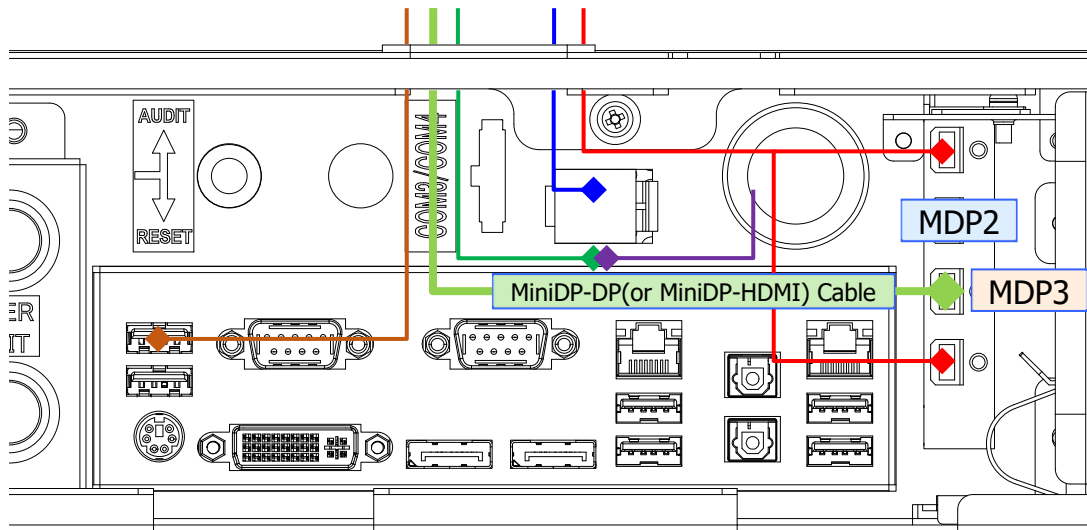

- Pull the opposite side of the Cable through the hole at the bottom of the Center Unit and connect it to the external Monitor with no audio output.

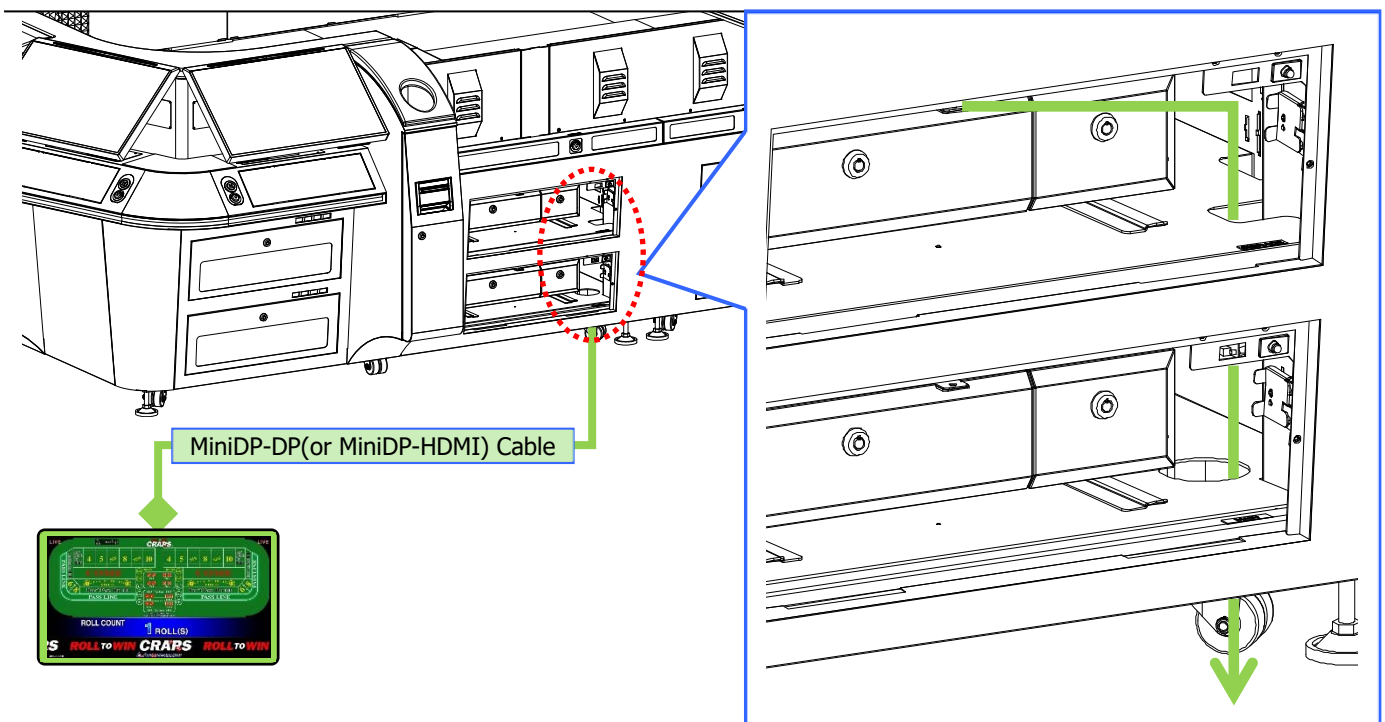

3. 2. 18: Installing the Doors onto the Center Unit

1. Prepare the following Parts.

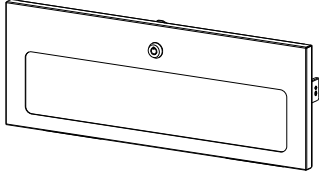
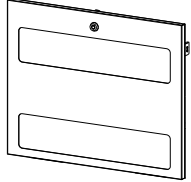
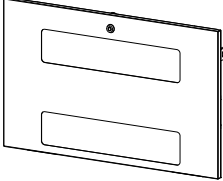
Parts Name	Qty	Appearance
Front Door(for Signage, Main, Station)	12	
Controller Door(Main DR A)	1	
Power Door(Main DR B)	1	

i NOTE:

If the locks are changed for increased security, please refer to **"Key Locks"** on Chapter 3 of the SERVICE MANUAL to perform the work.

2. Install all the Doors on the Center Unit.

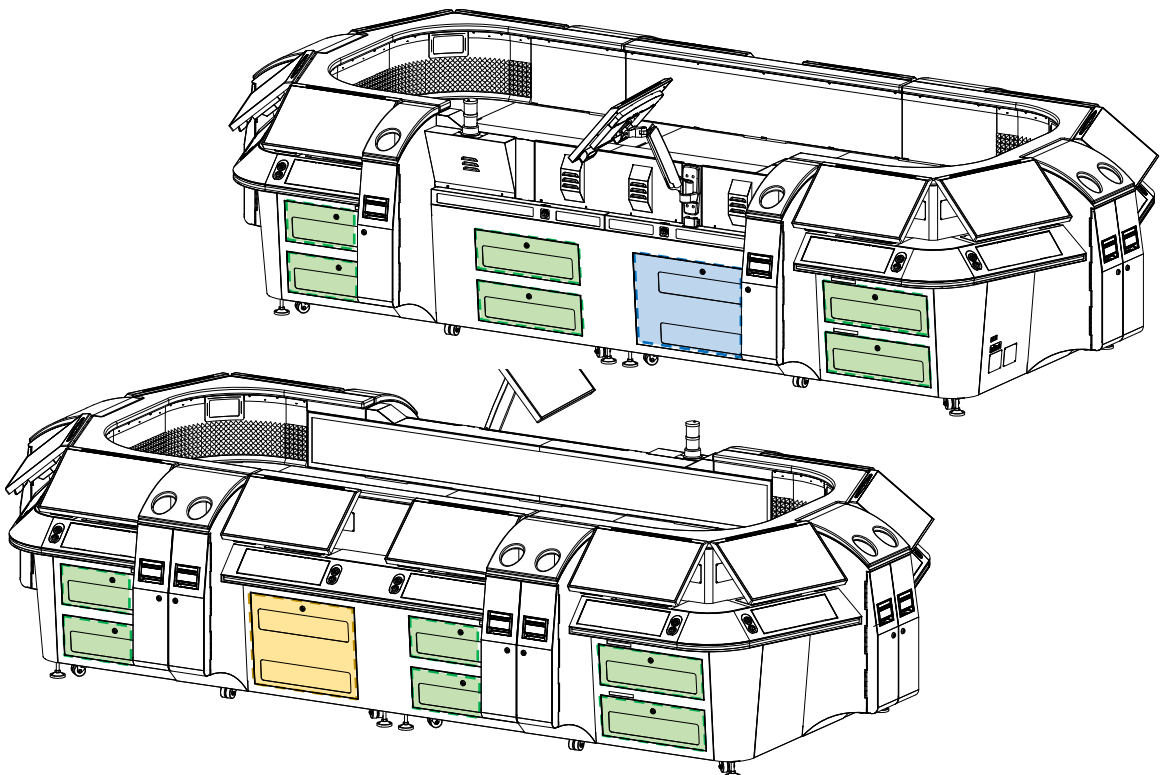

3. 2. 19: Checking and Setting

Before turning ON the Center Unit, check the following;

- All the cable connectors are securely seated.
- The machine is properly earthed.



CAUTION!

- Make sure that the Switches of all the Controller Units are switched to ON.
- Please leave these switches on ON and do not change their status.

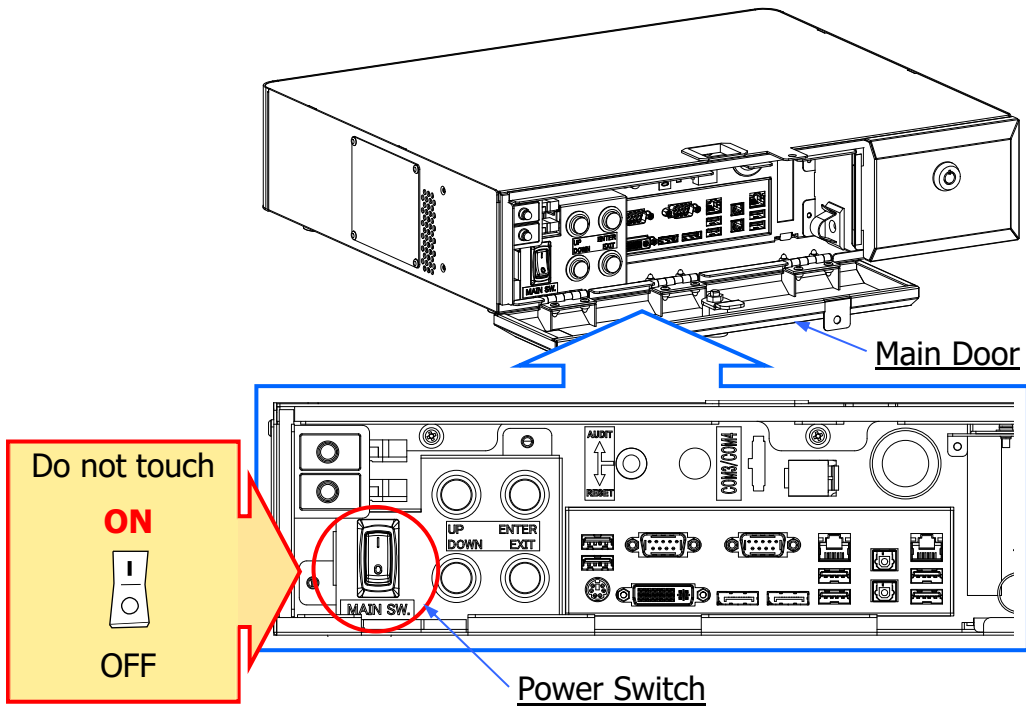

3. 2. 19. 1: Checking Operation of Center Unit

CAUTION!

At this point, turn ON only the switches of the Main Controller Units and of the Signage Controller Unit.

1. First turn ON the power source. The machines directly connected to the power source will boot up. (The Controller Unit does not boot up, so no images will be displayed on the Field LED Unit and the Wall LED Unit)

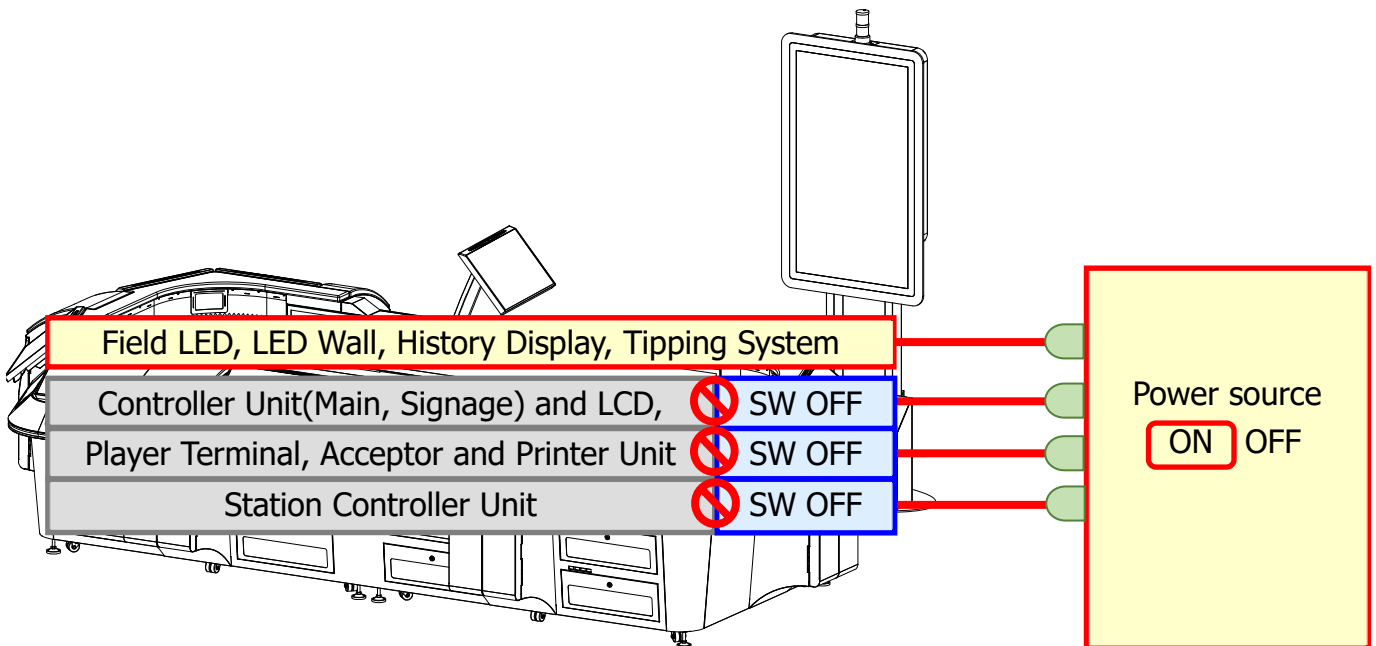

- Open the Power Door (Main DR B) of the Center Unit, turn to ON the Power Switch "MAIN SW 1", and then close the Power Door (Main DR B). The Main Controller Unit and the Signage Controller Unit will boot up, and the images will be displayed on the Field LED Unit, the Wall LED Unit, the Dealer Terminal and the History Display Unit (Option). During the start-up self test, on the monitor is displayed "**NOW CHECKING**" for the item "**Program test**". The display turns to "**OK**" when the check is successfully complete.

⚠ CAUTION!

- When doing "Power OFF-ON" wait at least 15 seconds before power On.
- Do not touch the Touch Screen when "**NOW CHECKING**" is displayed. This may lead to Touch Screen malfunction.

i NOTE:

- If an error appears, refer to Operation Manual Chapter 8 "**Error Messages**" to clear it.
- If it is necessary to perform the RAM Clear (Memory Clear), refer to Chapter 6 of the Service Manual, "**Memory Clear Procedure**".
- When the machine was shipped, the touch Screens were calibrated. However, if needed, calibrate the touch Screens referring to Chapter 4 of the Service Manual, "**Touch Screen Settings**".

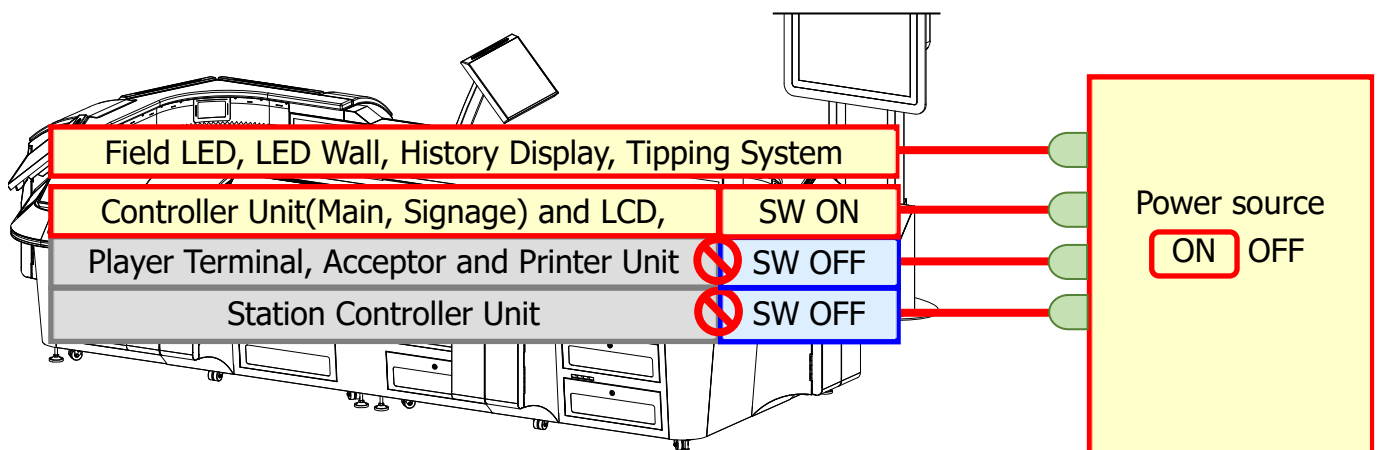
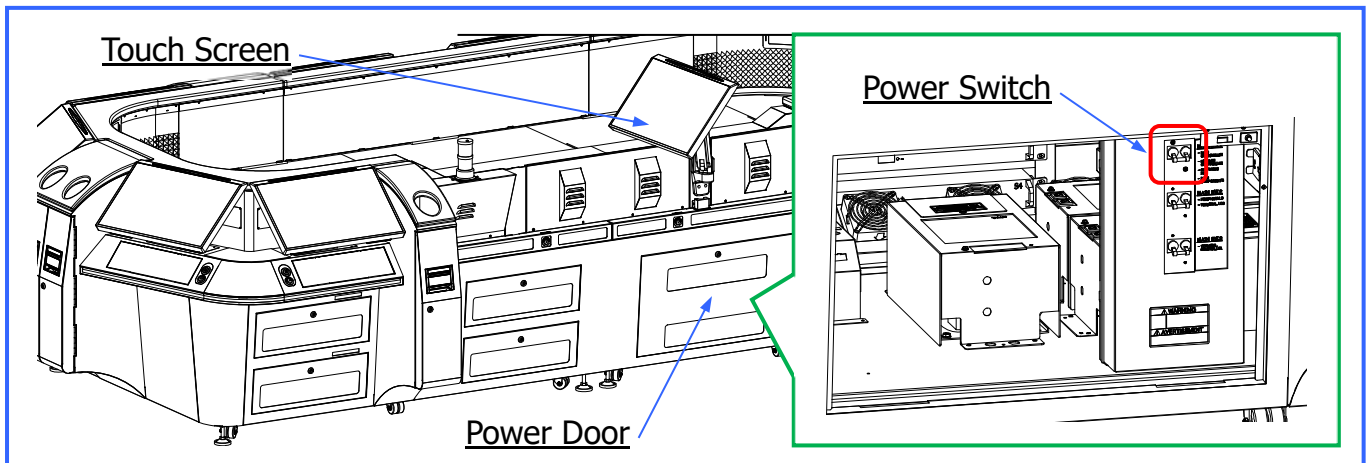

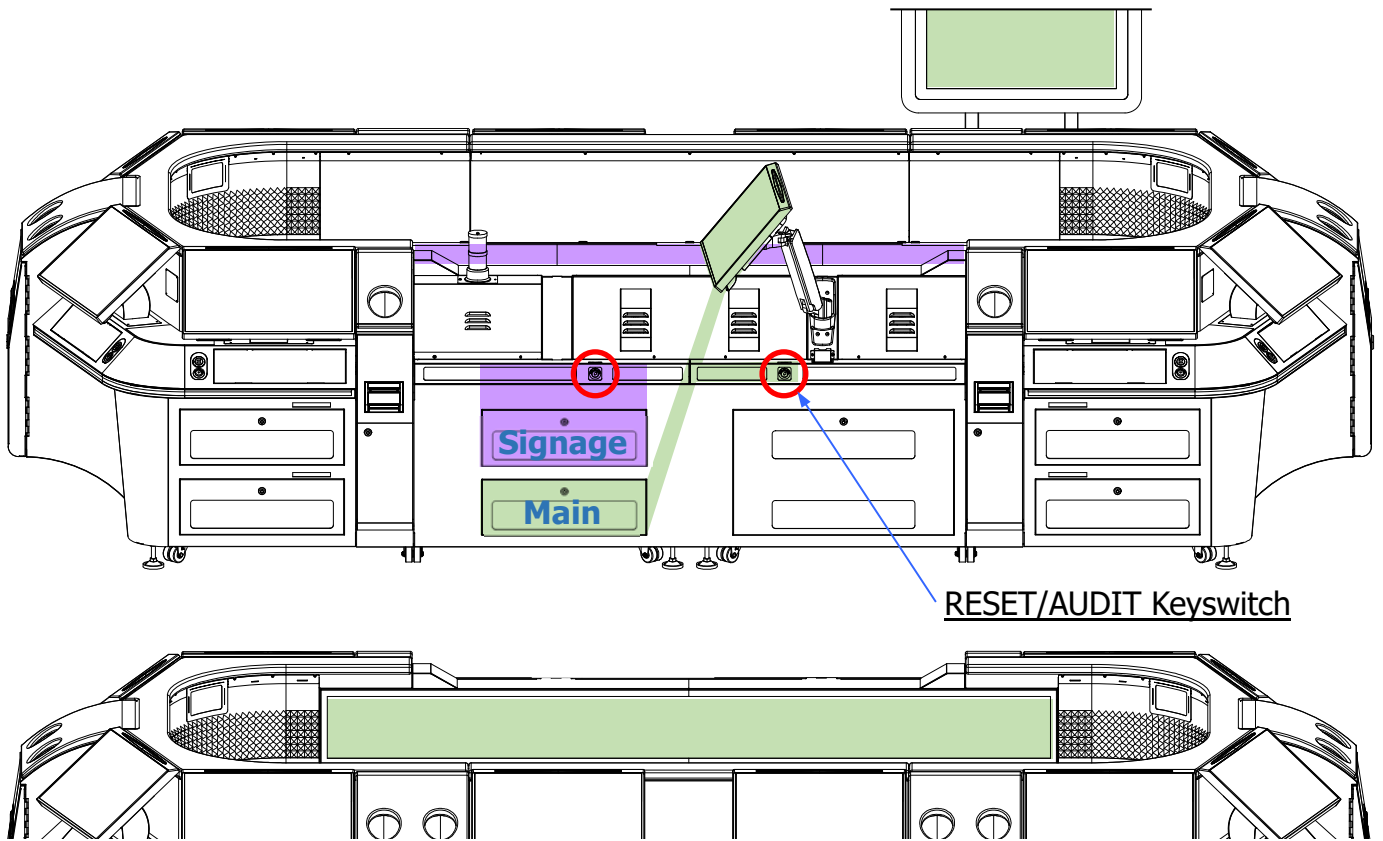

3. Open the Front Main Door of the Center Unit.

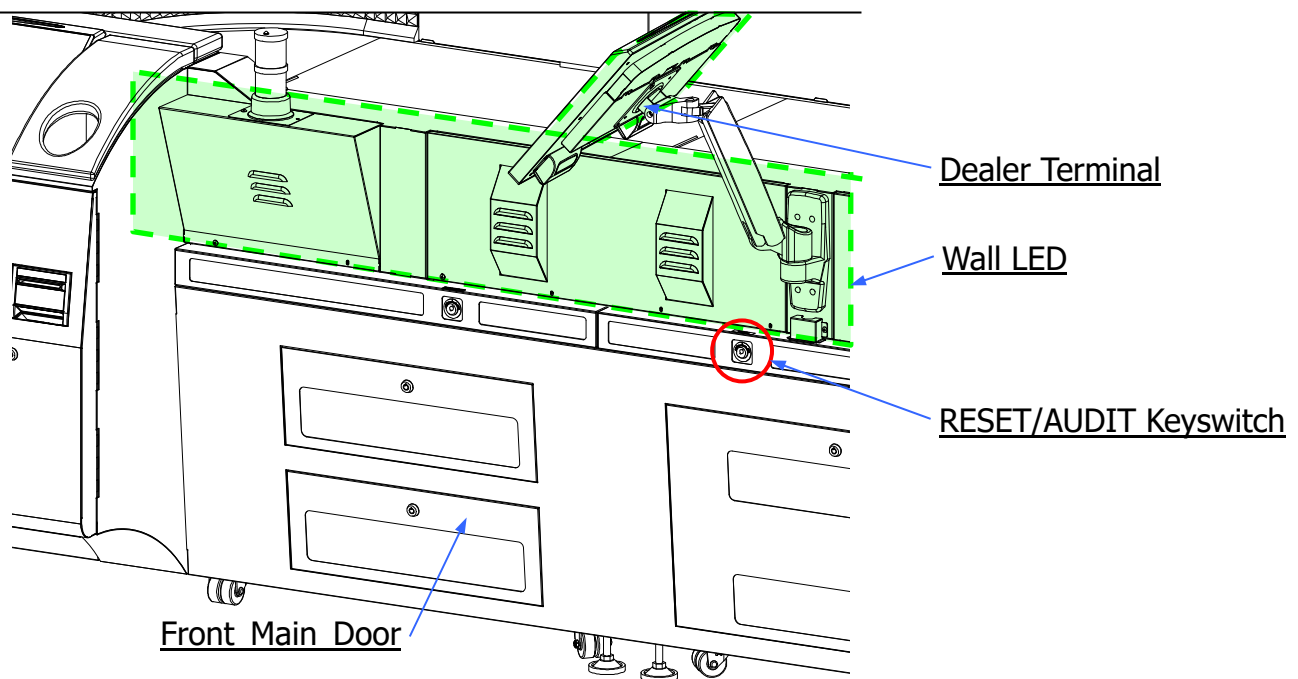



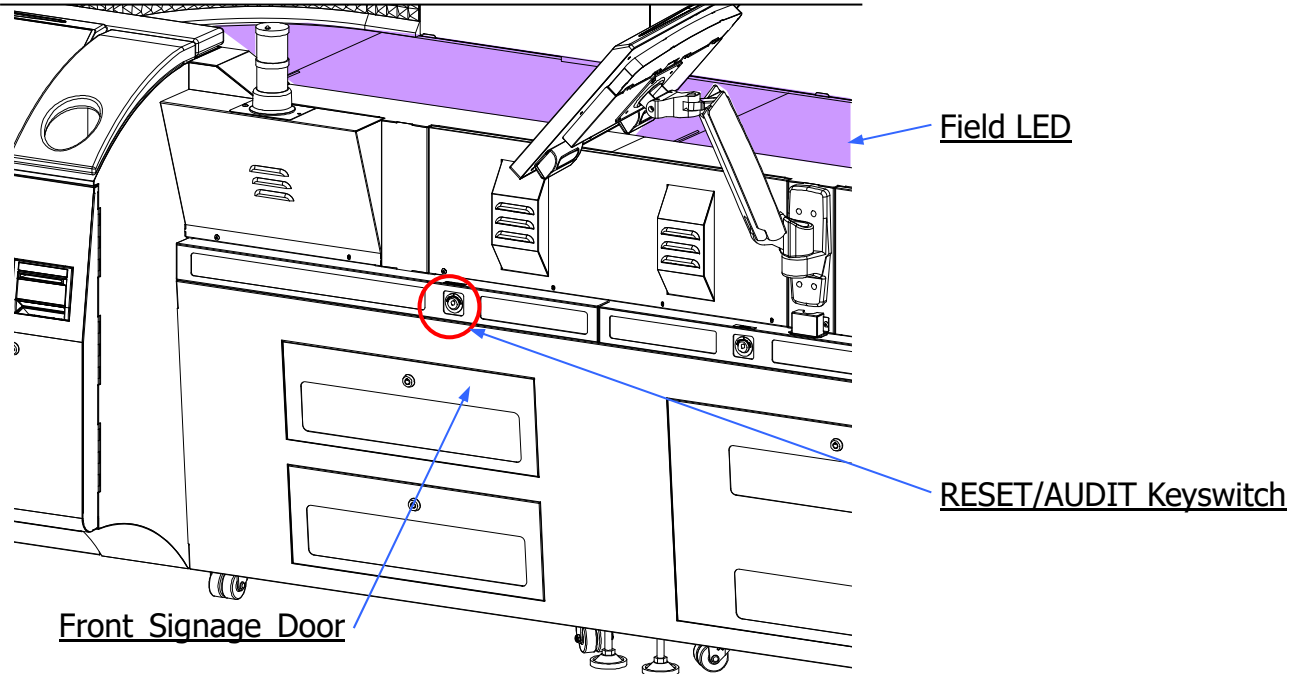

4. It is possible to navigate the AUDIT by using the Touch Panel of the Dealer Terminal.
5. Do not close the door, and select on the AUDIT TOP MENU>TEST>OUTPUT TEST. Check if all the illuminations are properly working, including the History Display Unit (Option).

6. Select on the AUDIT TOP MENU>TEST>SOUND TEST to check if the speakers of the Dealer Terminal Unit are properly playing sounds.
7. Exit the AUDIT and close the Front Main Door of the Center Unit.
8. Continue the procedure by opening the Front Signage Door of the Center Unit.



9. The image of the AUDIT will be displayed on the Wall LED. Navigate it by using the Keyboard connected to the Signage Controller Unit.

#	Item Name	Functionality
1		Used to move up the cursor.
2		Used to move down the cursor.
3		Used to enter your selection.
4		Used to cancel your selection.

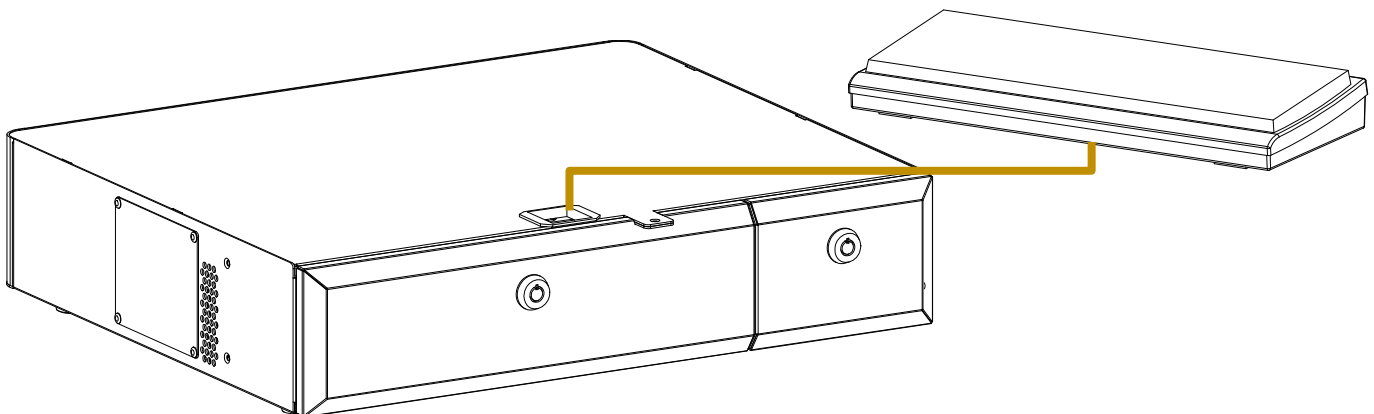

10. Do not close the door, and select on the AUDIT TOP MENU>TEST>SOUND TEST to check if the speakers of the Side Wall Unit are properly playing sounds.
11. Exit the AUDIT and close the Front Signage Door of the Center Unit.
12. Check that the "Place your bet!" call and the background music are played.

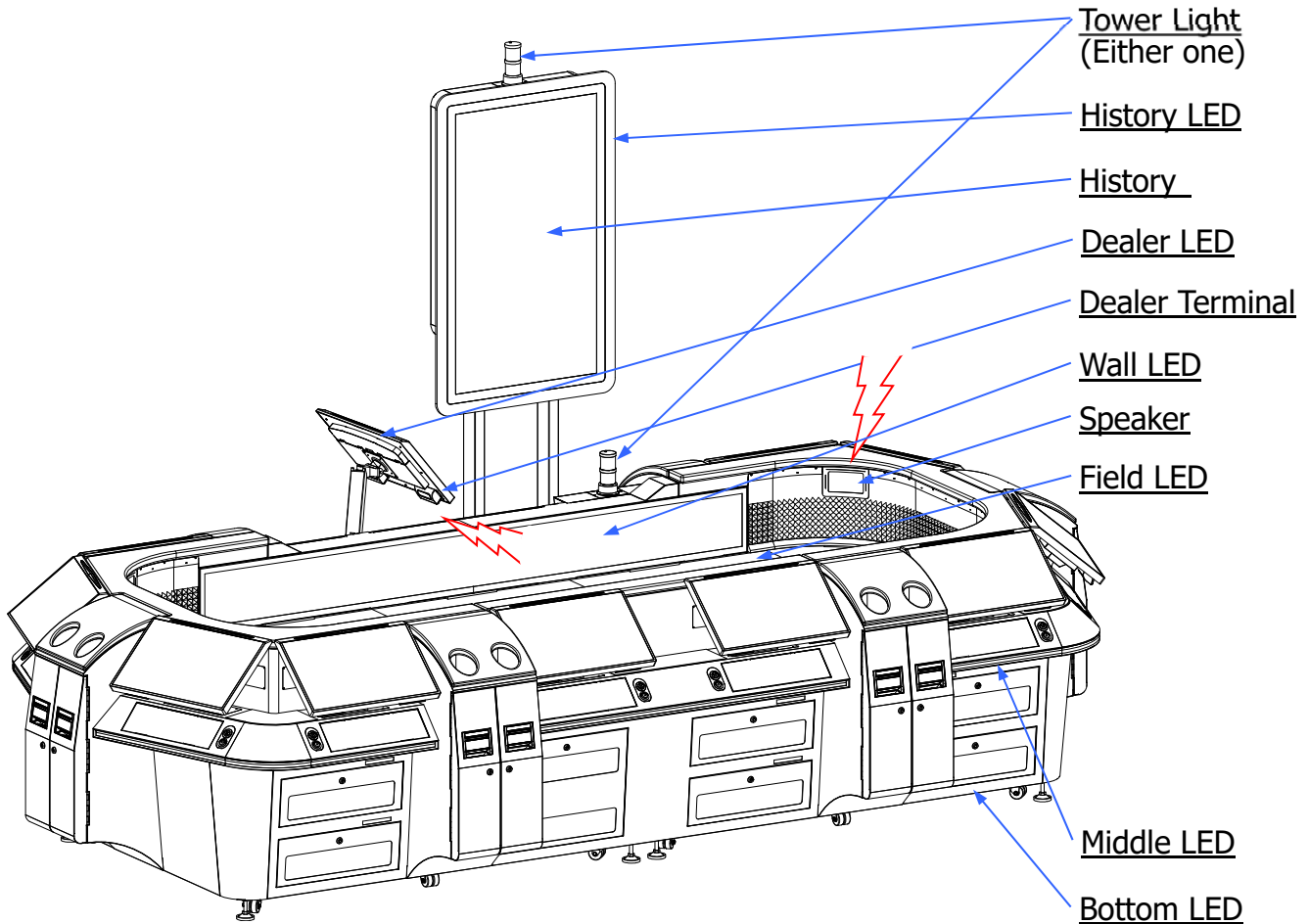

3. 2. 19. 2: Checking Operation of Player Terminal

1. Refer to 3.2.18.1 and boot on the Main Controller Unit and the Signage Controller Unit.

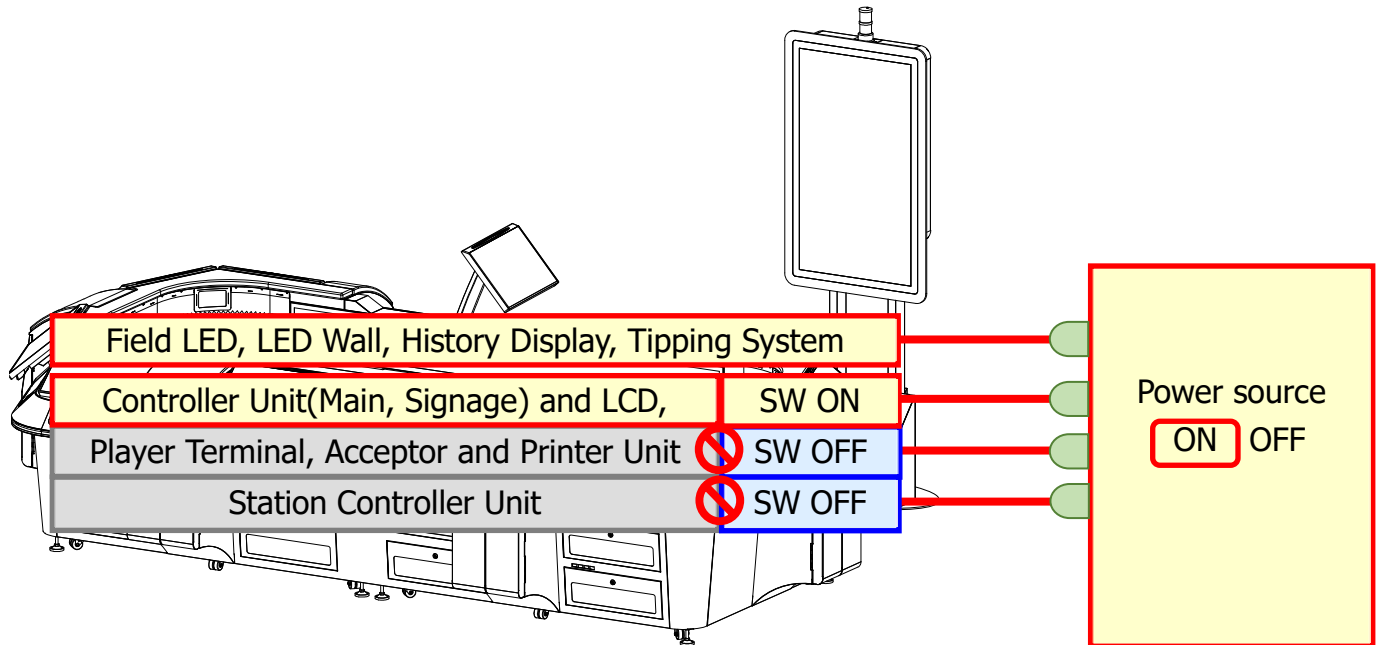

- Open the Power Door (Main DR B) of the Center Unit, turn to ON the Power Switches "MAIN SW 2" and "MAIN SW 3", and then close the Power Door (Main DR B). The Station Controller Unit will boot up, and the images will be displayed on each Player Terminal. During the start-up self test, on the monitor is displayed "**NOW CHECKING**" for the item "**Program test**". The display turns to "**OK**" when the check is successfully complete.

⚠ CAUTION!

- Do not turn ON the Power switches at the same time. Doing so can result in a start-up error of the machine.
- When doing "Power OFF-ON" wait at least 15 seconds before power On.
- Do not touch the Touch Screen when "**NOW CHECKING**" is displayed. This may lead to Touch Screen malfunction.

i NOTE:

- If an error appears, refer to Operation Manual Chapter 8 "**Error Messages**" to clear it.
- If it is necessary to perform the RAM Clear (Memory Clear), refer to Chapter 7 of the Service Manual, "**Memory Clear Procedure**".
- When the machine was shipped, the touch Screens were calibrated. However, if needed, calibrate the touch Screens referring to Chapter 5 of the Service Manual, "**Touch Screen Settings**".

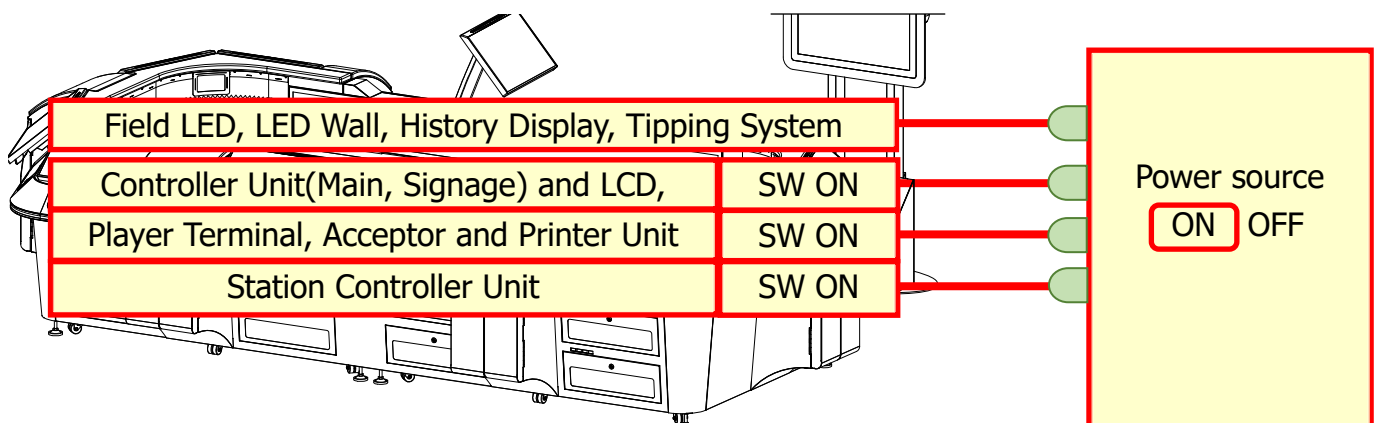
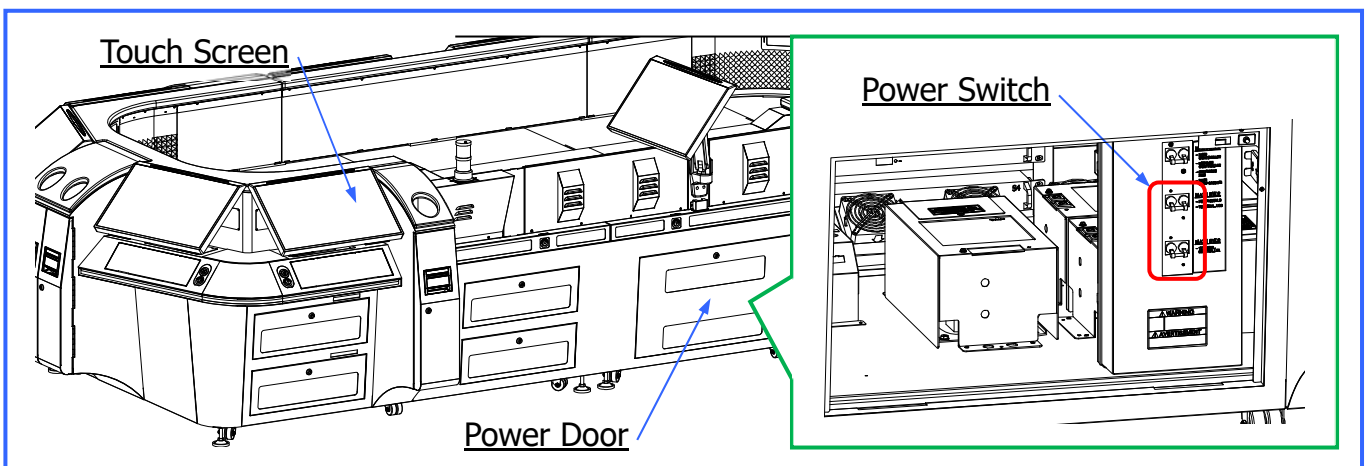

3. Refer to the illustration below to set the ID No. of the Station Controller Units.

i NOTE:

At first it is needed to set the "Station ID Number" of the Station Controller Unit.

A: Open the Main Door and the Security Door of the Station Controller Unit.



B: Do not close the door, and select on the AUDIT TOP MENU>SETTINGS>IMPORTANT SETTINGS>STATION ID NUMBER. Refer to the illustration below to set the ID No. 1-10 to the Station Controller Units, and then exit the AUDIT. All the Player Terminals will display a **"Turn OFF and ON the Machine to make the Update effective."** message. ✖The ID Number can be checked on the ID Sticker visible on the front right when opening the Front Door.

C: Open the Power Door(Main DR B) and turn OFF the Power Switches "MAIN SW2" and "MAIN SW 3". Wait at least 15 seconds and then turn the switches ON, one by one. Finally close the Power Door (Main DR B).

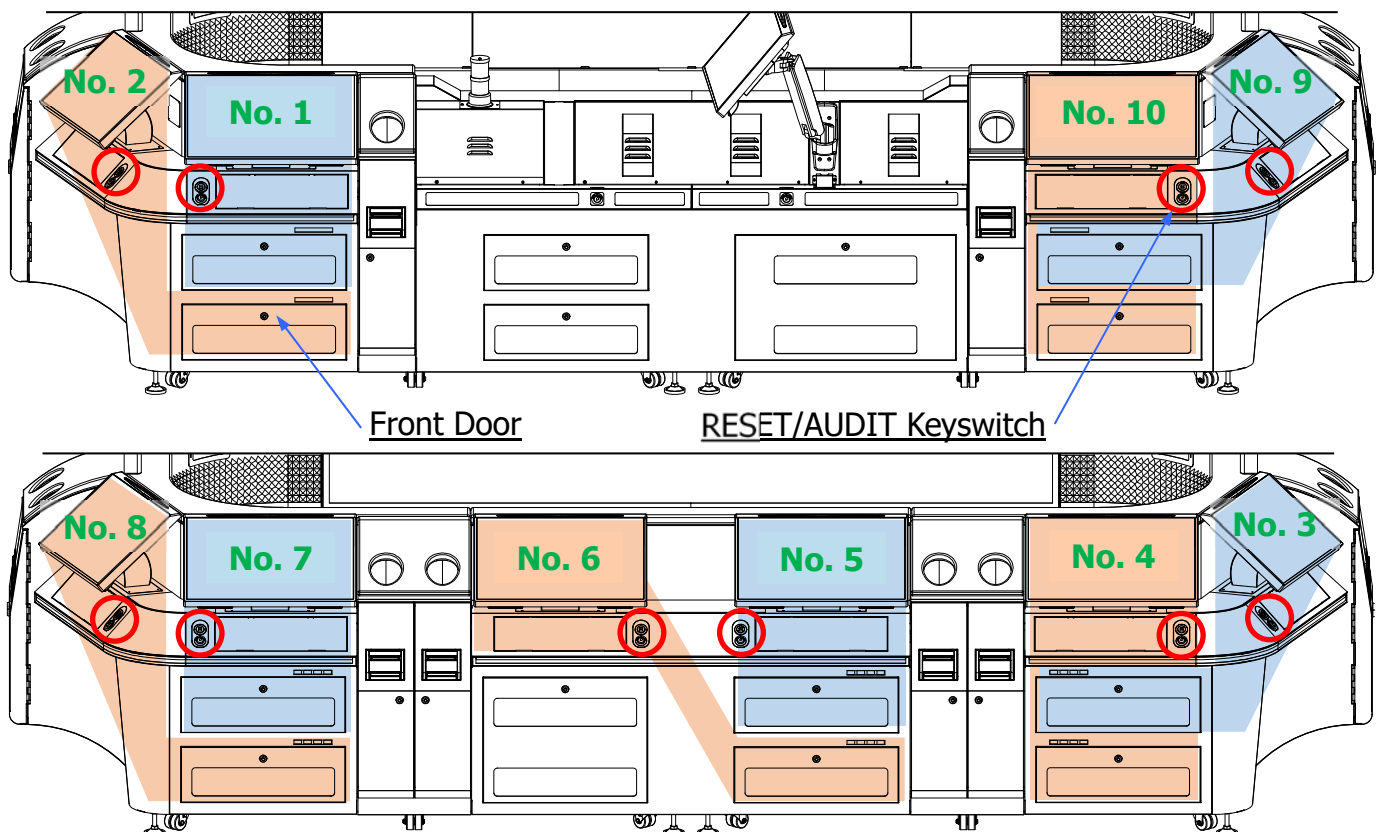
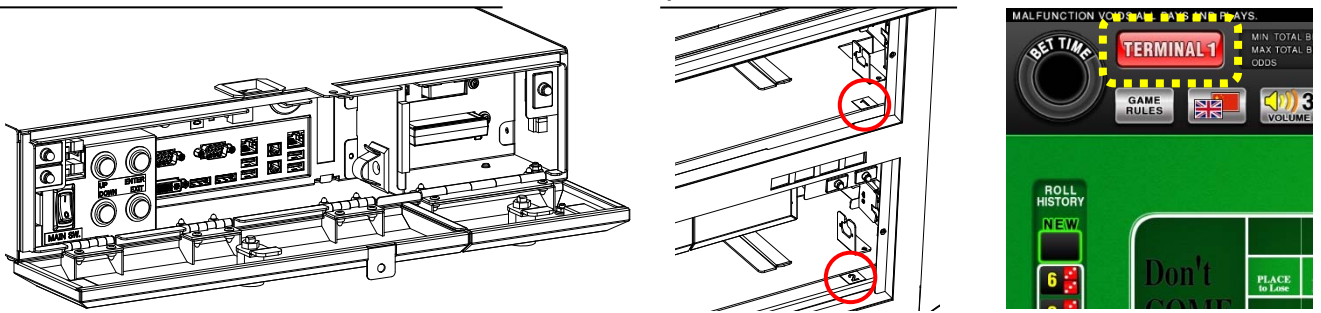
D: After the Station Controller Unit is booted up, check the ID No. on the Game Screen.



- The status of each Player Terminal is displayed by the color of the Player Terminal icon on the Dealer Terminal. It is also shown by the LED on the upper frame of the Dealer Terminal and the Player Terminals, as explained below.

Status	Player Terminal icon color of Dealer Terminal	Dealer Terminal LED	Player Terminal LED
Trouble. Error on the Dealer Terminal.	ERROR	Flash in red and blue	Flash in red and blue
Trouble. The Player Terminal is disconnected or there is an error on the Player Terminal.		White light	Flash in red and blue
Normal. 0 credit charged.		White light	Light OFF

- Open the Front Door of the Center Unit.
- Do not close the door, and select on the AUDIT TOP MENU>TEST>OUTPUT TEST. Check if all the illuminations are properly working, including the Ticket Entry & Chute.
- Select on the AUDIT TOP MENU>TEST>SOUND TEST to check if the speakers of the Player Terminal Units are properly playing sounds.
- Exit the AUDIT and close the Front Door of the Center Unit. Press repeatedly the GAME RULES button to check if the sound is played.

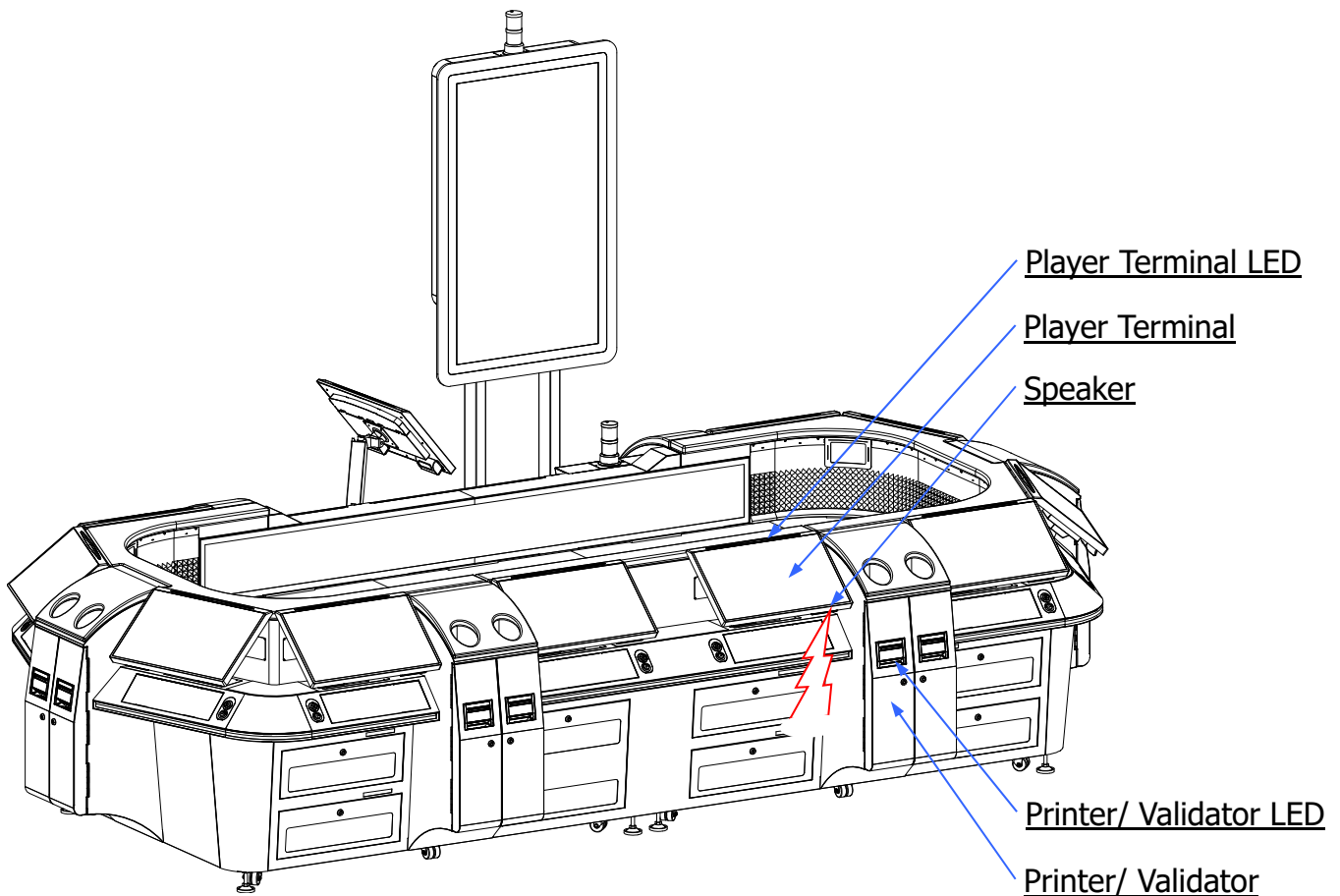

3. 2. 19. 3: Verifying Operation of Whole Machine

1. Verify the software setting of the Main Controller Unit, Signage Controller Unit and Station Controller Unit by referring to "**SETTING**" on Service Manual Chapter 4 and Chapter 5.
2. Verify that BILLS/Tickets are correctly counted by inserting bills/tickets.
3. Play 10 games on the Player Terminals to check if the game normally proceeds.

3. 2. 20: Installing the Field Bumps or the Field Fabric

i NOTE: Option-5

As Field Options, it is possible to choose either Field Bumps or Field Fabric.

3. 2. 20. 1: Field Bumps Specification

1. Prepare the following Parts.

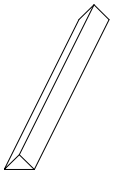
Parts Name	Qty	Appearance
Field Bump	4	

2. Refer to the illustration below and, keeping a distance of 3-5mm, align the 4 Field Bumps to the seams between the Urethan Sheets, then affix the Field Bumps.

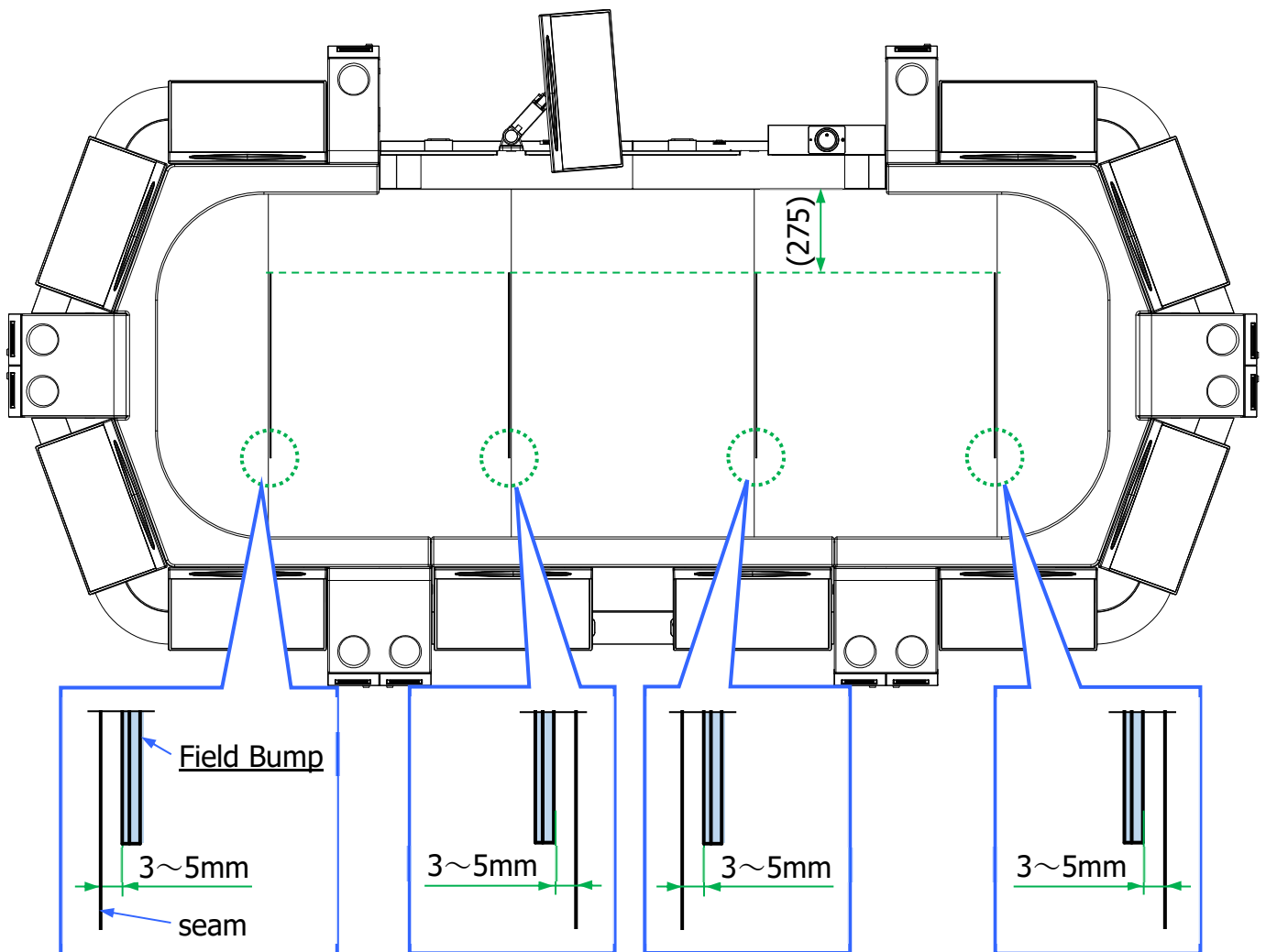

3. 2. 20. 2: Field Fabric Specification

1. Prepare the following Parts.

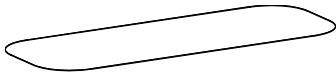
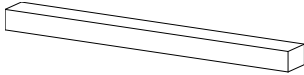
Parts Name	Qty	Appearance
Field Fabric	1	
Fabric Stopper	12	

2. Spread the Field Fabric over the Field, then stuck the hem of the Field Fabric inside the gap between the Wall and the Field.

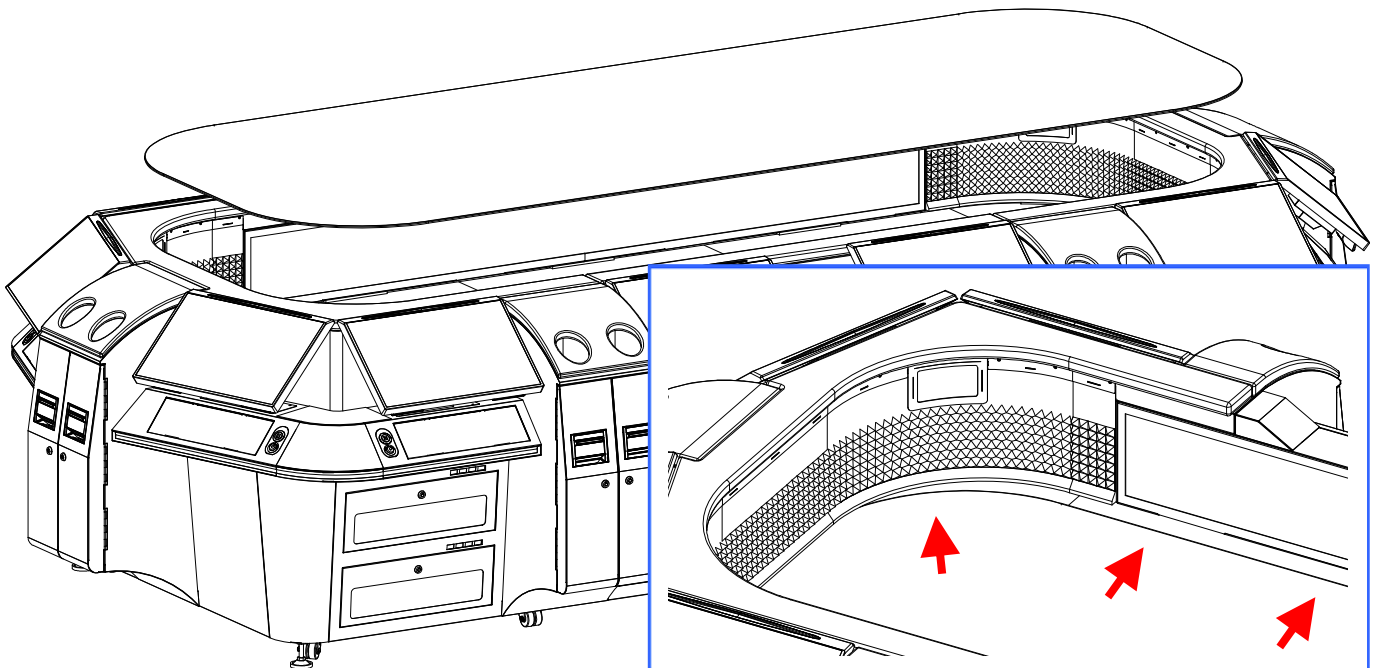

3. Insert the Fabric Stoppers inside the gap between the Wall and the Field in the 12 places indicated by the illustration below, and affix the Field Fabric so that it does not get loose.

i NOTE:

It is easier to avoid wrinkles if the Stoppers are inserted in order starting from the center.

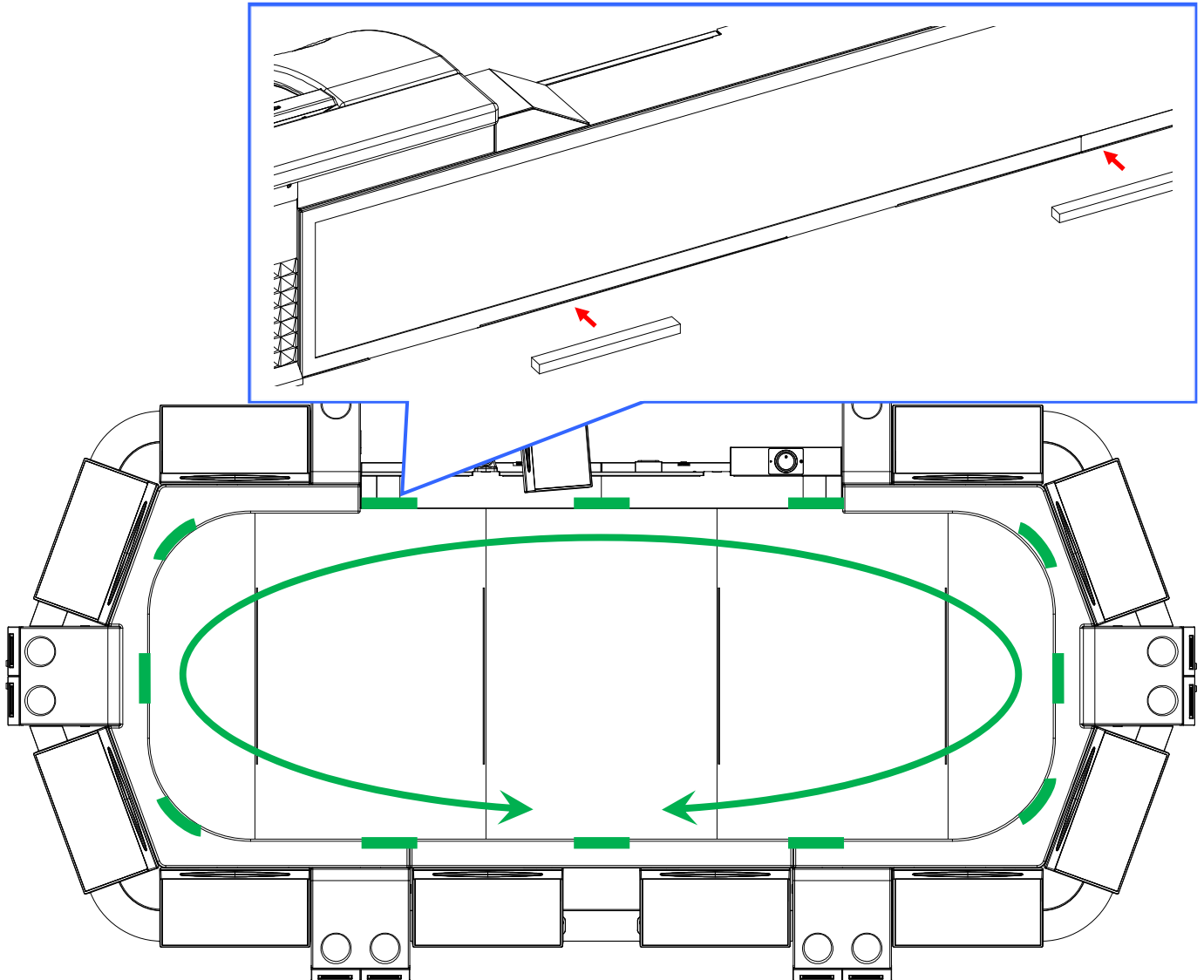

3. 2. 21: Installing the Dice tilt rubber

i NOTE: Option-9

By adding the Dice Tilt Rubber, it is possible to reduce slanted Dice.

Option-9

1. Prepare the following Parts.

Parts Name	Qty	Appearance
Dice Tilt Rubber	4	

2. While peeling the release paper of the double coated adhesive tape of the Dice Tilt Rubber, stick it along bottom edge of the wall, so that no gap remains between that and Field.

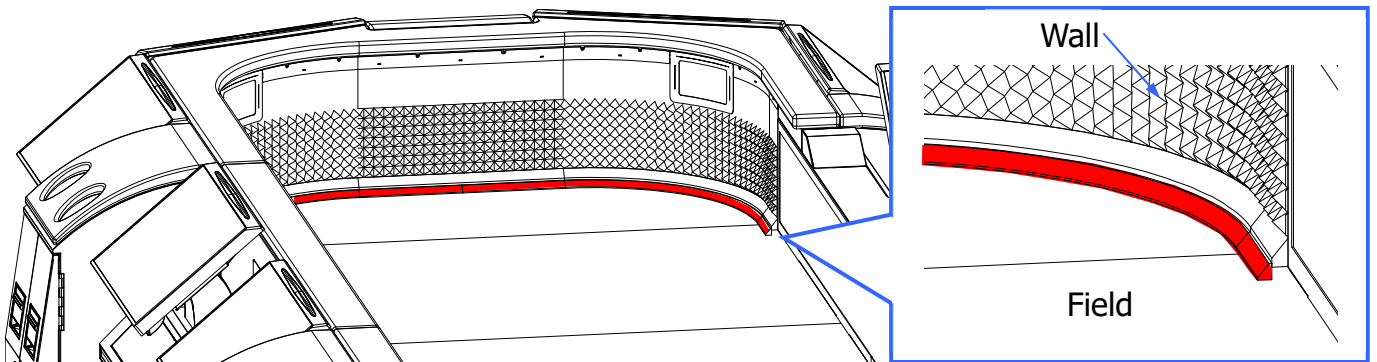

3. In the same way, stick it to the opposite side as well.

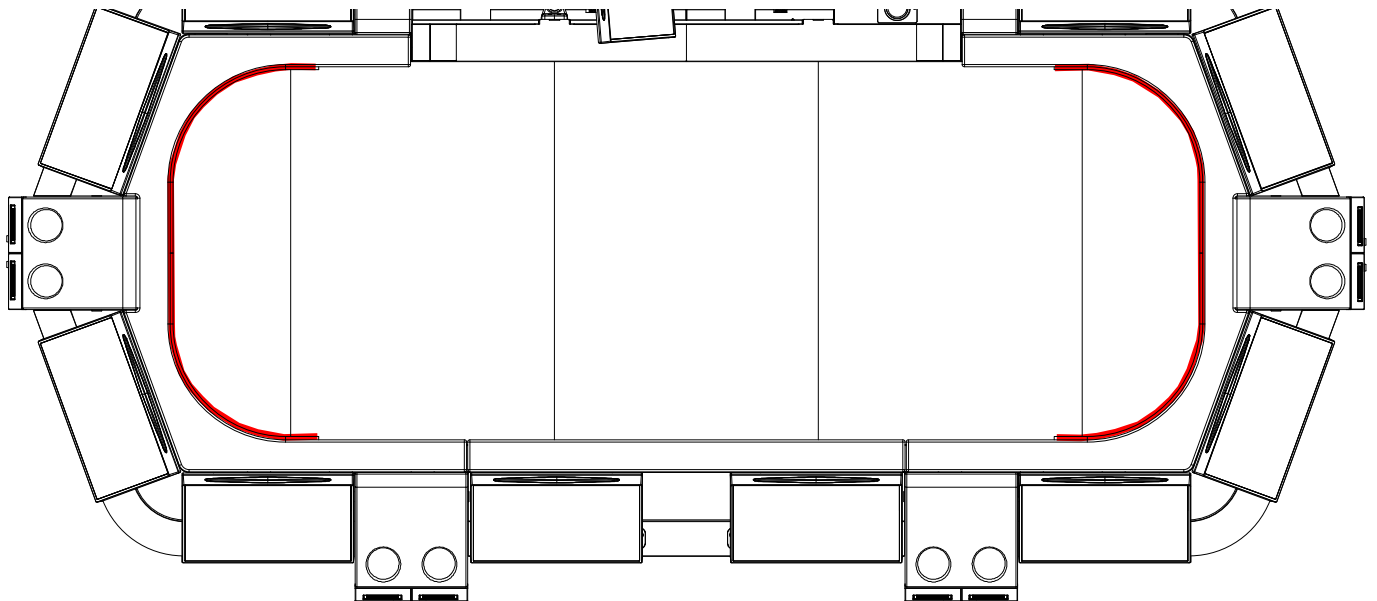

3. 2. 22: Installing the Player Partition Unit

i NOTE: Option-10

The areas of adjacent players can be partitioned.

Option-10

1. Prepare the following Parts.

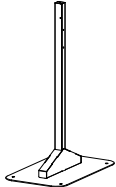
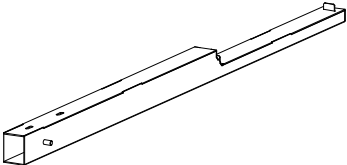
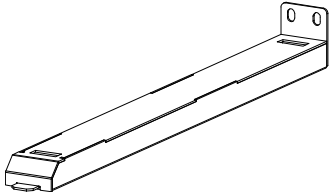
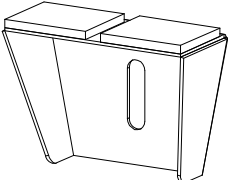
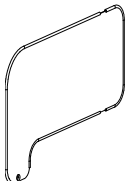
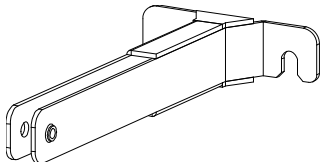
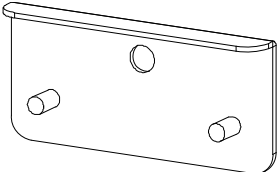
Parts Name	Qty	Appearance
Player Partition Base	1	
Player Partition BRKT A	1	
Player Partition BRKT B	1	
Player Partition Fix BRKT	1	
Player Partition	1	
Player Partition Holder A	1	
Player Partition Holder B	1	

2. Insert the Partition BRKT A inside the Partition Base, and affix it from both sides by using 4 screws.

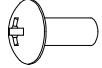
Fasteners		Qty	Appearance
Bg	TRUSS M4x10 GLD	4	

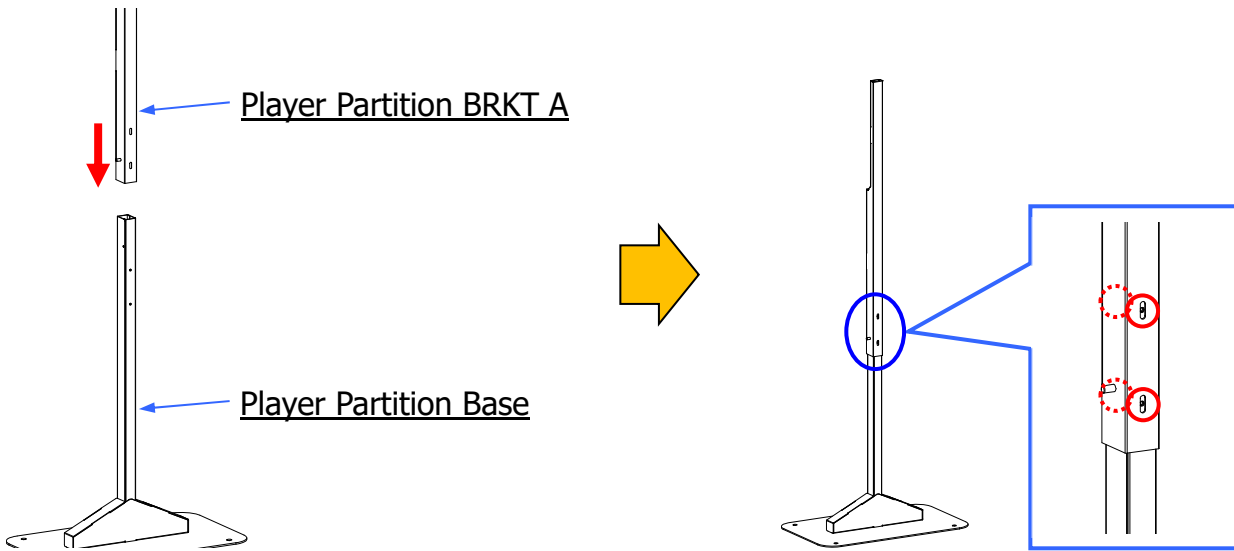

3. Temporary affix the Partition Fix BRKT to the Partition BRKT A by using the nut.

Fasteners		Qty	Appearance
AZ	WING NUT M6	1	

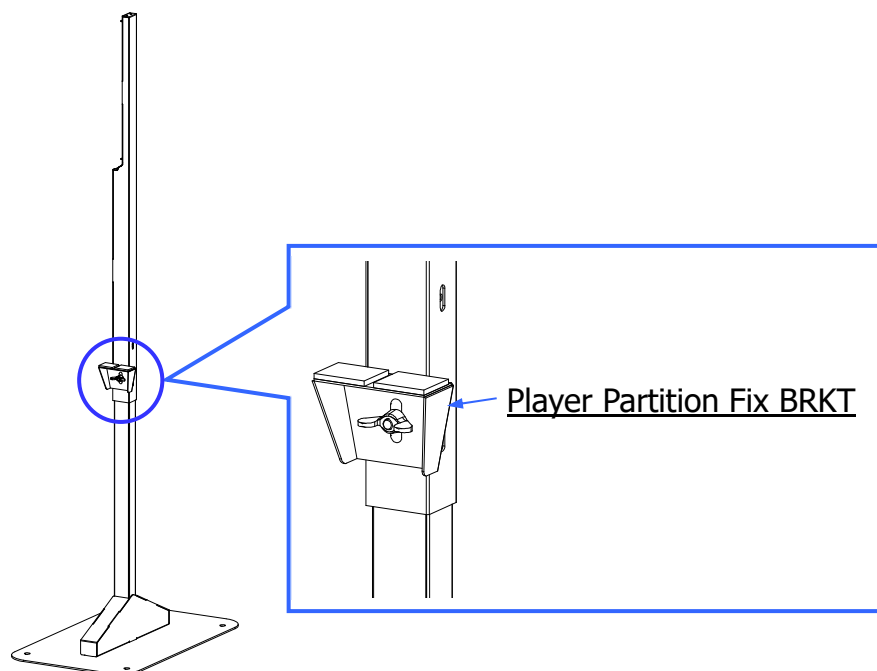

4. Insert the Partition BRKT A in the Partition BRKT B, place the Player Partition between the BRKT A and the BRKT B, then affix the upper part of the BRKT by using 2 screws.

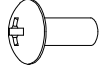
Fasteners		Qty	Appearance
Bg	TRUSS M4x10 GLD	2	

i NOTE:

Refer to the measurement illustrated in the image below then, after the Player Partition is correctly positioned, secure it on the 2 Guide Plates on the BRKT A.

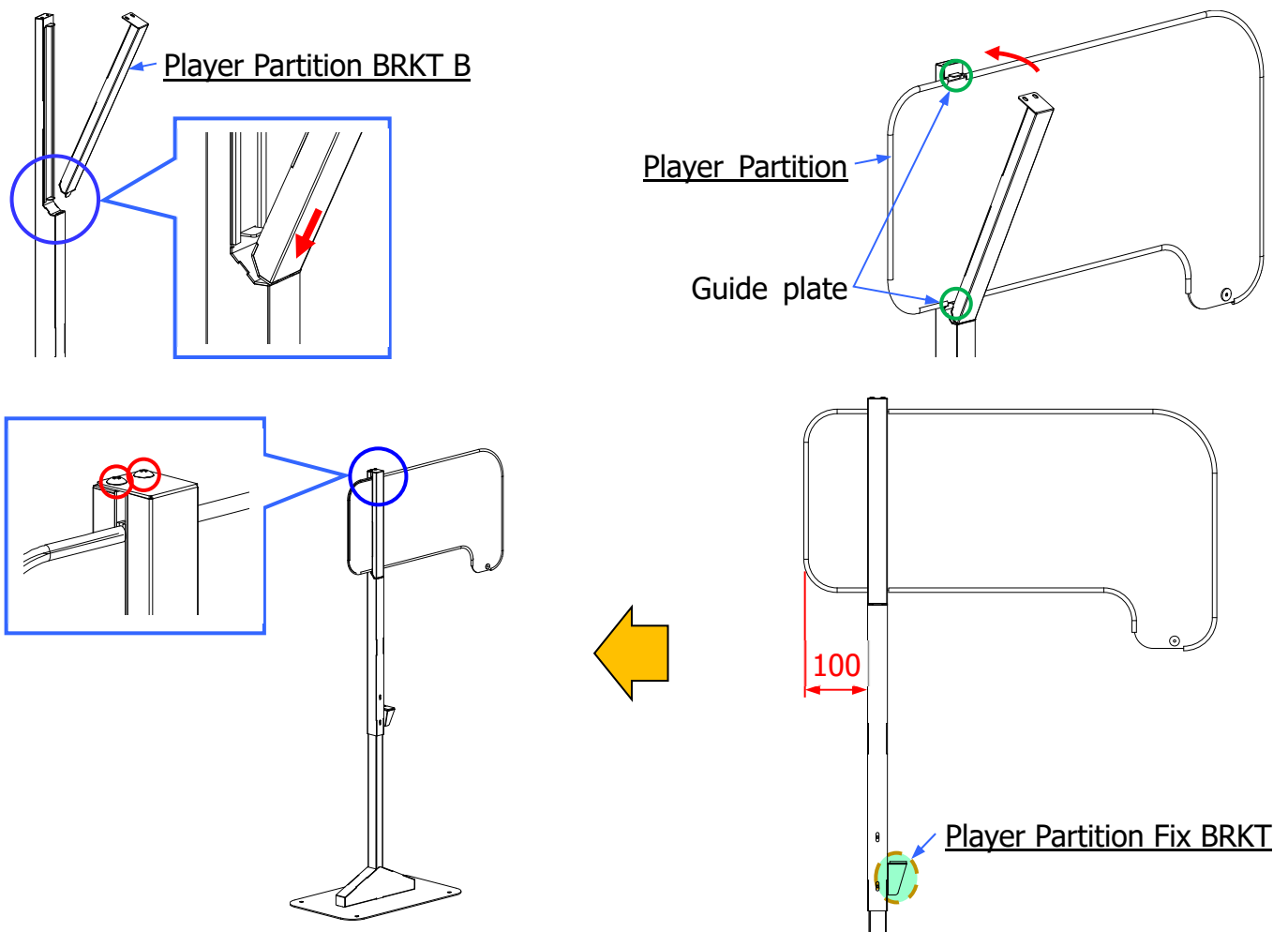

5. Remove the 1 screw illustrated below, and use that removed screw to affix the Partition Holder B.

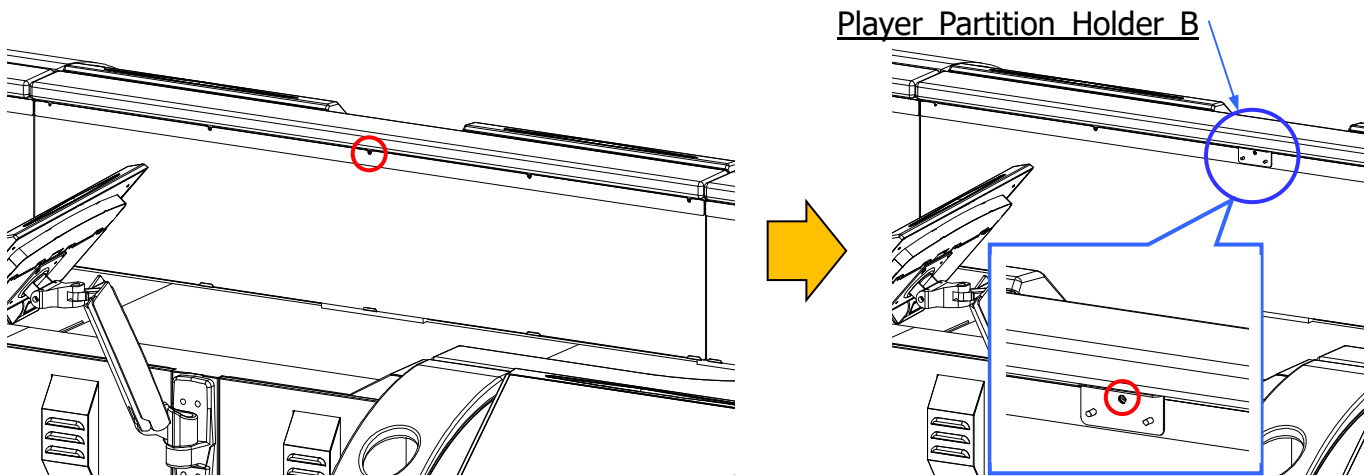

6. Affix the Partition Holder A to the Partition Holder B by using 2 nuts.

Fasteners		Qty	Appearance
Rb	FLANGE NUT M4 BLK	2	

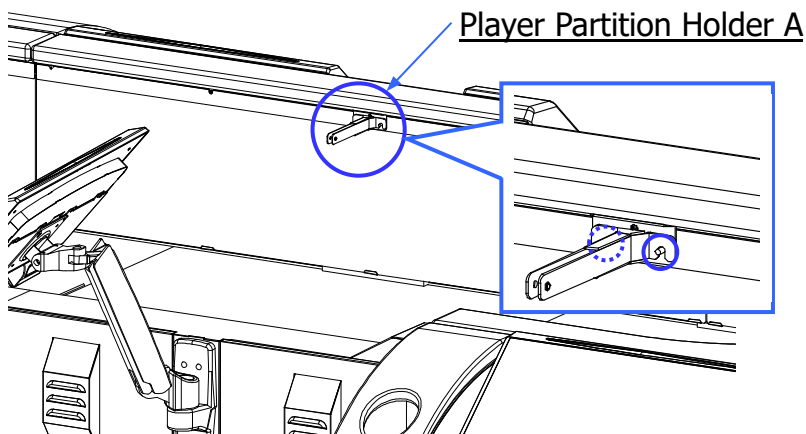

7. Insert the Player Partition Unit inside the Partition Holder A, then affix the Player Partition Unit by putting a screw through it.

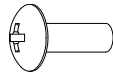
Fasteners		Qty	Appearance
C	TRUSS M4x12	1	

i NOTE:

Install the Partition without apply excessive force nor distorting it.

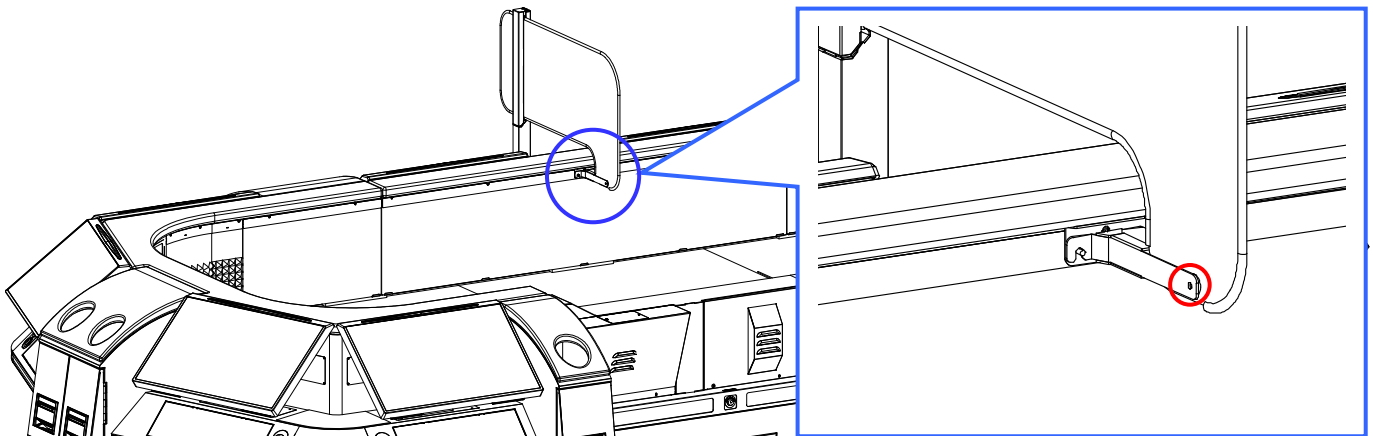

8. Last, adjust the height of the Partition Fix BRKT that was installed at step 3, and make it adhere to the Machine.

i NOTE:

If necessary, affix the Partition Base to the floor.

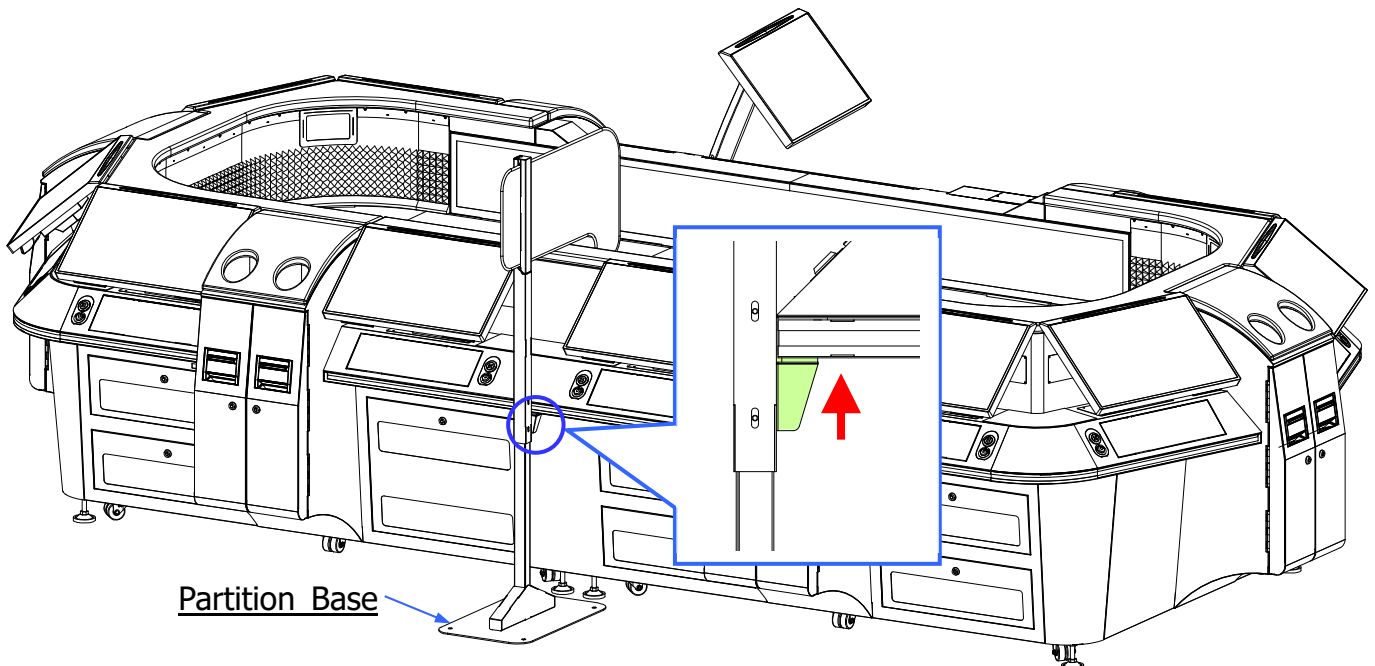

3. 2. 23: Installing the Dealer Partition Unit

i NOTE: Option-11

The area of the Dealer can be partitioned.

Option-11

1. Prepare the following Parts.

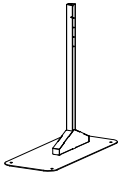
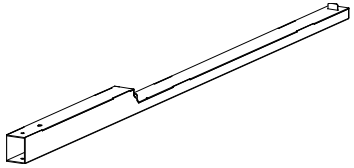
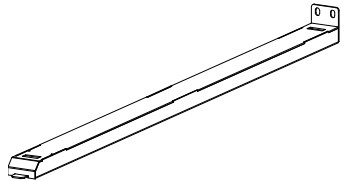
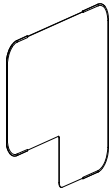
Parts Name	Qty	Appearance
Dealer Partition Base	2	
Dealer Partition BRKT A	2	
Dealer Partition BRKT B	2	
Dealer Partition	2	

- Insert the Partition BRKT A inside the Partition Base while paying attention to its direction, and affix it from both sides by using 4 screws.

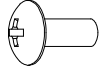
Fasteners		Qty	Appearance
Bg	TRUSS M4x10 GLD	4	

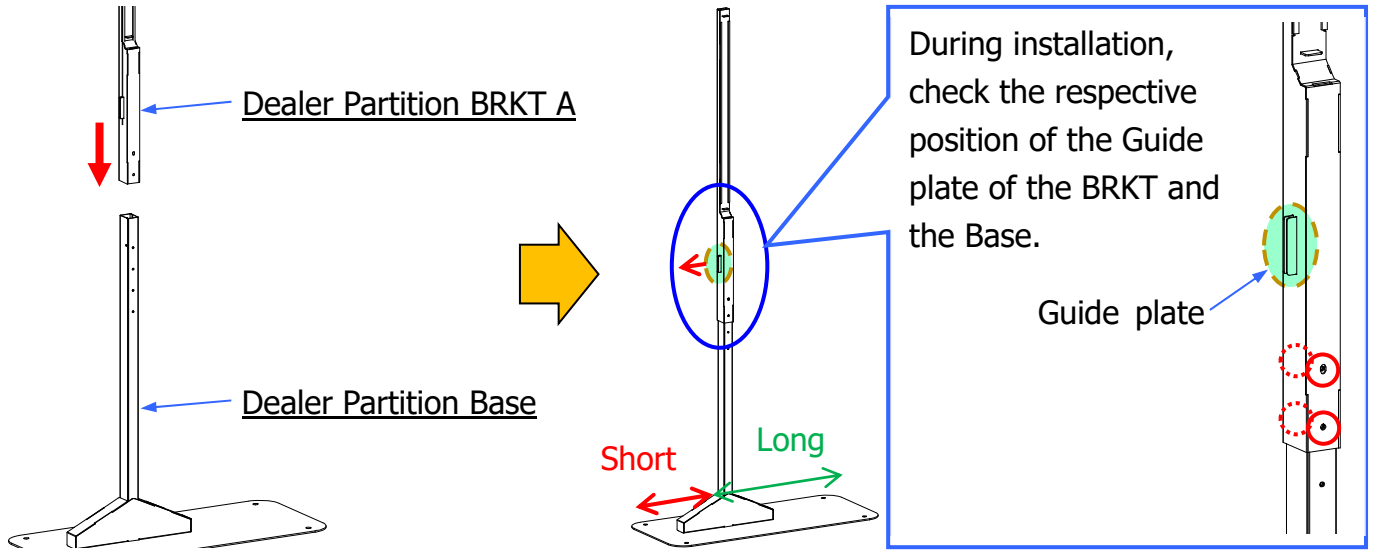

3. Insert the Partition BRKT A in the Partition BRKT B, place the Dealer Partition between the BRKT A and the BRKT B, then affix the upper part of the BRKT by using 2 screws.

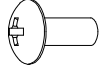
Fasteners		Qty	Appearance
Bg	TRUSS M4x10 GLD	2	

i NOTE:

After the Dealer Partition is correctly positioned, secure it on the 3 Guide Plates on the BRKT A.

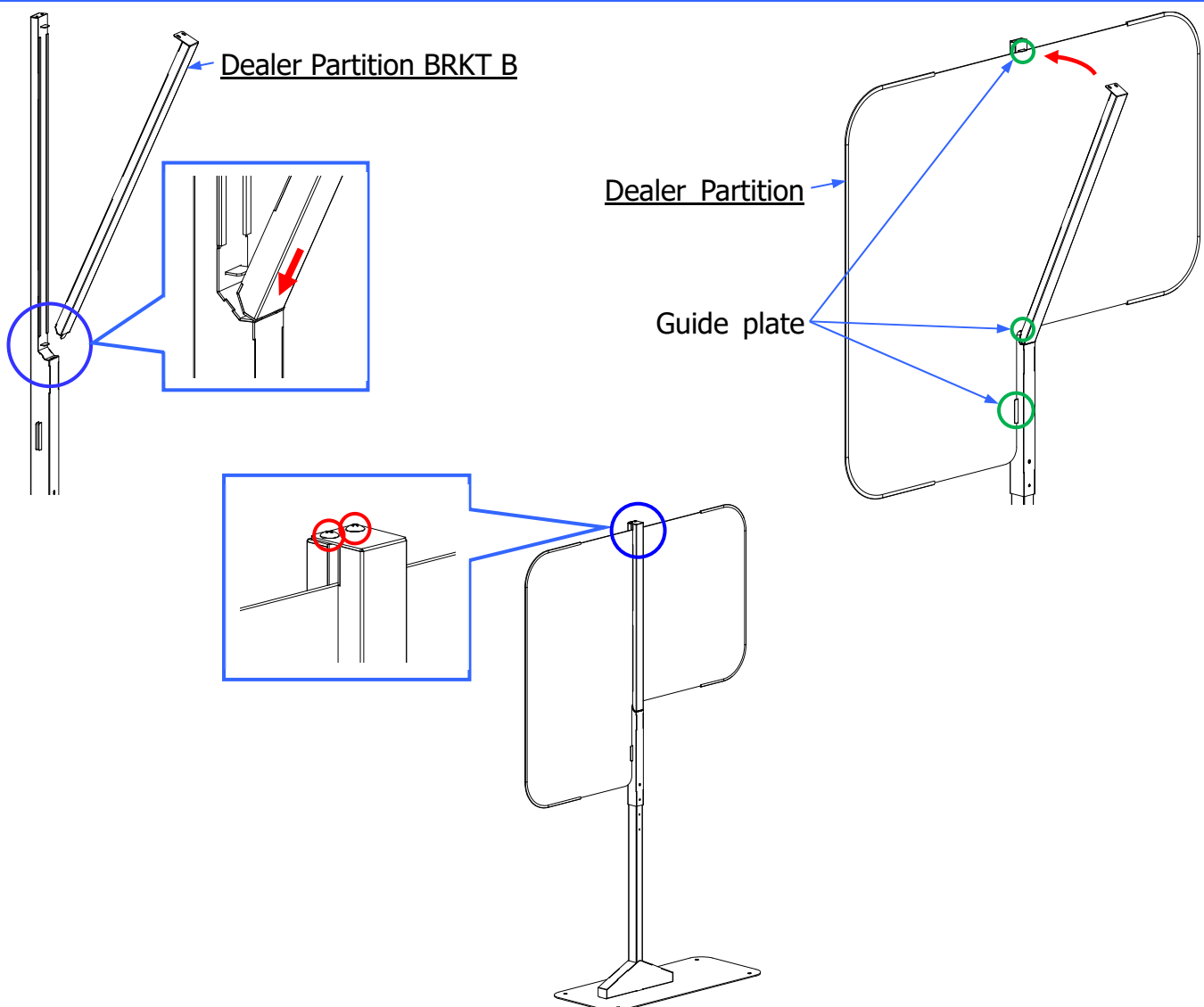

4. Prepare a set of 2 Dealer Partition Units, and refer to the image to install them to the machine.

i NOTE:

If necessary, affix the Partition Base to the floor.

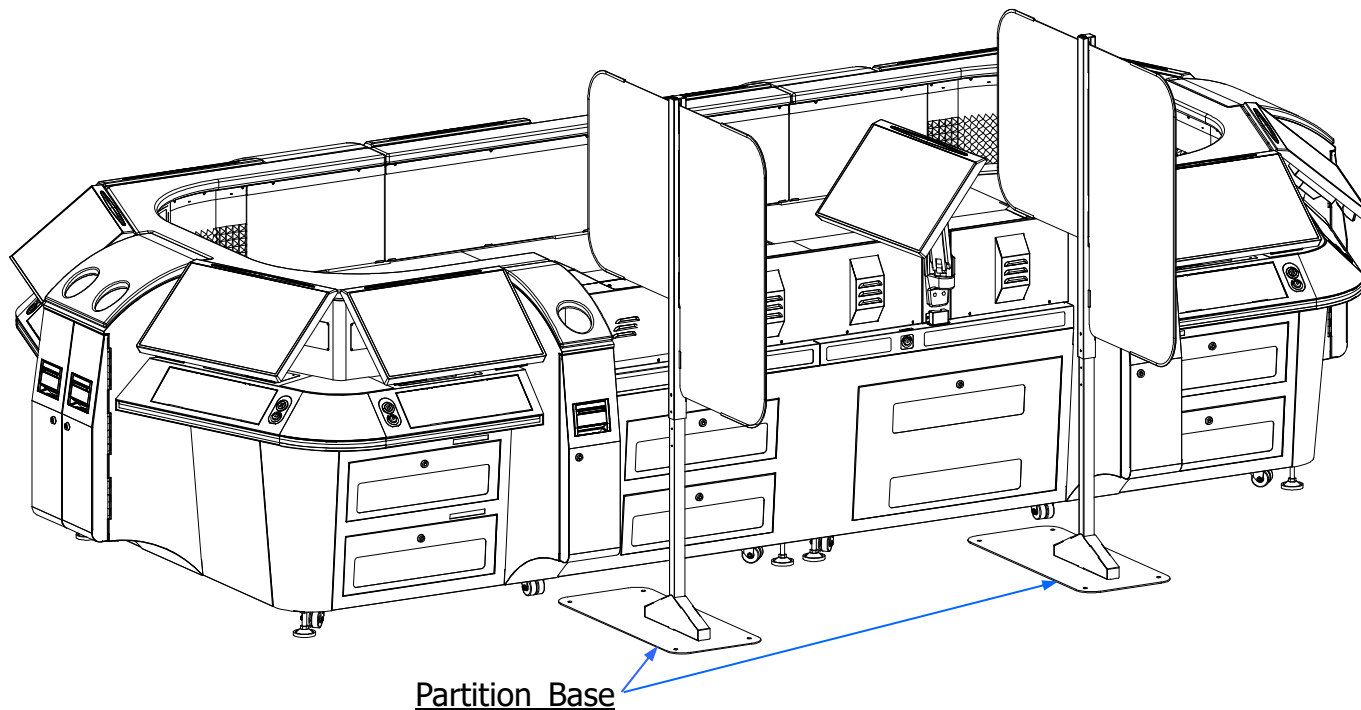

This completes the operations.

Chapter 4

Machine Specifications

4. 1: Cabinet Code(MODEL#)

Center Unit: RTWC-MS

Controller Unit (Main / Signage / Station): SYSX-BT

4. 2: Overall Dimension

	Width	Height	Depth
Center Unit	4119 mm (162.17")	1023 mm (40.28")	2094 mm (82.44")
History Display Unit Excluding Tower Light (Option)	750 mm (29.53")	450 mm (17.72")	2099.8 mm (82.67")

4. 3: Weight

Center Unit	1694 kg(3734.6 lbs)
History Display Unit	73 kg(160.9 lbs)

4. 4: Electrical Specifications

Center Unit: RTWC-MS

Power Requirements

[SW1]

Input Voltage	100 - 120VAC	220 - 240VAC
Input Frequency	50 / 60Hz	50 / 60Hz
Mains Input Current		
EGM Maximum (* Including Service Outlet)	6.3 A	3.0 A
EGM Typical	4.6 A	2.3 A
Power Consumption at Nominal Voltage		
EGM Typical	444 W	444 W
Typical Heat Load	1515 BTU/hr	1515 BTU/hr
Maximum Load Current		
Service Outlet	N/A	N/A
Power Consumption at Nominal Voltage		
EGM Maximum (excluding Service Outlet)	Maximum allowed by PSU	Maximum allowed by PSU

[SW2]

Input Voltage	100 - 120VAC	220 - 240VAC
Input Frequency	50 / 60Hz	50 / 60Hz
Mains Input Current		
EGM Maximum (* Including Service Outlet)	8.0 A	3.6 A
EGM Typical	3.0 A	1.5 A
Power Consumption at Nominal Voltage		
EGM Typical	308 W	307 W
Typical Heat Load	1051 BTU/hr	1048 BTU/hr
Maximum Load Current		
Service Outlet	N/A	N/A
Power Consumption at Nominal Voltage		
EGM Maximum (excluding Service Outlet)	Maximum allowed by PSU	Maximum allowed by PSU

[SW3]

Input Voltage	100 - 120VAC	220 - 240VAC
Input Frequency	50 / 60Hz	50 / 60Hz
Mains Input Current		
EGM Maximum (* Including Service Outlet)	8.5 A	4.1 A
EGM Typical	6.3 A	3.1 A
Power Consumption at Nominal Voltage		
EGM Typical	499 W	479 W
Typical Heat Load	1703 BTU/hr	1635 BTU/hr
Maximum Load Current		
Service Outlet	N/A	N/A
Power Consumption at Nominal Voltage		
EGM Maximum (excluding Service Outlet)	Maximum allowed by PSU	Maximum allowed by PSU

[Field LED] x 4

Input Voltage	100 - 120VAC	220 - 240VAC
Input Frequency	50 / 60Hz	50 / 60Hz
Mains Input Current		
EGM Maximum (* Including Service Outlet)	10.2 A	5.1 A
EGM Typical	6.9 A	3.6 A
Power Consumption at Nominal Voltage		
EGM Typical	757 W	727 W
Typical Heat Load	2584 BTU/hr	2481 BTU/hr
Maximum Load Current		
Service Outlet	N/A	N/A
Power Consumption at Nominal Voltage		
EGM Maximum (excluding Service Outlet)	Maximum allowed by PSU	Maximum allowed by PSU

[Wall LED]

Input Voltage	100 - 120VAC	220 - 240VAC
Input Frequency	50 / 60Hz	50 / 60Hz
Mains Input Current		
EGM Maximum (* Including Service Outlet)	4.7 A	2.3 A
EGM Typical	3.5 A	1.9 A
Power Consumption at Nominal Voltage		
EGM Typical	392 W	381 W
Typical Heat Load	1338 BTU/hr	1300 BTU/hr
Maximum Load Current		
Service Outlet	N/A	N/A
Power Consumption at Nominal Voltage		
EGM Maximum (excluding Service Outlet)	Maximum allowed by PSU	Maximum allowed by PSU

History Display Unit

Power Requirements

Input Voltage	100 - 120VAC	220 - 240VAC
Input Frequency	50 / 60Hz	50 / 60Hz
Mains Input Current		
EGM Maximum (* Including Service Outlet)	1.3 A	0.7 A
EGM Typical	0.9 A	0.5 A
Power Consumption at Nominal Voltage		
EGM Typical	109 W	108 W
Typical Heat Load	372 BTU/hr	369 BTU/hr
Maximum Load Current		
Service Outlet	N/A	N/A
Power Consumption at Nominal Voltage		
EGM Maximum (excluding Service Outlet)	Maximum allowed by PSU	Maximum allowed by PSU

4. 5: Environment

Ambient temperature	0 through 40 degrees C
Ambient humidity	5 through 95% Free from dew condensation

4. 6: BILLS Capacity

Maker : Model	Capacity
JCM : UBA / i VIZION / i PRO	500 – 900 BILLS
Cash Code : CASH CODE ONE	600 – 900 BILLS
MEI : CASHFLOW	600 – 1200 BILLS



Customer Technical Support Available 24 hours a day/ 7 days a week

TEL: USA, Canada, Latin America, Asia-Pacific: +1 877 676 7711
Europe, Middle East and Africa: +386 51 305 111
FAX: +386 1 724 77 44
EMAIL: call.center@interblockgaming.com
WEB: www.interblockgaming.com/service

Australia

Interblock Asia & Pacific Pty Ltd

World Square Tower' Suite 4555 Level 45, 680 George Street, Sydney NSW 2000

Canada

Interblock Canada Inc.

#225 - 20316 56 Avenue, Langley, British Columbia, Canada V3A 3Y7

Asia

Interblock Asia Pacific Pty Ltd – Macau Branch

Avenida da Praia Grande, n. 325, Edificio Cheong Fai, 2 andar "B", Macau

USA

Interblock Usa L.C.

6900 S Decatur Blvd. Suite 100, Las Vegas, NV 89118, USA

Latin America

Interblock Spain S.L. – Argentina Branch Regional Office Buenos Aires, Argentina

Esmeralda 1320, Piso 6° Of. B, Buenos Aires 1007, Argentina

Europe

Interblock D.O.O.

Gorenjska cesta 23, 1234 Mengeš, Slovenia, Europe

Japan

G.K. Interblock

TS Tower, 4-12-3 Higashi-Shinagawa, Shinagawa, Tokyo, 140-0002 Japan