

ROULETTE XPLOSION

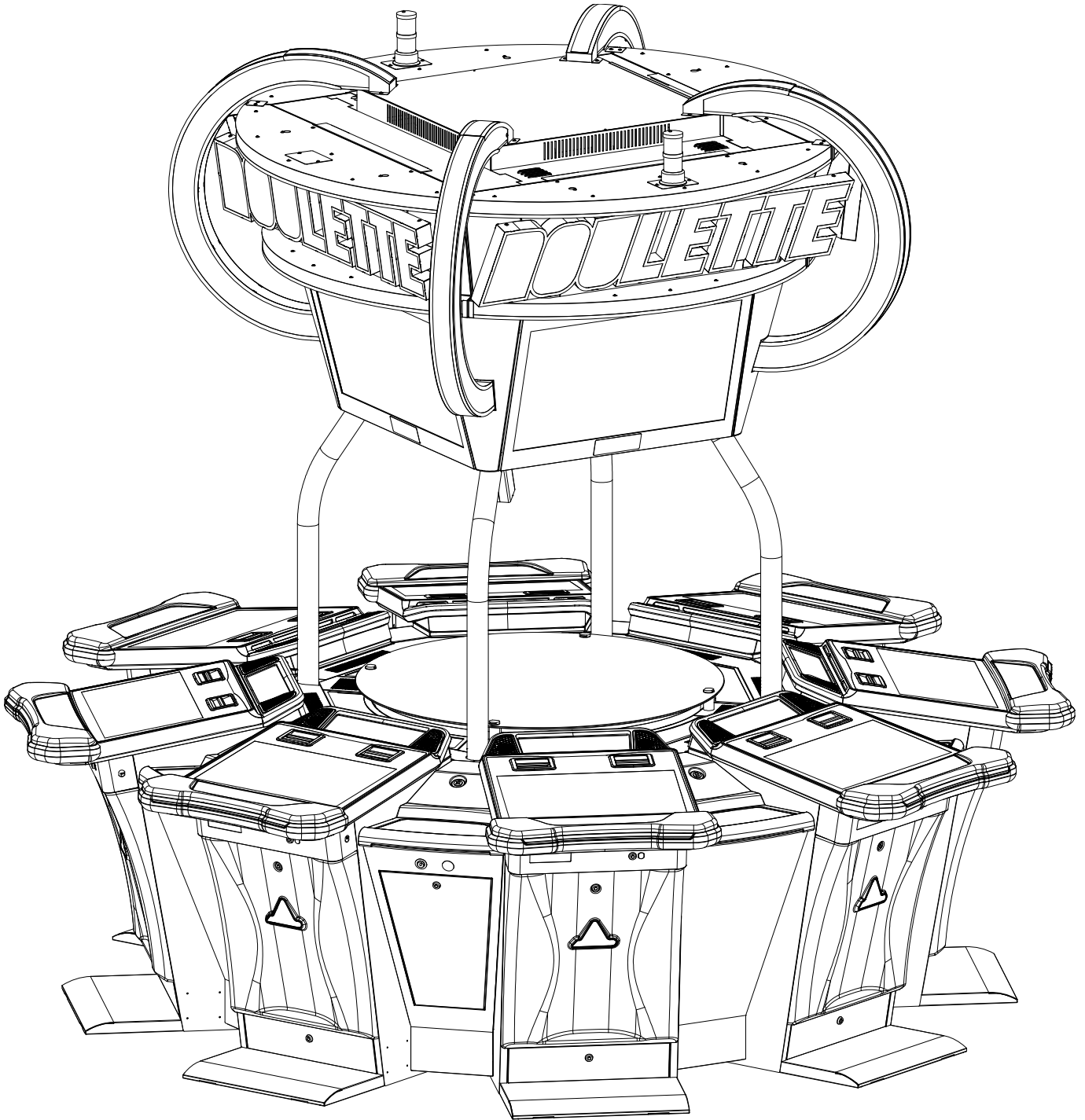

Important notice

ATTENTION!

It is necessary to periodically clean the Wheel Bank, Dice Field etc., according to the prescribed procedure.

It is also strongly recommended to replace the Ball (for Roulette), Clapper (pointer for Big Wheel or Wheel of Wealth) and Dice (for Sic Bo and Craps) if these items are suspected to have developed any abrasions or damage, and to replace these items when their defined usage period has expired.

Furthermore, if abnormal behavior of the machine is observed despite adherence to the prescribed maintenance procedures previously described, please immediately contact the Customer Technical Support or your Sales Representative/Representative Agent. Please notice that failure to adhere to the aforementioned prescribed procedures could result in machine trouble that may not be covered under the conditions of the guarantee.

For any questions regarding maintenance, machine check-up, or the expendable replacement parts, please contact the Customer Technical Support or your Sales Representative/Representative Agent in your area.

重要通知

Wheel Bank、Dice Field 等部件需要按照指定方法定期的进行清理。

除了因为磨损或者损坏进行更换以外，我们也非常建议您在使用了超出规定时间后，定期的更换小球(轮盘)，拍板，骰子(骰宝，花旗骰)等部件。

并且，当进行上述维护步骤时如果游戏机有任何异常时，请迅速与我们的营销人员，服务窗口，供应商取得联系。如果没有按照上述规定的步骤而引起游戏机发生任何的故障问题，不包含在保修之内。请见谅。

关于本公司游戏机的整備，点检以及消化品的交换，如果您有任何疑问，请联系我们的销售人员，服务窗口或者您所在区域的代理商。

Important notice during operation



ATTENTION!

Please fully understand the statement on this page, otherwise serious financial loss could be caused to the casino.

Please be aware that **a critical problem has occurred in the basic function of the machine and there is a high possibility that the problem could potentially cause serious financial loss to the casino** even if one of the following errors occurs only once.



CALL SERVICE IMMEDIATERY!

Immediately turn off the machine and please contact the Customer Technical Support or your nearest distributor even if one of the following errors occurs only once. All the errors are the result of monitoring by important machine control functions and are indicating that a critical problem has occurred on the machine.

Error messages: Power OFF.  CALL SERVICE IMMEDIATELY!	
GAME INIT ERROR	ZERO SENSOR DETECT ERROR
BALL START ERROR	ZERO SENSOR ERROR
BALL FALL ERROR	AROUND SENSOR ERROR
COMPRESSOR ERROR	ENCODER COUNT ERROR
BALL COUNT ERROR	POCKET SHUFFLE ERROR
MOTOR ERROR	WHEEL DIRECTION ERROR
POSITION SENSOR ERROR (REF0130)	WHEEL ORIGIN DETECT ERROR
POSITION SENSOR ERROR (REF0430)	
POSITION SENSOR ERROR (REF0730)	
POSITION SENSOR ERROR (REF1030)	



Safe Power OFF

i NOTE:

Automatically turns POWER OFF the machine after all the data is correctly saved (Standby shutdown) just by an AUDIT operation, without using the Power Switch. **(Refer to "Shutdown" at Chapter 4 of Chapter 5 of the SERVICE Manual.)**

A. Turn off the Center Unit

[From the operating state]

1. Remove the Control Spacer Door, then press the [GAME SCREEN] button of the PC Changer. Turn the RESET/AUDIT Key Switch to AUDIT and then return it to neutral to enter AUDIT mode.

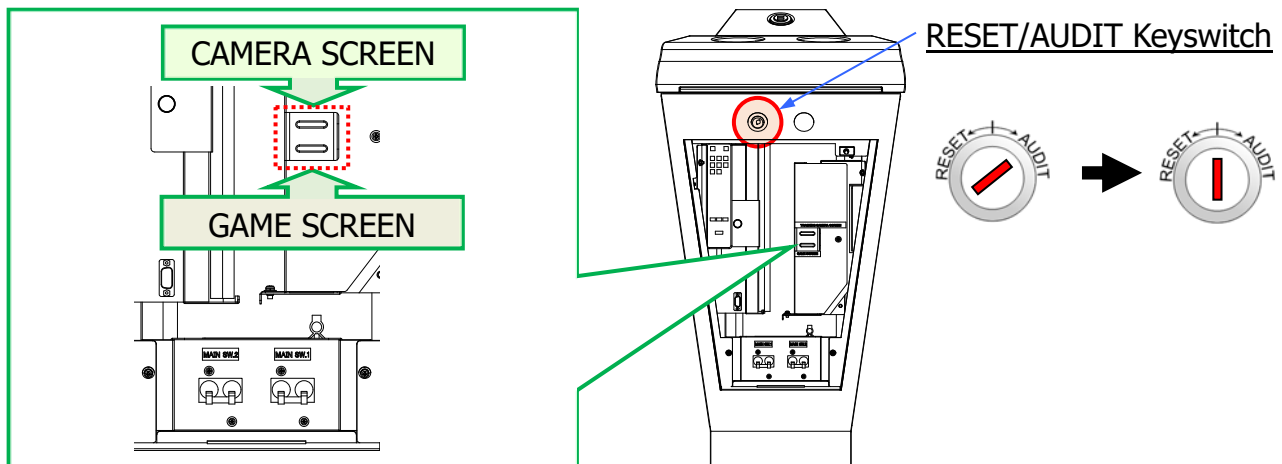

2. Select TOP MENU>SHUTDOWN, then press the [SHUTDOWN] Button displayed on the screen to put on standby shutdown the Center Unit.

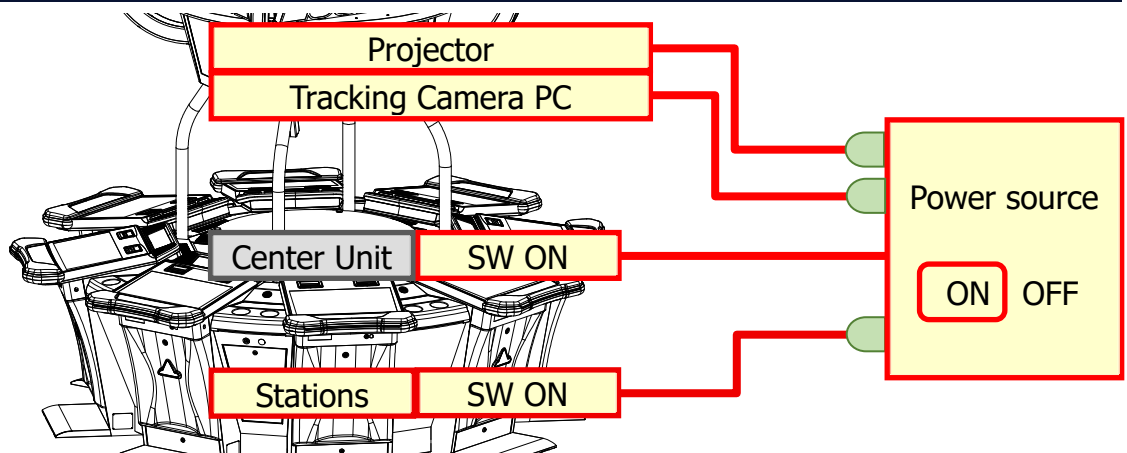

i NOTE:

[For immediate reboot after the standby shutdown]

Turn OFF and ON the Power Switch of the Center Unit. Then, close all the doors that were opened.

- When doing "Power OFF-ON" wait at least 15 seconds before power On.
- Do not turn ON the 2 Power switches at the same time. Doing so can result in a start-up error of the machine.

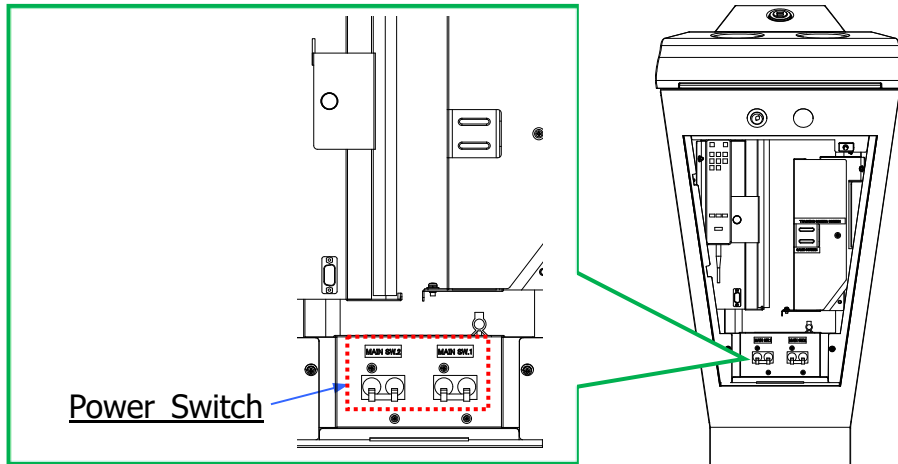

[For complete shutdown after the Standby shutdown] NOT standby shutdown

Turn OFF the Power Switch of the Center Unit.

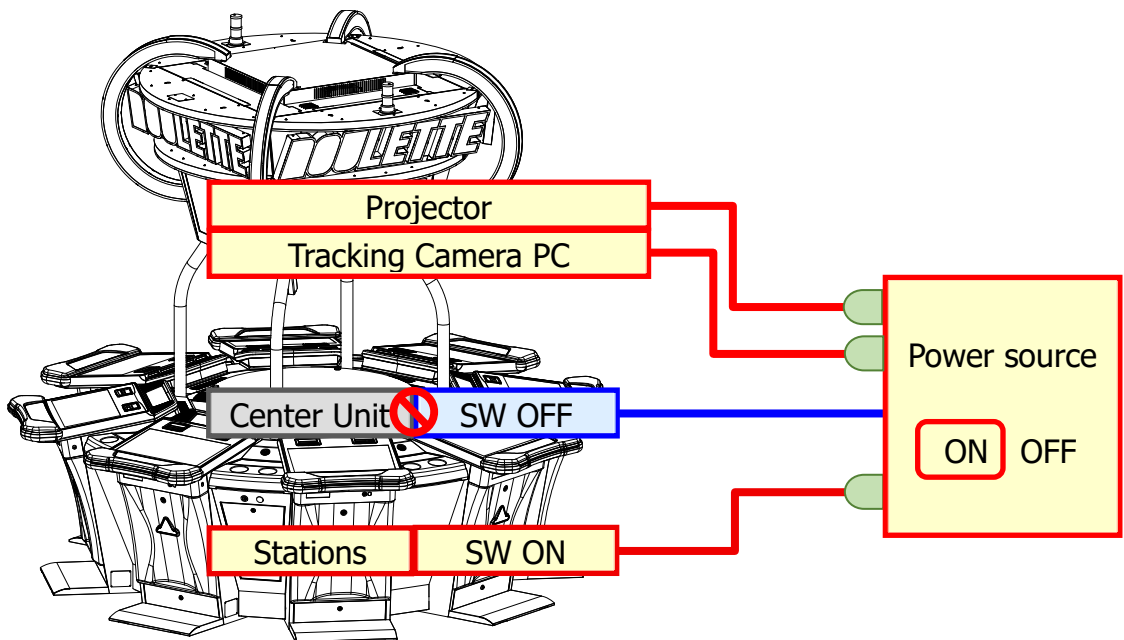

B. Turn off the Station

[From the operating state]

1. Remove the Front Door of the Station. Turn the RESET/AUDIT Key Switch to AUDIT and then return it to neutral to enter AUDIT mode.

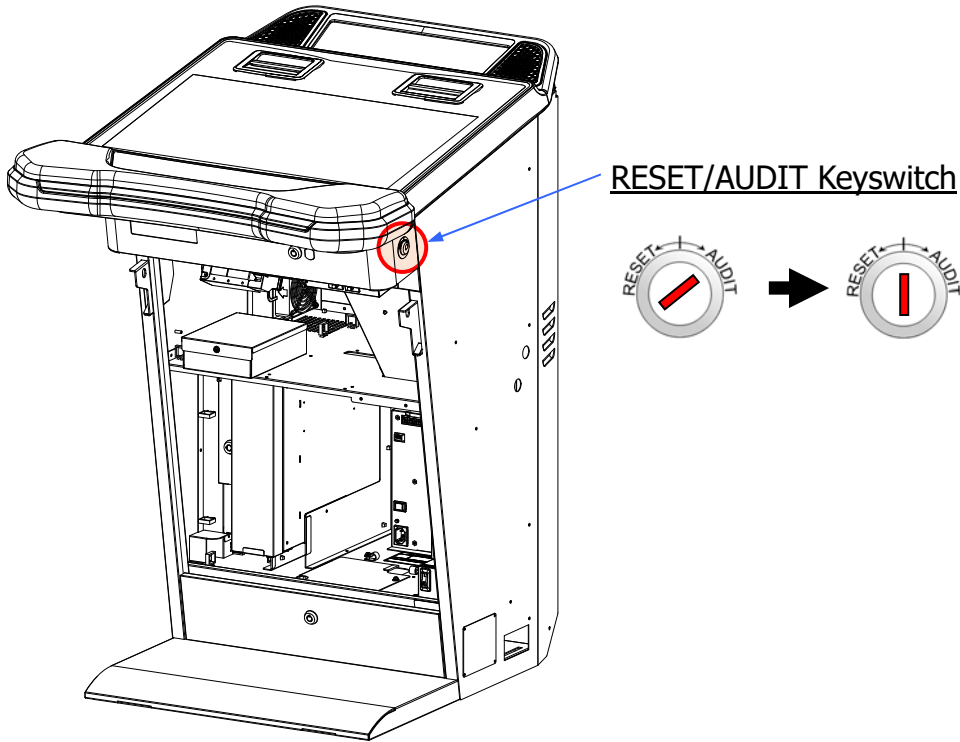

2. Select TOP MENU>SHUTDOWN, then press the [SHUTDOWN] Button displayed on the screen to put on standby shutdown the Station.

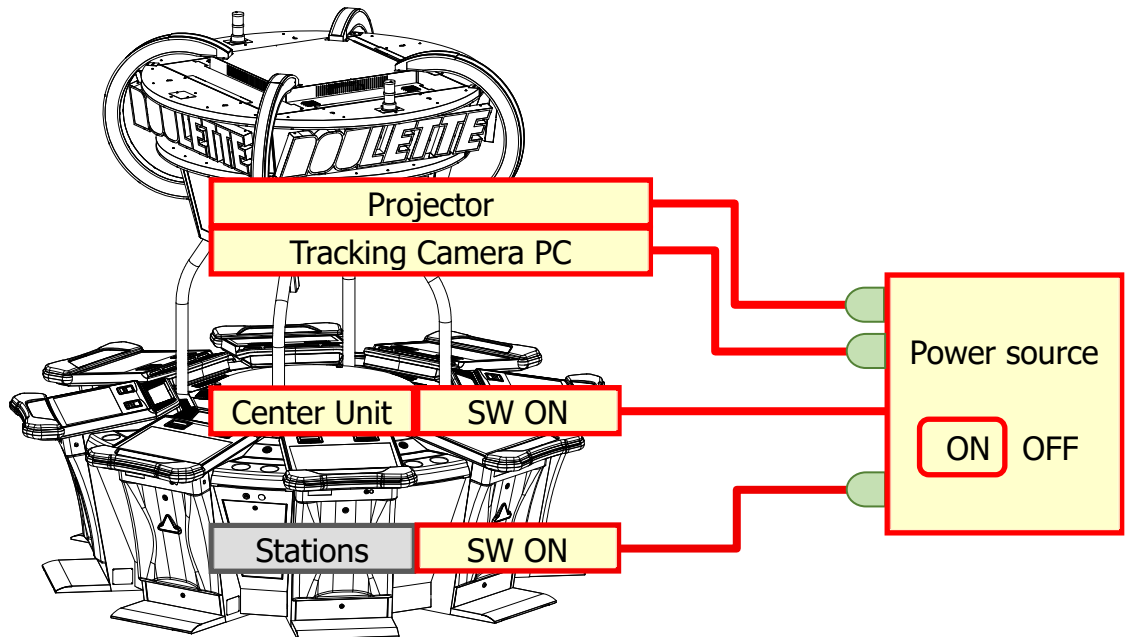

i NOTE:

[For immediate reboot after the standby shutdown]

Turn OFF and ON the Power Switch of the Station. Then, close all the doors that were opened.

·When doing "Power OFF-ON" wait at least 15 seconds before power On.

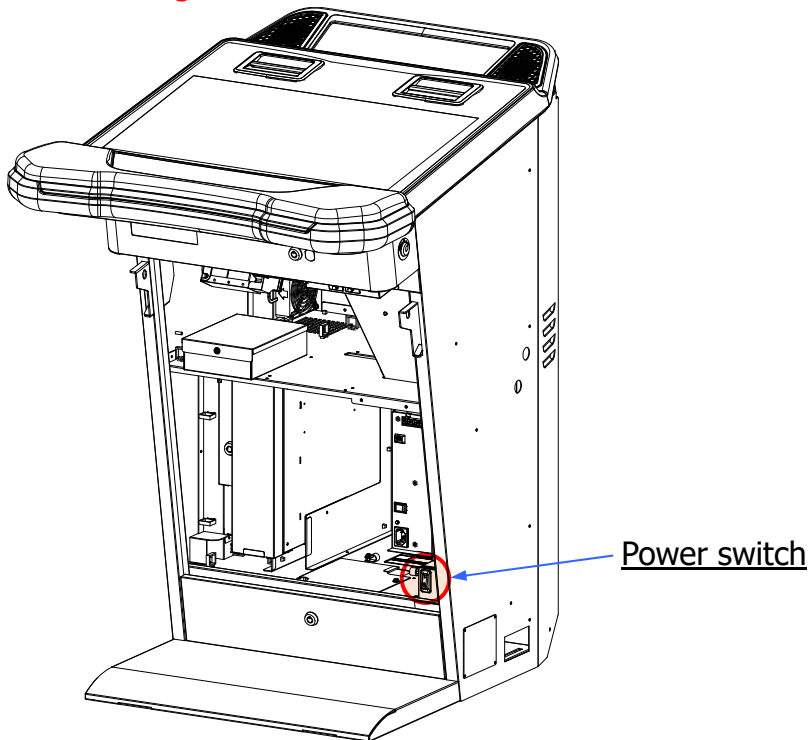

[For complete shutdown after the Standby shutdown] NOT standby shutdown

Turn OFF the Power Switch of the Station.

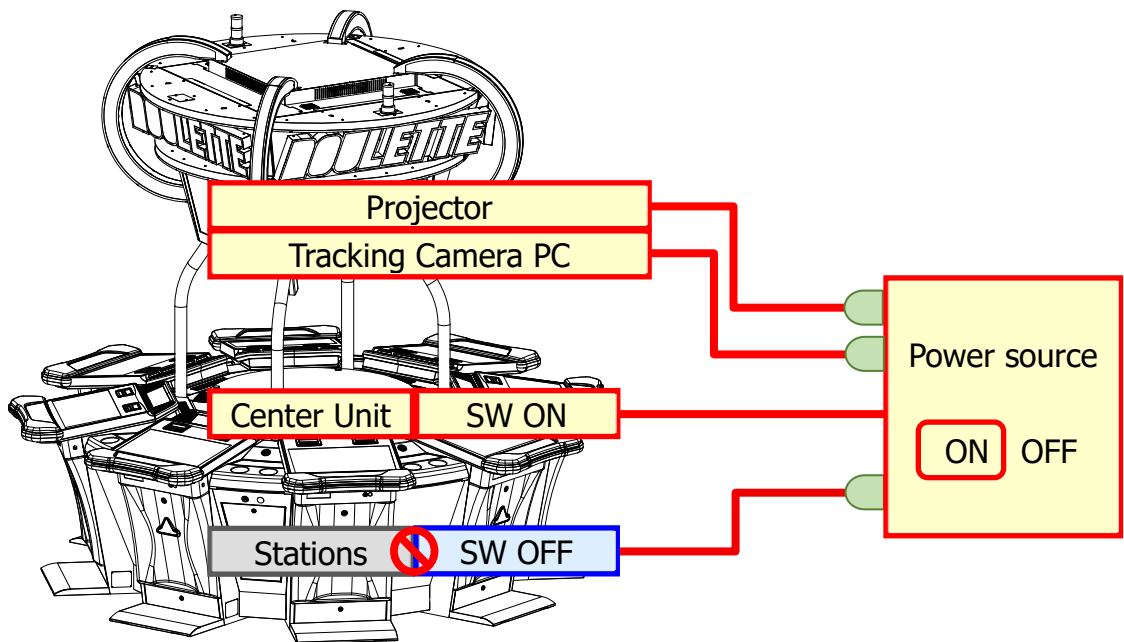

Table of Contents

	Page
General Information	
Introduction _____	1
Technical Support _____	1
Copyright _____	1
Safety Instructions	
Definition of Safety Vocabulary _____	2
Installation _____	3
Replacement of Lithium Batteries _____	3
Disposal of Lithium Batteries _____	3
Environmental Specifications _____	4
Grounding _____	4
Others _____	4
 Chapter 1: Major Components	
1. 1 ___ Appearance of Whole Machine _____	1-1
1. 2 ___ Outside View of Center Unit _____	1-2
1. 3 ___ Inside View of Center Unit _____	1-3
1. 4 ___ Outside View of Station _____	1-5
1. 5 ___ Inside View of Station _____	1-6
 Chapter 2: Unpacking and Inspection	
2. 1 ___ Unpacking and Inspection _____	2-1
 Chapter 3: Installation	
3. 1 ___ Cabinet Dimensions _____	3-1
3. 2 ___ Installing the Machine _____	3-2
3. 2. 1 ___ Center Unit _____	3-4
3. 2. 1. 1 ___ Installing the Center Unit _____	3-4
3. 2. 1. 2 ___ Assembling the Tracking Camera PC Unit _____	3-5
3. 2. 1. 3 ___ Assembling the Top Base Unit _____	3-7
3. 2. 1. 4 ___ Installing the Top Base Unit onto the Center Unit _____	3-14
3. 2. 1. 5 ___ Preparing the Sign Unit(Installing Tower Light) _____	3-30
3. 2. 1. 6 ___ Installing the Sign Unit(with Tower) onto the Top Base Unit _____	3-32
3. 2. 1. 7 ___ Installing the Sign Unit(No Tower) onto the Top Base Unit _____	3-41
3. 2. 1. 8 ___ Installing the Ring Units onto the Top Base Unit _____	3-49
3. 2. 1. 9 ___ Preparing the Monitor Unit _____	3-53
3. 2. 1. 10 ___ Installing the Monitor Unit onto the Top Base Unit _____	3-54

3. 2. 1. 11	___ Installing the Tracking Camera Unit _____	3-58
3. 2. 1. 12	___ Installing the Live Camera Unit _____	3-60
3. 2. 1. 13	___ Installing the Joint BRKT _____	3-62
3. 2. 1. 14	___ Connecting the Top Base Unit to the Center Unit _____	3-64
3. 2. 1. 15	___ Hardware Setting for Center Unit _____	3-70
3. 2. 1. 16	___ Connecting the Center Unit to the Power Source _____	3-74
3. 2. 1. 17	___ Preparation to install the Stations _____	3-76
3. 2. 1. 18	___ Attaching the Control Spacer Unit and the Drain Spacer Unit _____	3-78
3. 2. 1. 19	___ Installing the Control and Drain Spacer Units to Center Unit _____	3-81
3. 2. 1. 20	___ Activating the Air Compressor Unit and Projector Unit _____	3-88
3. 2. 1. 21	___ Checking Operation of the Center Unit – 1st Step _____	3-95
3. 2. 1. 22	___ Remove the Top Glass, Check the Machine and insert the Ball _____	3-99
3. 2. 1. 23	___ Checks during operation _____	3-102
3. 2. 1. 24	___ Checking Operation of the Center Unit – 2nd Step _____	3-103
3. 2. 1. 25	___ Installing the Monitor Bezel _____	3-106
3. 2. 2	___ Stations _____	3-108
3. 2. 2. 1	___ Attaching the Spacer Units for the other Stations _____	3-108
3. 2. 2. 2	___ Installing Other Stations and Connecting to Center Unit _____	3-110
3. 2. 2. 3	___ Hardware Setting for Station Unit _____	3-114
3. 2. 2. 4	___ Connecting the Stations to the Power Source _____	3-118
3. 2. 3	___ Checking and Setting _____	3-120
3. 2. 3. 1	___ Preparation to set the Stations _____	3-120
3. 2. 3. 2	___ Setting operation of Stations _____	3-122
3. 2. 3. 3	___ Verifying Operation of Whole Machine _____	3-125

Chapter 4: Machine Specifications

4. 1	___ Cabinet Code(MODEL#) _____	4-1
4. 2	___ Overall Dimension _____	4-1
4. 3	___ Weight _____	4-1
4. 4	___ Electrical Specifications _____	4-2
4. 5	___ Environment _____	4-3
4. 6	___ Bills Capacity _____	4-3

General Information

Introduction

This manual is intended to provide information regarding machine operation for operators, owners, and qualified maintenance/service personnel.

It is strongly recommended that this manual be read thoroughly before starting up the machine. Please keep this manual at hand to be used whenever necessary.

Technical Support

INTERBLOCK Luxury Gaming Products d.d., INTERBLOCK ASIA PACIFIC Pty Ltd, INTERBLOCK CASINO PRODUCTS CANADA Inc., INTERBLOCK ASIA PACIFIC Pty Ltd, INTERBLOCK USA L.C. are all dedicated to providing high quality service and maintenance. Please feel free to contact your local distributor office at any time. (See back page for contact listings)

Copyright

©2025 Interblock d.o.o. All rights reserved.

The information in this document is confidential. Reproduction in whole or in part on any medium without the express permission of Interblock d.d. is strictly prohibited.

This manual may be subject to change without prior notice.

Safety Instructions

Definition of Safety Vocabulary

The words DANGER, WARNING, and CAUTION are used in this manual to indicate hazard levels.

 **DANGER!**

The DANGER mark warns of immediate hazards, which WILL result in severe personnel injury or death.

 **WARNING!**

The WARNING mark warns of immediate hazards, which may result in severe personnel injury or death.

 **CAUTION!**

The CAUTION mark warns of hazards or unsafe practices, which may result in minor personnel injury or product/property damage.

 **CALL SERVICE IMMEDIATERY!**

This message implies that the operator is recommended to contact the Customer Technical Support. (See back page for contact listings.)

 **NOTE:**

The NOTE mark brings to attention important operation points.

Installation

WARNING!

To prevent an accident or a fire;

- ◇ Install the machine on flat, stable, well-constructed floor.
- ◇ Keep the machine away from direct sunlight.
- ◇ Keep the machine away from dust.
- ◇ Keep the machine away from water and other liquids.
- ◇ Do not install the machine outdoors.
- ◇ Keep the machine away from vibration.
- ◇ Keep the machine away from dangerous articles.
- ◇ Keep the machine away from disaster prevention facilities. (e.g. emergency exits/stairs, fire hydrants, fire extinguishers)
- ◇ **If the Projector is installed, please use the machine in an ambient with a temperature below 30°C. If the ambient temperature exceeds 30°C, the security function of the Projector may put it into a light off status.**

Replacement of Lithium Batteries

CAUTION!

Risk of Explosion.

When exchanging the lithium batteries, use an officially provided lithium battery.

Risk of Explosion if lithium battery is Replaced by an Incorrect type.

Disposal of Lithium Batteries

WARNING!

Risk of Injury or Fire.

Proper care is necessary with the disposal of lithium batteries. Improper disposal may result in the heating or ignition of the batteries, which may cause personal injury or fire. CR Coin Lithium Batteries contain Perchlorate material – special handling may apply.

Lithium batteries contain flammable substances (e.g. lithium metal and organic solvents). Electric power may remain in used batteries. Wrap the + and – electrodes with nonconductive material to prevent short-circuiting.

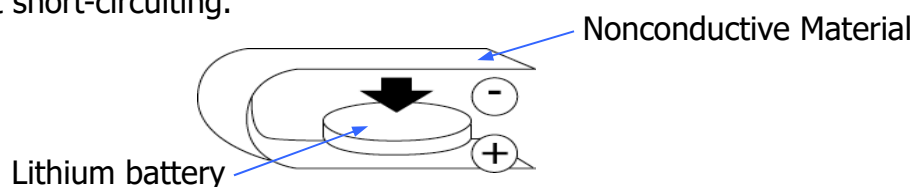

Environmental Specifications

Refer to "**Machine Specifications**".

Grounding

The machine must be grounded to prevent current leakage.

WARNING!

Risk of Electric Shock. The warranty is not valid for accidents (including failures) caused by improper grounding.

Others

WARNING!

The machine should never be modified in any way.

Modification may cause accident or failure.

The warranty is not valid for accidents (including failures) caused by modification.

- ◇ Only qualified personnel shall assemble, install, maintain, inspect, and/or enact any troubleshooting measures to the machine.
- ◇ Do not sit, stand or put heavy objects on the machine. A dented machine may cause malfunctioning.
- ◇ When smoke and/or an unknown malfunction is detected, immediately turn off the power switches and then turn off the power source breakers in that order.
- ◇ Before servicing the machine, turn off the power switches to prevent electricity-related accidents and hazards.
- ◇ Never use chemical dusters, paint thinner, benzene, alcohol, or synthetic detergent for cleaning the machine. Damage may be caused to the machine surface.
- ◇ Electrostatic discharges may damage the internal components of the machine. Anti-static measures (e.g. touching a metal door knob, use of non-static gloves) are necessary when accessing the inside of the cabinet.
- ◇ This machine is for use in commercial areas. Use in residential areas is prohibited.

Chapter 1

Major Components

1. 1: Appearance of Whole Machine

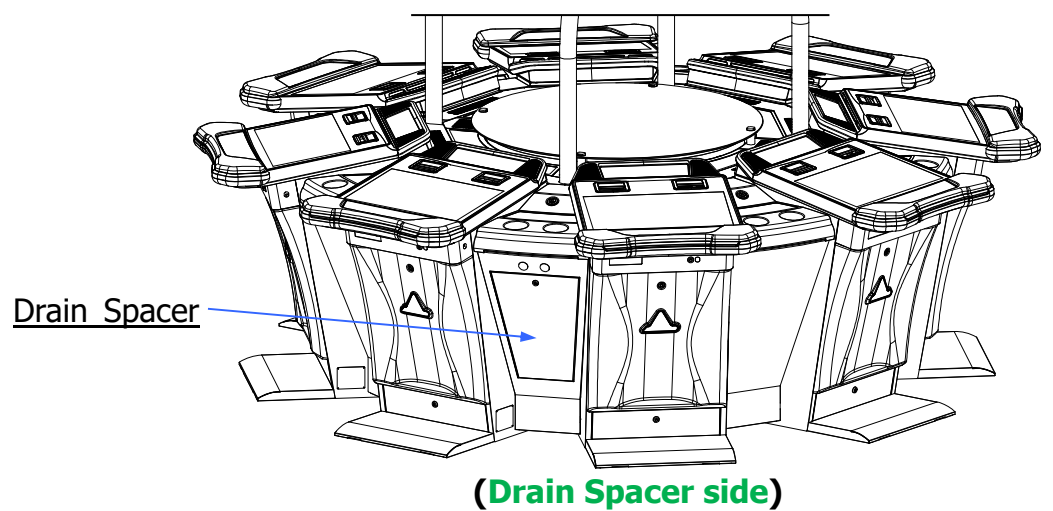
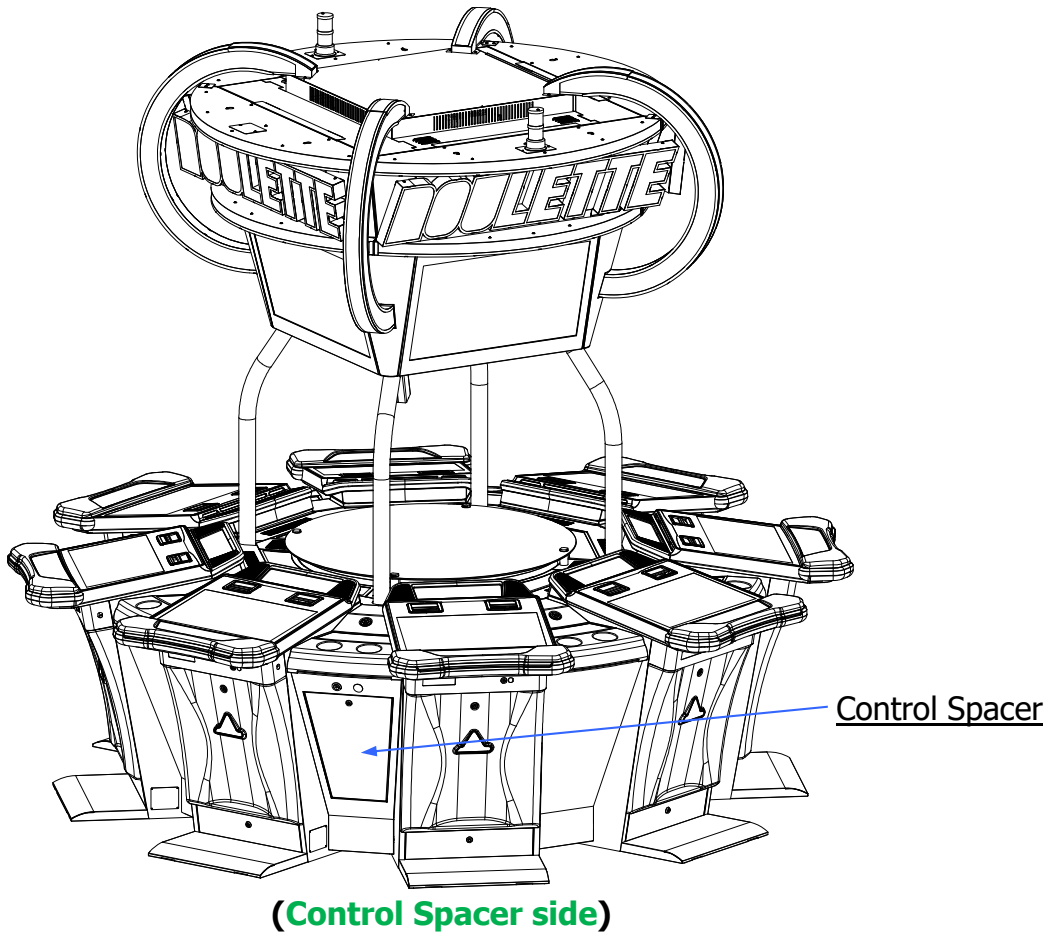

1. 2: Outside View of Center Unit

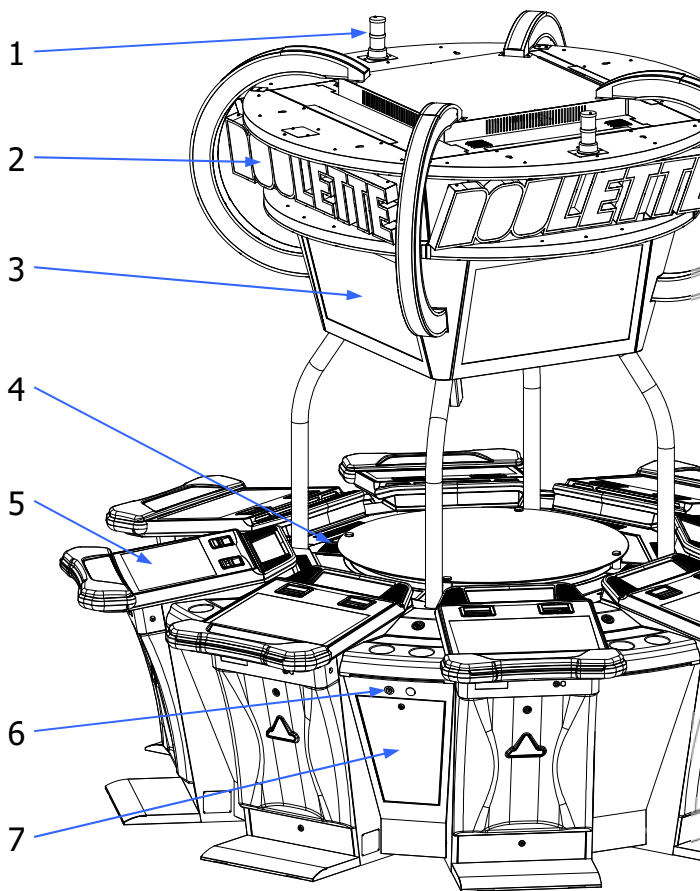

(Control Spacer side)

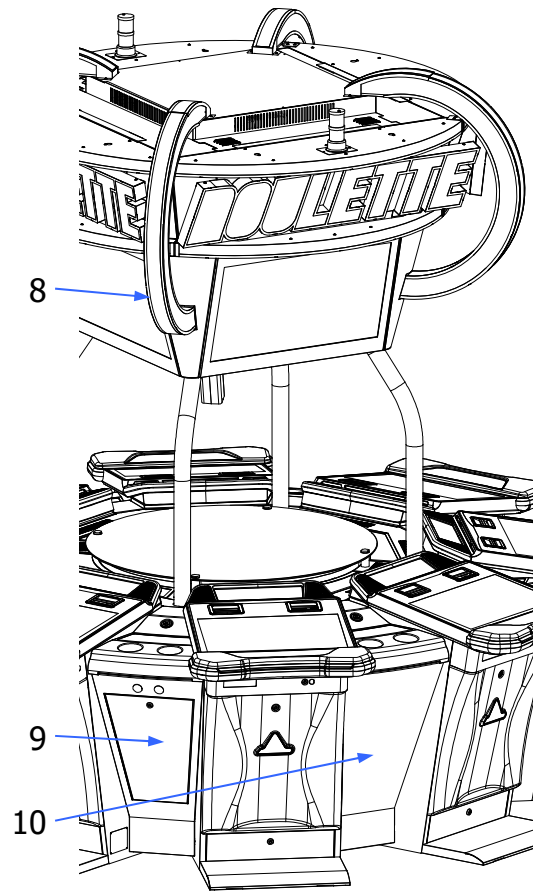

(Drain Spacer side)

1. Tower Light(Optional)
2. Top Sign Unit
3. LCD Unit
4. Center Unit
5. Station
6. RESET/AUDIT Keyswitch
7. Control Spacer Door

8. Ring Unit
9. Drain Spacer Door
10. Spacer Unit

1. 3: Inside View of Center Unit

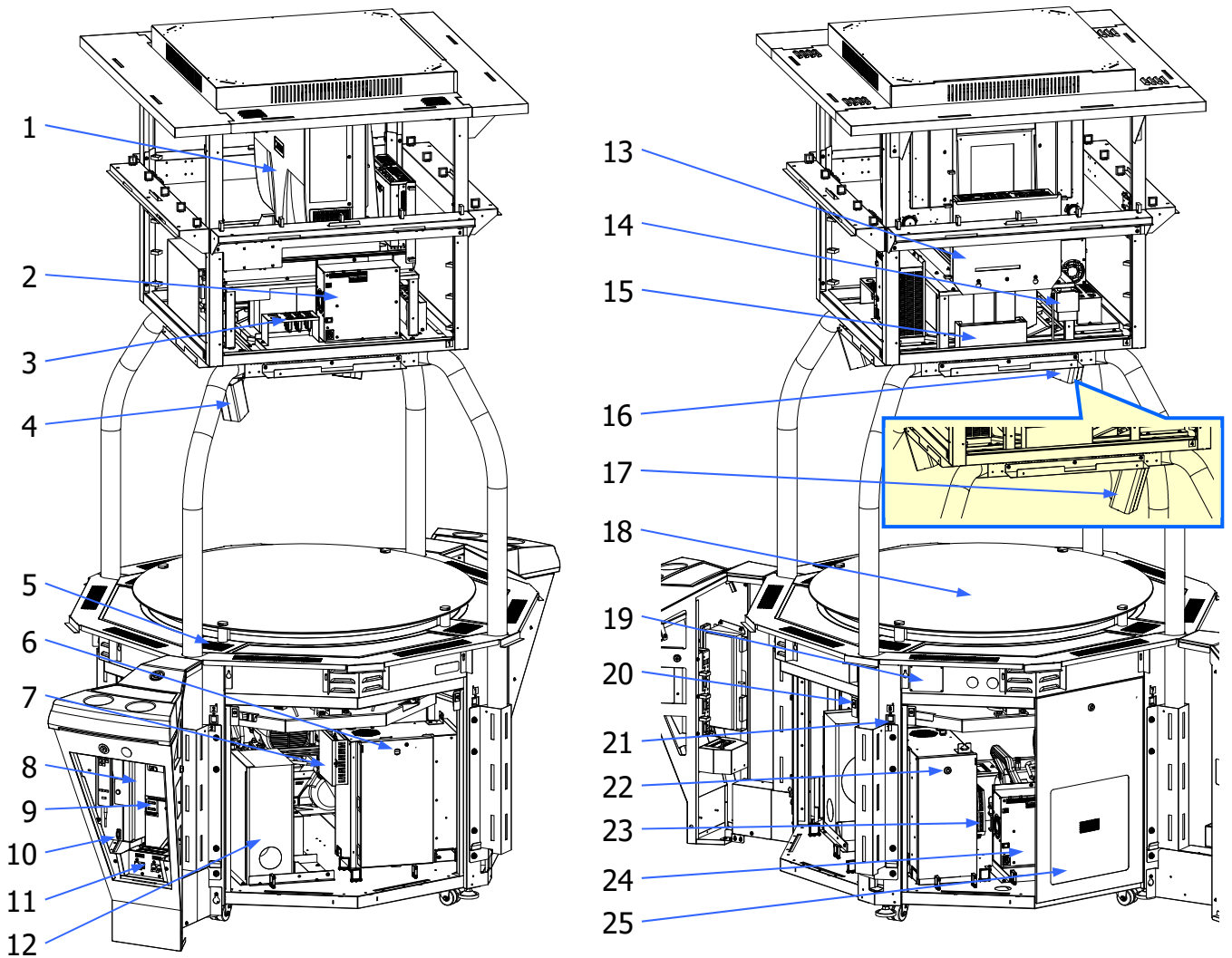

(Control Spacer side View)

- | | |
|--|---|
| 1. Projector | 13. Tracking Camera PC Unit |
| 2. Power Box A | 14. TINKER Unit(for HBVCAM-F2028HD-V11) |
| 3. Breakers | 15. DVI Splitter |
| 4. Tracking Camera | 16. Live Camera (HBVCAM-F2028HD-V11) |
| 5. Speakers | 17. Live Camera (HD-NDI-200) |
| 6. IO Case Unit | 18. Wheel Unit |
| 7. AMP Case | 19. Serial Plate |
| 8. Keyboard / Remote Commander | 20. Center Door Switches |
| 9. PC Changer | 21. LAN Ports |
| 10. GAT3(D SUB) Connector(Optional) | 22. Security Cage Door Lock |
| 11. Power Switch(MAIN SW 1, MAIN SW 2) | 23. Switching Hub |
| 12. Woofer Speaker | 24. Main Power Unit |
| | 25. Center Unit Doors |

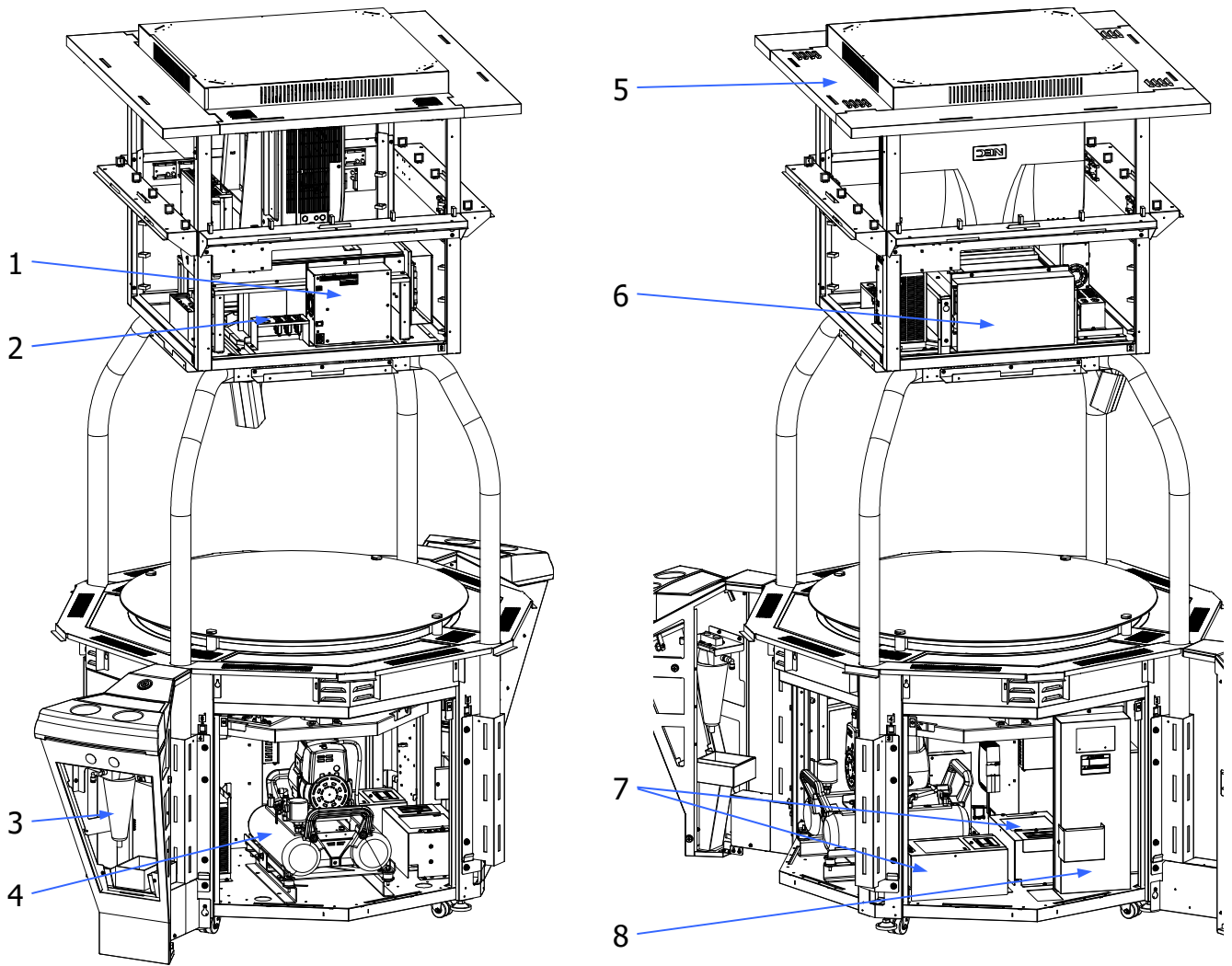

(Drain Spacer side view)

- | | |
|--------------------------|----------------------|
| 1. Power Box B | 5. Top Base Unit |
| 2. Breakers | 6. Top PCB Box |
| 3. Separator Filter Unit | 7. Transformer Box |
| 4. Air Compressor Unit | 8. Switch Board Unit |

1. 4: Outside View of Station

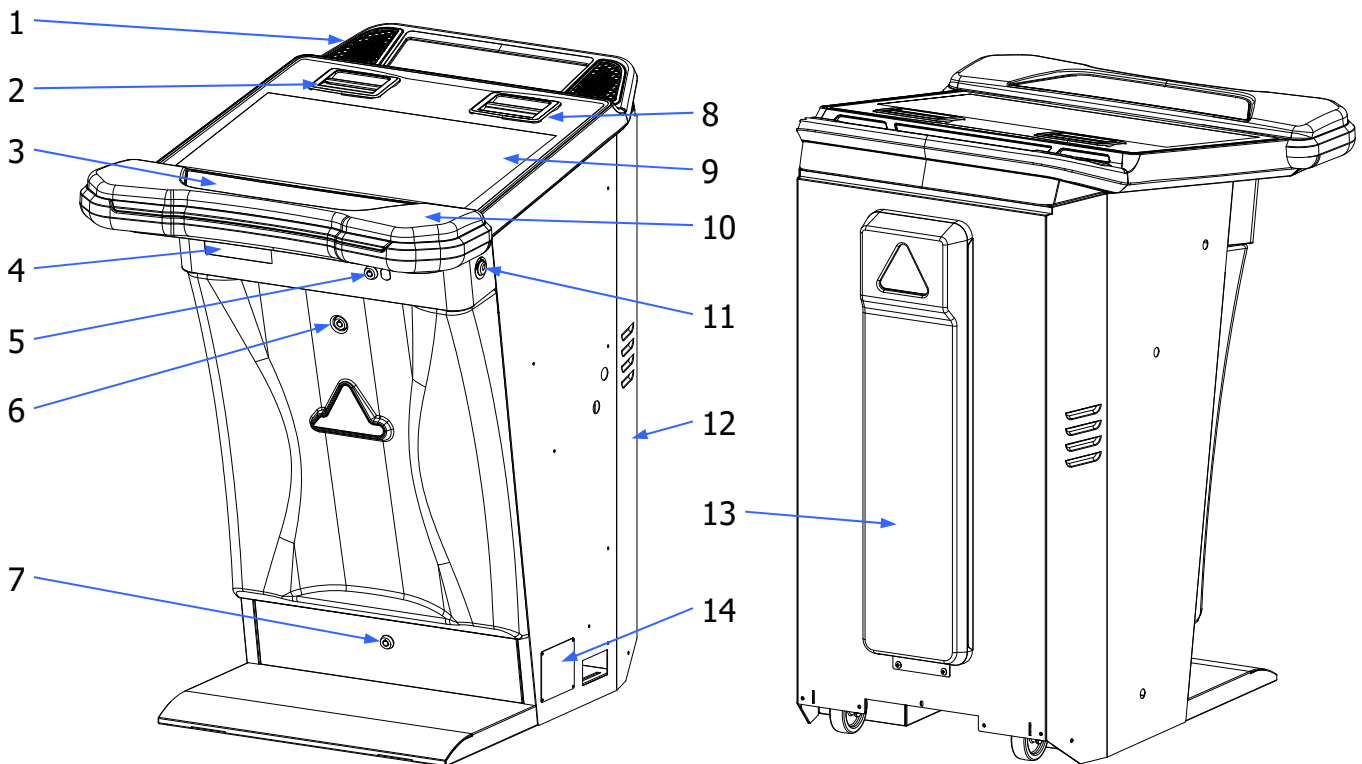

1. Speakers
2. Printer Chute
3. Control Panel
4. Mechanical Meters(Counter)
:Used only in the regions that use the mechanical meters.
5. Top Door Lock
6. Front Door Lock
7. Bottom Door Lock

8. BILL Chute
9. Top Door
10. Arm Rest(Pad)
11. RESET/AUDIT Key Switch
12. Cabinet
13. Back LED(Optional)
14. Serial Plate

1. 5: Inside View of Station

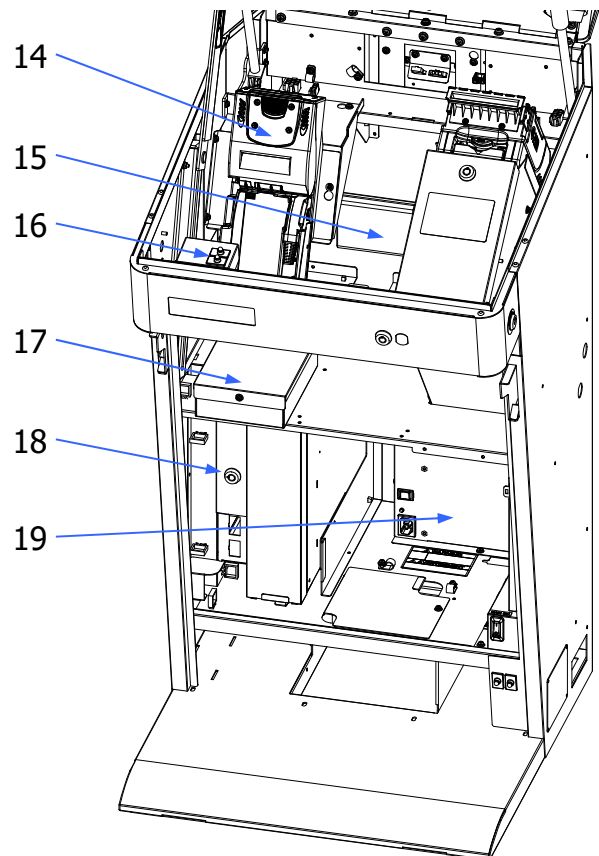
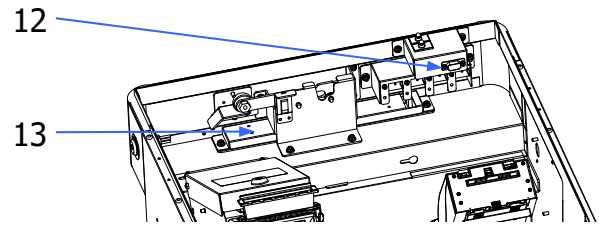
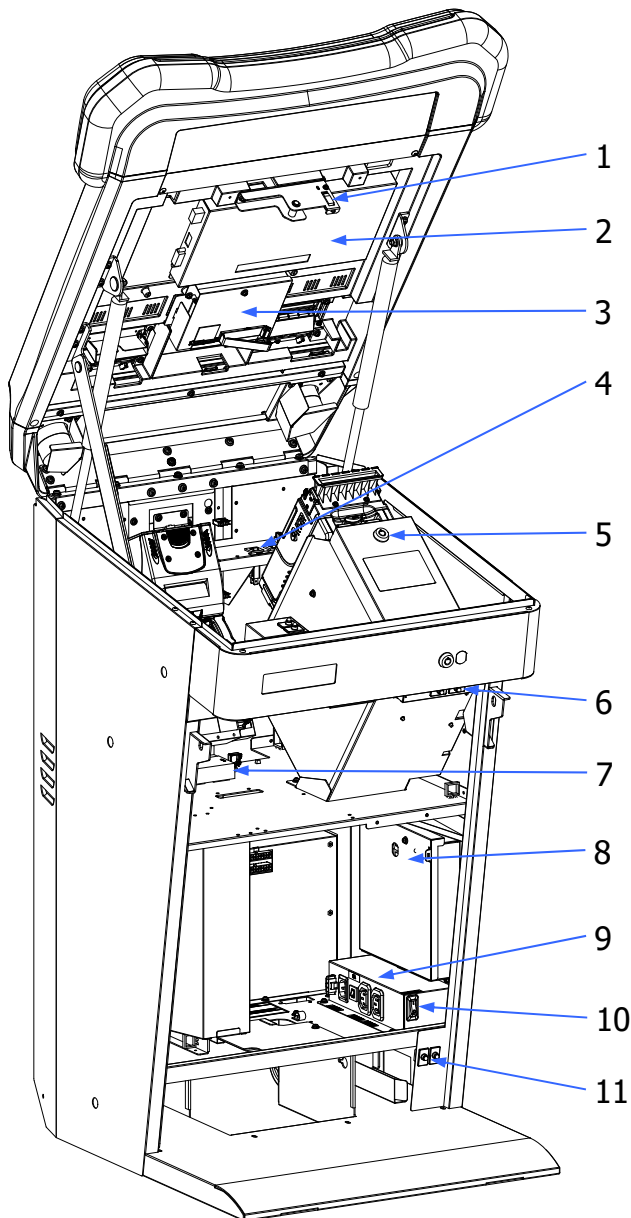

- | | |
|---------------------------------|------------------------------------|
| 1. Top Door Sensor | 12. GAT3(D SUB) Connector(Option) |
| 2. LCD Monitor | 13. Front LED |
| 3. Touch Screen PCB | 14. Ticket Printer |
| 4. Breakers | 15. Audio Module PCB |
| 5. BILL Case(BV CASE) Door Lock | 16. Top Door Switch |
| 6. Front Door Switch and Sensor | 17. SUB IO Case(Option) |
| 7. DDC/EDID Emulator | 18. Security Cage Front Cover Lock |
| 8. IO Case | 19. Power Supply |
| 9. Plug-in Unit(AC Base) | |
| 10. Power Switch | |
| 11. Bottom Door Switch | |

Chapter 2

Unpacking and Inspection

2. 1: Unpacking and Inspection

Unpack the machine, and check for shipping damage. If anything is missing or damaged, immediately contact your local office or distributor.

Supplied Part	QTY
Key (B2155)	1
Key (B1963)	1
Reset Key	1
Tower Light (Option)	(2)

i NOTE:



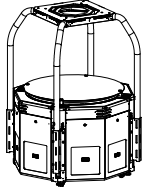
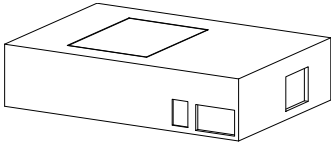
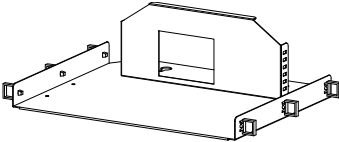
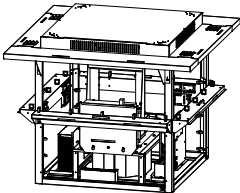
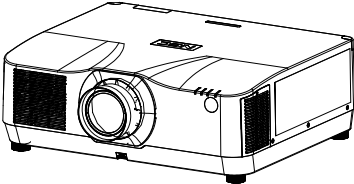
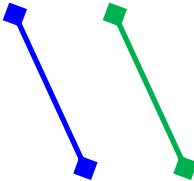
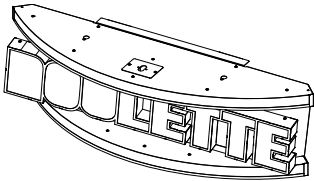
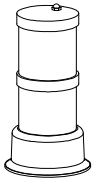

The content of the provided accessories may vary according to specifications.

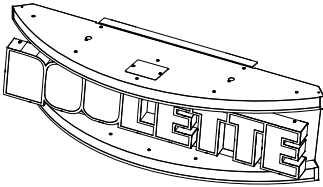
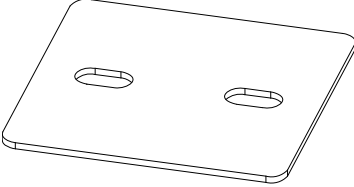
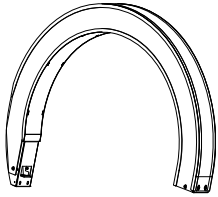
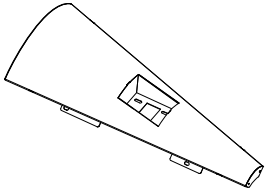
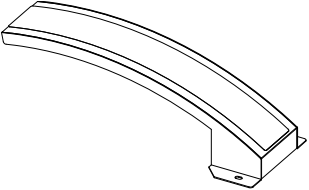
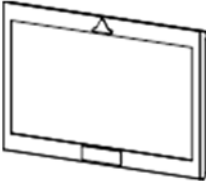
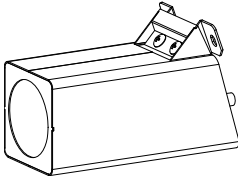
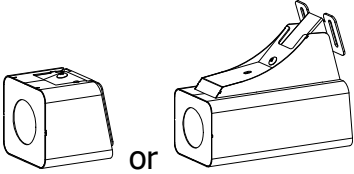
Packing List

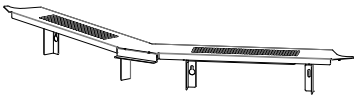
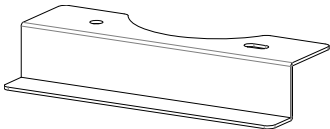
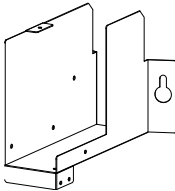
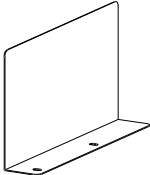
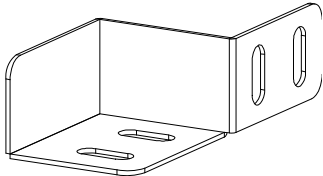
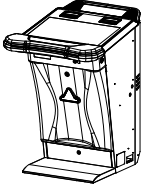
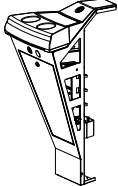
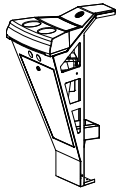

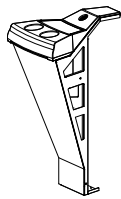

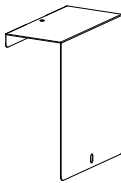
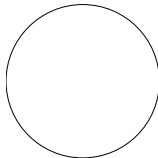





Parts Name		Qty	Appearance
1	Center Unit	1	
2	Tracking Camera PC	1	
3	PC Base	1	
4	Top Base Unit	1	
5	Projector	1	
6	Accessory Cables of Projector · DP · AC(for Projector)	1 for each	
7	Sign A Unit (for Tower Light)	2	
8	Tower Light	2	





Parts Name		Qty	Appearance
9	Sign B Unit	2	
10	Joint Plate	4	
11	Ring	4	
12	Ring Spacer	4	
13	Ring Cover	4	
14	Monitor Assembly • Monitor Unit (32 inch LCD Monitor) • LCD Joint BRKT • Bezel	4	
15	Tracking Camera Unit	1	
16	Live Camera Unit (HBVCAM-F2028HD-V11) or (HD-NDI-200)	1	



Parts Name		Qty	Appearance
17	Joint BRKT A Unit	4	
18	Joint BRKT B	4	
19	Harness BRKT A	2	
20	Separate BRKT A	2	
21	Joint BRKT C	2	
22	Station	8	
23	Control Spacer Unit [RIGHT FILLER OF STATION No.03] (for Power Switch)	1	
24	Drain Spacer Unit [RIGHT FILLER OF STATION No.07] (For Air Filter)	1	

Parts Name		Qty	Appearance
25	Spacer Units (RIGHT FILLER OF STATION No.01, 02, 04, 05, 06 and 08)	6	
26	LAN Cable(for Station: 2.5m)	8	
27	Harness Cover	2	
28	Ball (for Roulette)	5	
29	AC Cable(for Station)	8	

Fastener List

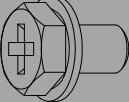
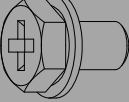
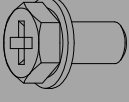
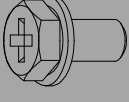
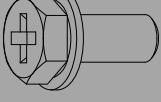
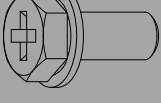
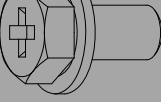
Fasteners		Appearance
Ab	TRUSS M4x8 BLK	
Bb	TRUSS M4x10 BLK	
Cb	TRUSS M4x12 BLK	
Db	TRUSS M5x10 BLK	
Eb	TRUSS M5x12 BLK	
F	PAN M4X8 3P	
Fb	PAN M4X8 3P BLK	
G	PAN M4x10 3P	
Gb	PAN M4x10 3P BLK	
H	PAN M4X12 3P	
Hb	PAN M4X12 3P BLK	

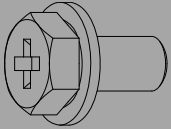
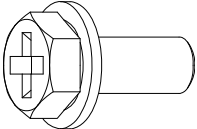
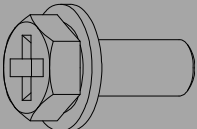
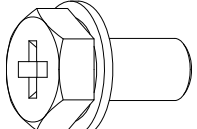
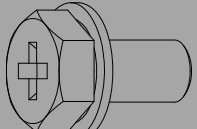
Fasteners		Appearance
I	PAN M5x10 3P	
Ib	PAN M5x10 3P BLK	
J	PAN M5x12 3P	
Jb	PAN M5x12 3P BLK	
K	HEX UPSET M6 x 10 3P	
Kb	HEX UPSET M6 x 10 3P BLK	
L	HEX UPSET M6 x 12 3P	
Lb	HEX UPSET M6 x 12 3P BLK	
M	HEX UPSET M6 x 16 3P	
Mb	HEX UPSET M6 x 16 3P BLK	
N	HEX UPSET M8 x 16 3P	

Fasteners		Appearance
Nb	HEX UPSET M8 x 16 3P BLK	
O	HEX UPSET M8 x 20 3P	
Ob	HEX UPSET M8 x 20 3P BLK	
P	HEX UPSET M10 x 20 3P	
Q	HEX UPSET M10 x 20 3P BLK	
R	FLANGE NUT M4	
S	FLANGE NUT M5	

Chapter 3

Installation

3. 1: Cabinet Dimensions

The Whole Machine dimensions are depicted below.

Secure enough space so that the doors can be easily opened for POWER-ON/OFF, maintenance, and so on.

- **Outer Dimension - Unit: mm** (excluding all parts sticking out)

The TOWER LIGHT is optional.

Layout 8 Stations

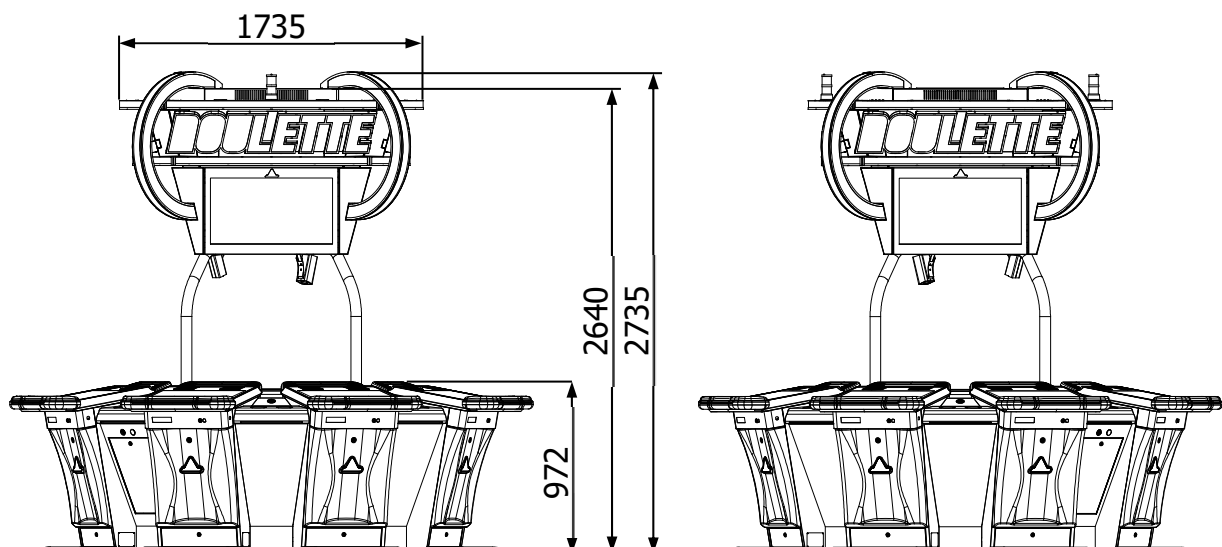
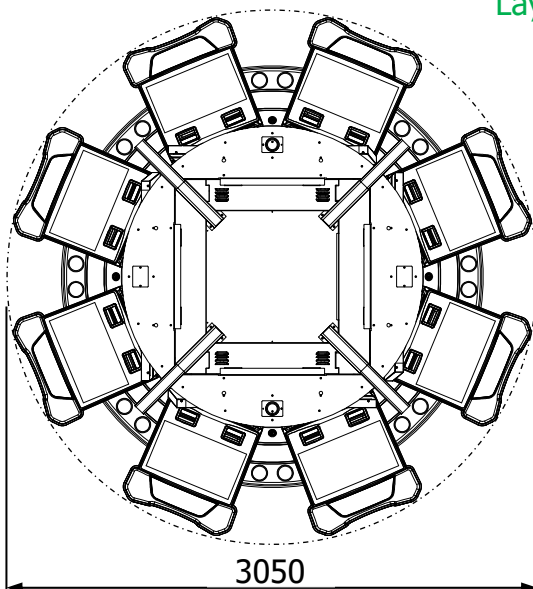

3. 2: Installing the Machine

⚠ WARNING!

- Installation must be performed by qualified service personnel.
- To install this machine, at least 4 people are necessary.
- Before starting installation procedures, refer to "**Safety Instructions**".
- Interblock d.o.o. cannot be held liable for damages or injuries caused by improper installation.

i NOTE:

It is possible to install to this machine a maximum of 50 stations, including the 8 stations incorporated by the Center Unit. For more details.

Maximum number of stations can be 50 pcs

Center Unit Stations 8 pcs

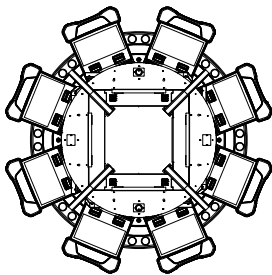

+

Extension Stations 42 pcs

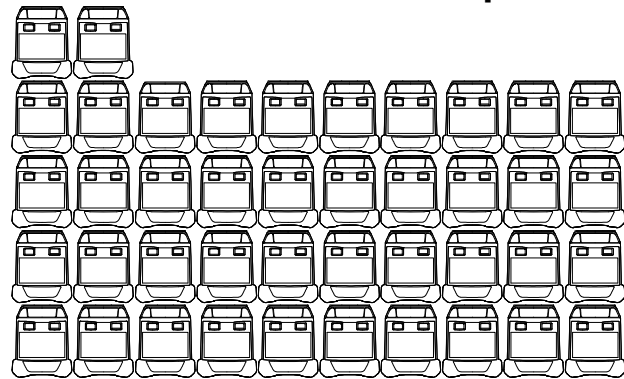

[Limitation for extension]

- Extension Stations are connected by using the LAN Cable that is included inside the HUB.
- According to the number of Extension Stations and their distance, connect the Station to a 2nd HUB in relay to the Center Unit HUB.
- It is possible to connect up to 15 stations to each 2nd HUB.
- It is not possible to connect the 2nd HUB to a 3rd HUB. Add multiple 2nd HUBs to the Center Unit, and diverge to each station.

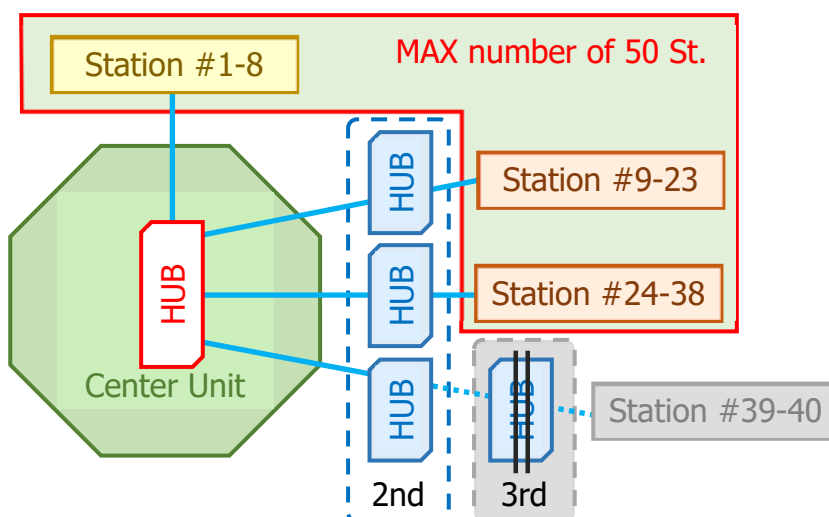

Preparation

- To preserve the horizontal level, install the machine on a solid surface that will not suffer the influence of vibration.
- The installation requires operations on high places. Check the procedures in advance and arrange a disposition that will allow enough space for the work.
- Mount the machine in an area equipped with power and communication cables.
- This machine needs power outlets for the Center Unit, and exclusive power plugs for the Projector, the Tracking Camera PC, each Station and the optional USB Chargers .

i NOTE:

The Projector and the Tracking Camera PC will boot up when connected to an electrified power source. Remember that they are not connected to the Power Switch of the Center Unit.

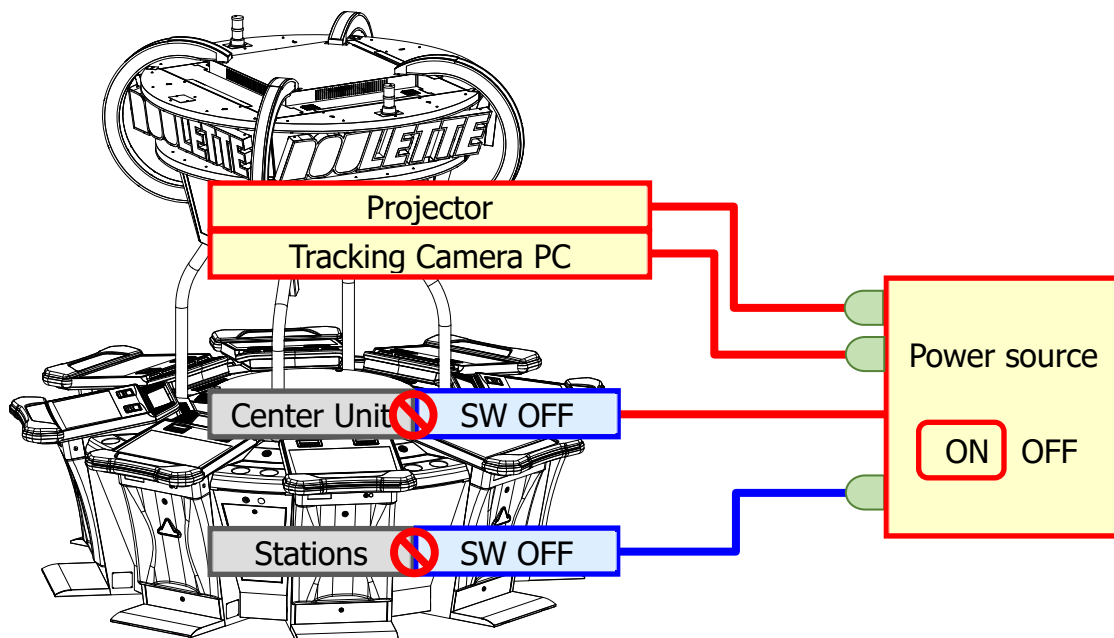

Before installing the machine, prepare the following tools:

- Ratchet wrench with sockets of S=7, 8, 10, 12, 13, and 19mm Otherwise, open-end wrenches (+19mm) with the same sizes
- Phillips screwdriver (#2)
- HEXALOBULAR INTERNAL(Torx) screwdriver
- Hexagon wrench
- Step ladder
- Waste cloth

3. 2. 1: Center Unit

3. 2. 1. 1: Installing the Center Unit

1. Prepare the following Parts.

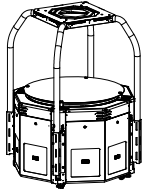
Parts Name	Qty	Appearance
Center Unit	1	

2. Remove all the shipping materials from the Center Unit. Check the exterior to verify that there are no damages etc.
3. According to the chosen layout, place the Center Unit at your desired position on a flat floor where cables for electricity and communication have already been installed.

i NOTE:

When planning the layout of the Center Unit, remember that its Power Cable is connected to the Terminal Block through a hole on the bottom of the Center Unit.

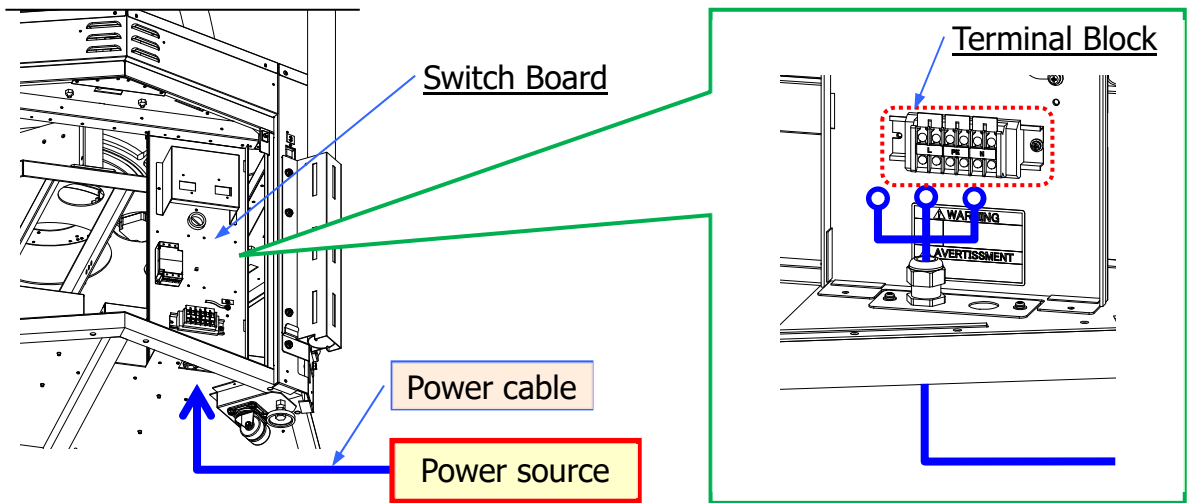

4. Secure the Center Unit to the floor by lowering the adjuster situated at the bottom of the machine.

! WARNING!

Secure the Center Unit so that it will not move during installation process.



3. 2. 1. 2: Assembling the Tracking Camera PC Unit

1. Prepare the following Parts.

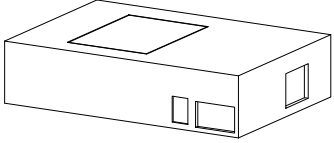
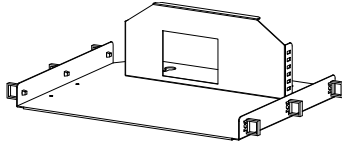
Parts Name	Qty	Appearance
Tracking Camera PC	1	
PC Base	1	

2. It is possible to install on the Tracking Camera PC the supplied BRKTs by using the screws included in the package. (Please refer to the Tracking Camera PC manual.)

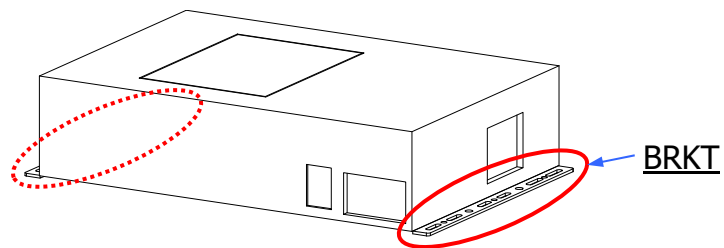

3. Affix the Tracking Camera PC to the PC Base by using 4 screws.

Fasteners		Qty	Appearance
F	PAN M4x8 3P	4	

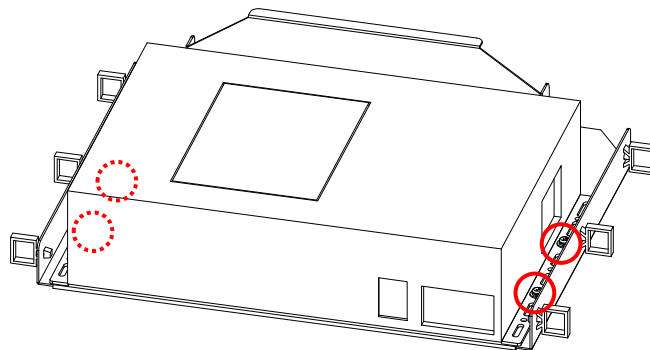

4. Refer to the illustration below and connect the Connectors of the PC Base to the Tracking Camera PC.

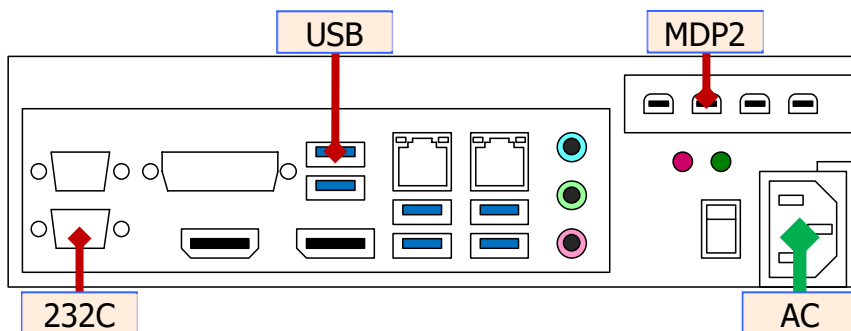

3. 2. 1. 3: Assembling the Top Base Unit

1. Prepare the following Parts.

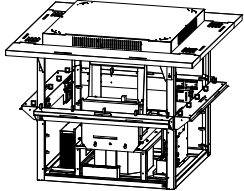
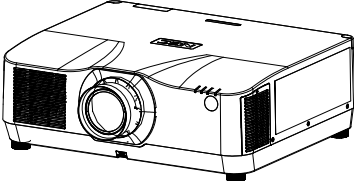
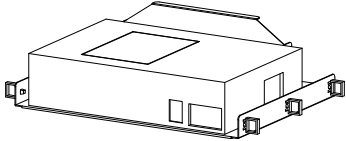
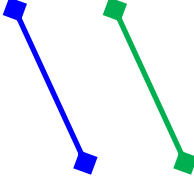
Parts Name	Qty	Appearance
Top Base Unit	1	
Projector	1	
Tracking Camera PC Unit (Assembled in 3.2.1.2)	1	
Accessory Cables of Projector · DP · AC(for Projector)	1 for each	

- Detach the Top Base Cover by removing the 4 screws.

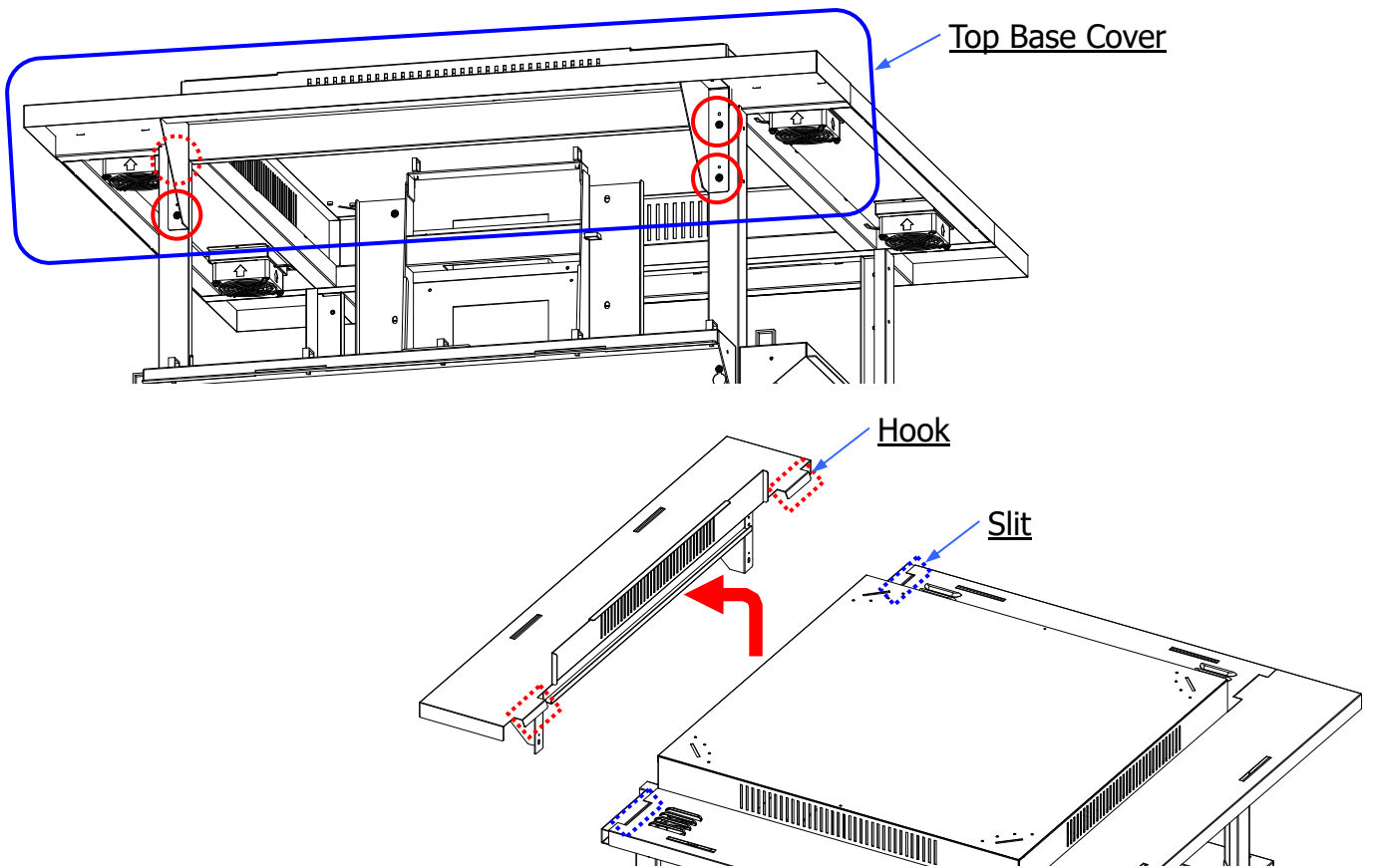

- Remove the connectors by referring to the image below.

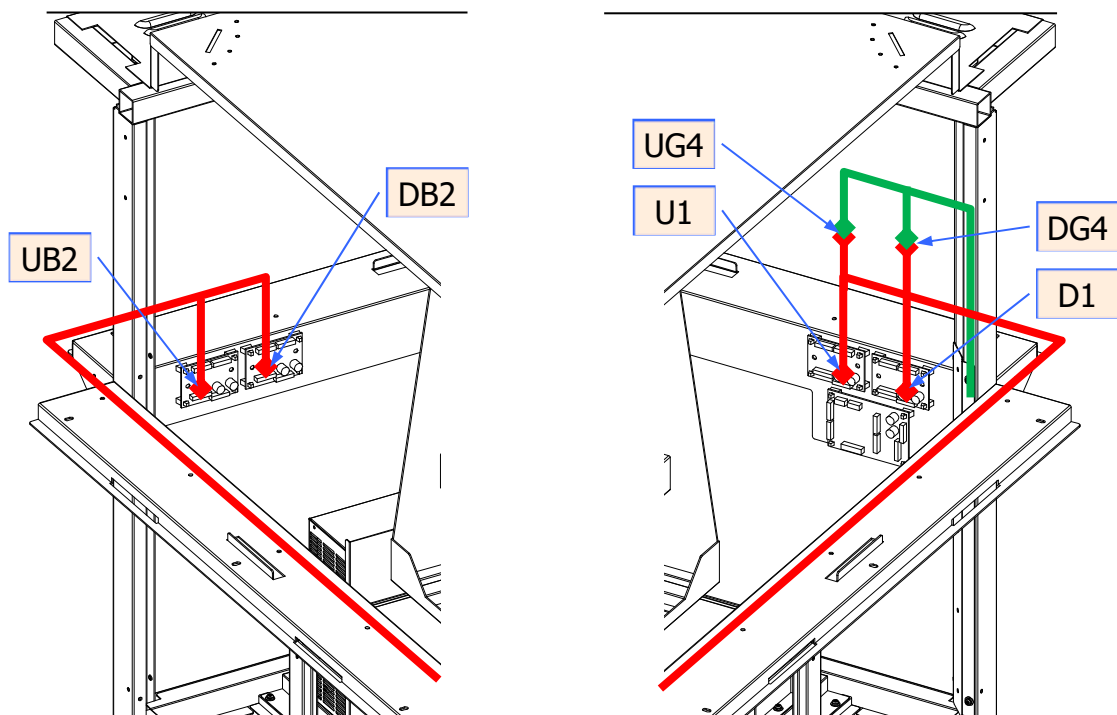

4. Detach the Top Frame by removing the 4 screws.

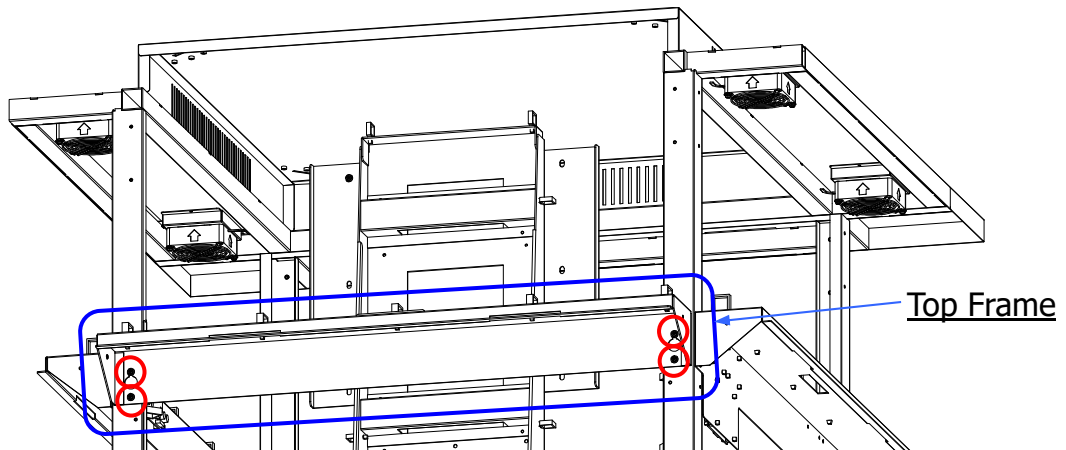

5. Pull the Slide Base out by removing the 3 screws.

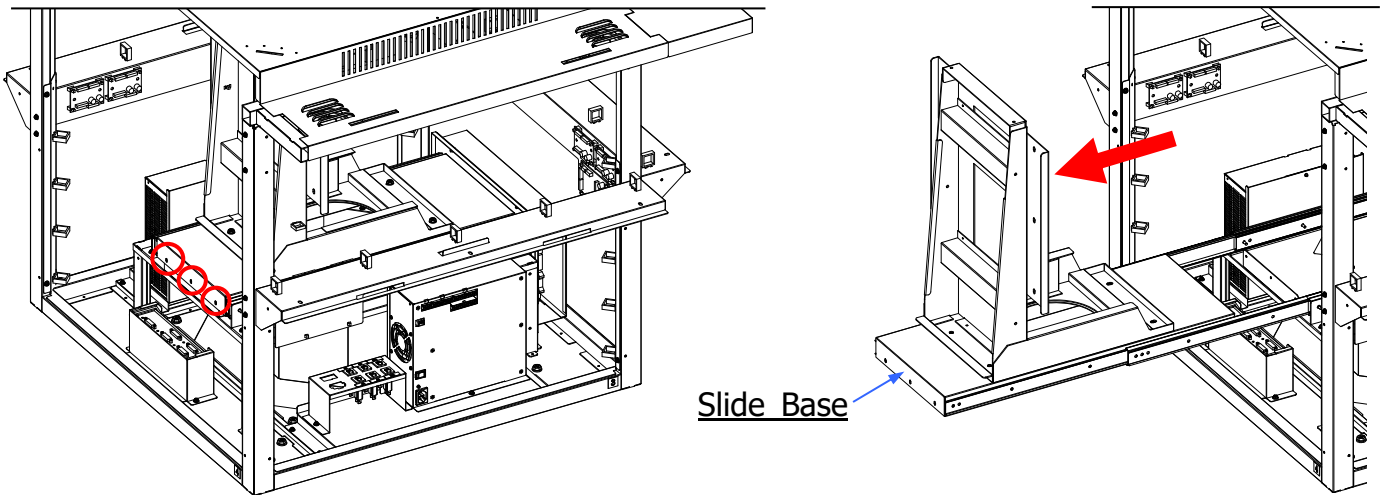

6. Detach the Projector Base NEC by removing the 4 screws.

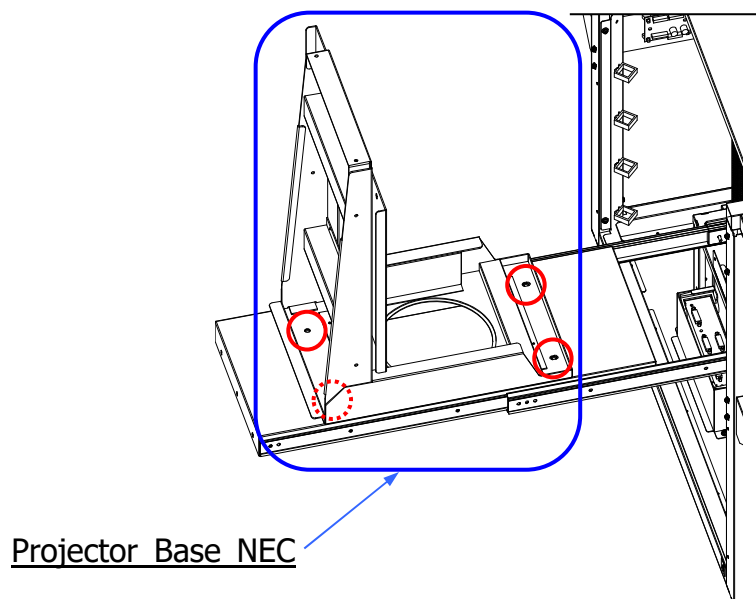

7. Lay the Projector pointing its Installing face upwards.

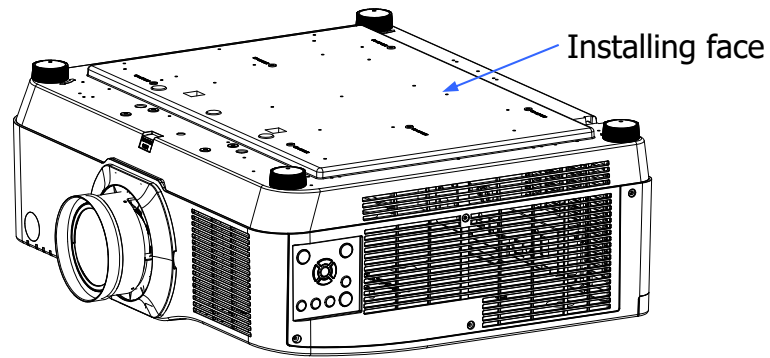

8. Put the Projector Base NEC onto the Projector and affix the Projector by using the 6 screws.

Fasteners		Qty	Appearance
F	PAN M4x8 3P	6	

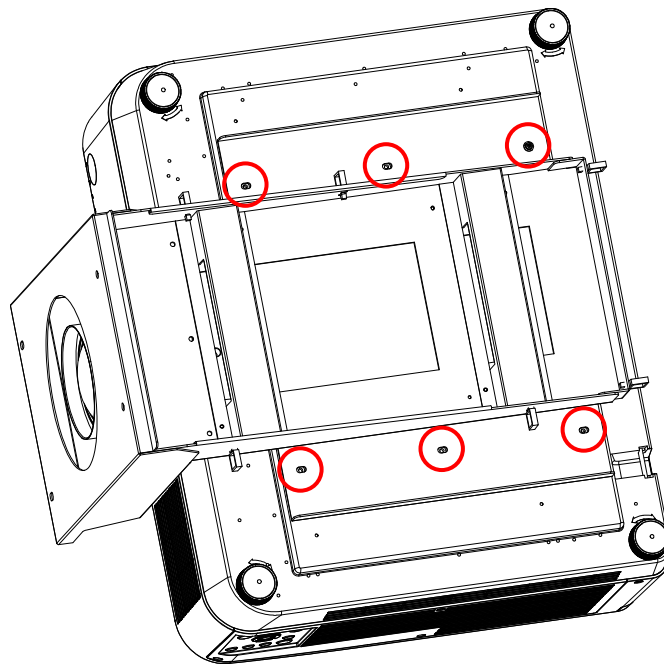

9. Connect the [DP] and [AC](for Projector) Cables and make sure that they are securely seated, then fix them by using the clamps as illustrated.

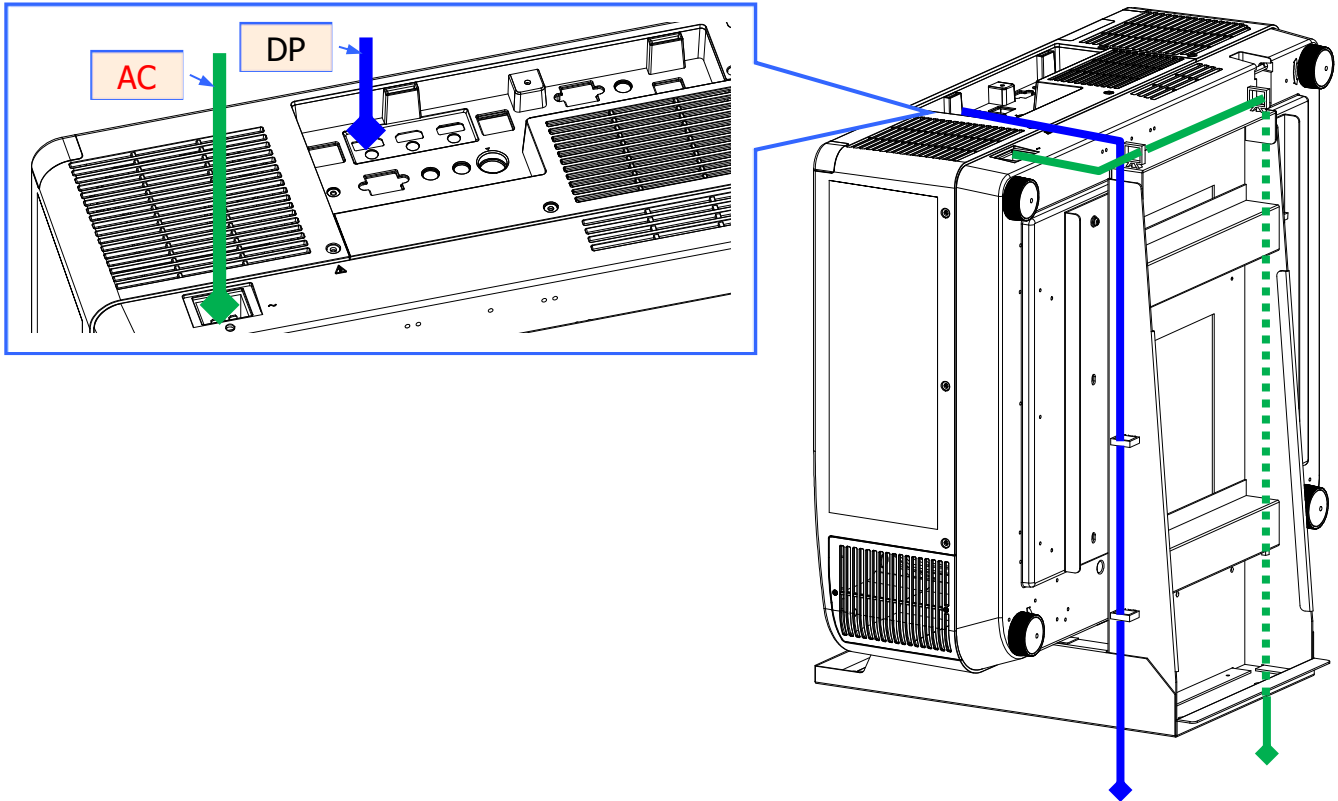

10. Return the Projector Base NEC to its original position and affix it by using bolts.

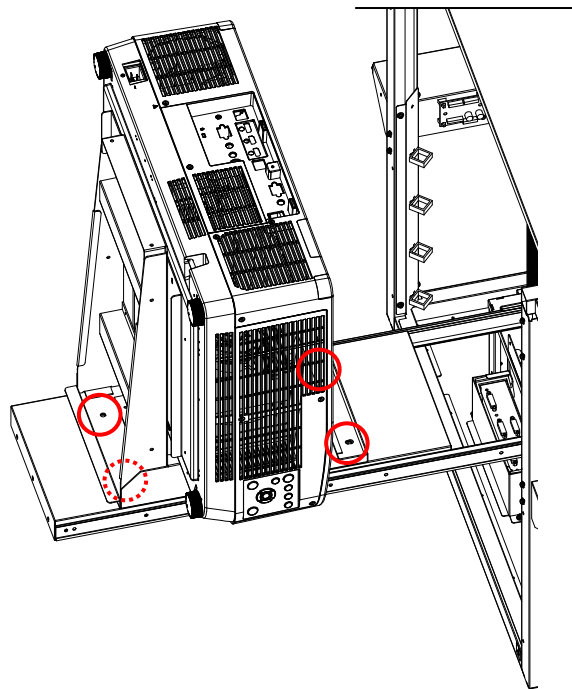

11. Return the Slide Base to its original position. Then put the Camera PC Unit on the front of the Slide Base and affix it by using the screws previously removed.

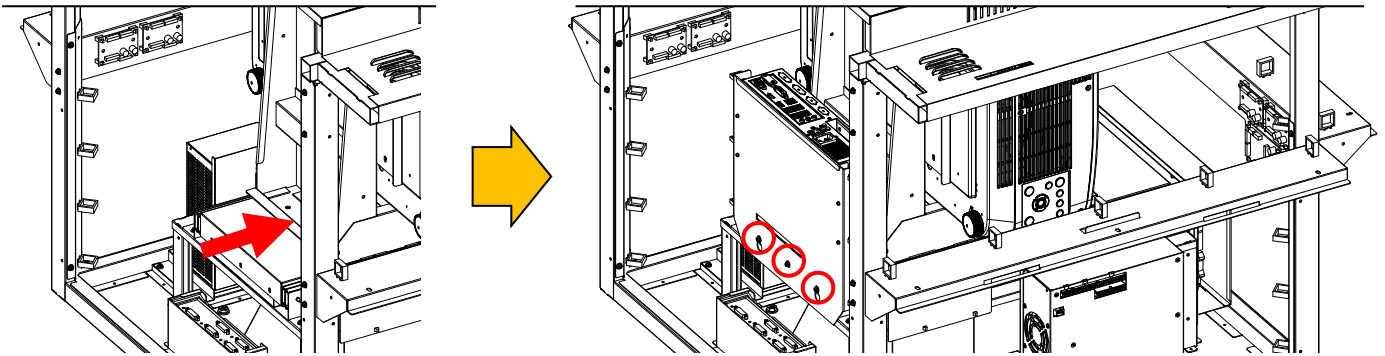

12. Connect the [DP] Cable, connected to the Projector at STEP 9, to the [DP] Connector of the Tracking Camera PC Unit. Then connect the [USB 3.0] Cable that is on the Top Base Unit, to the [USB 3.0] Connector of the Tracking Camera PC Unit that is illustrated below.

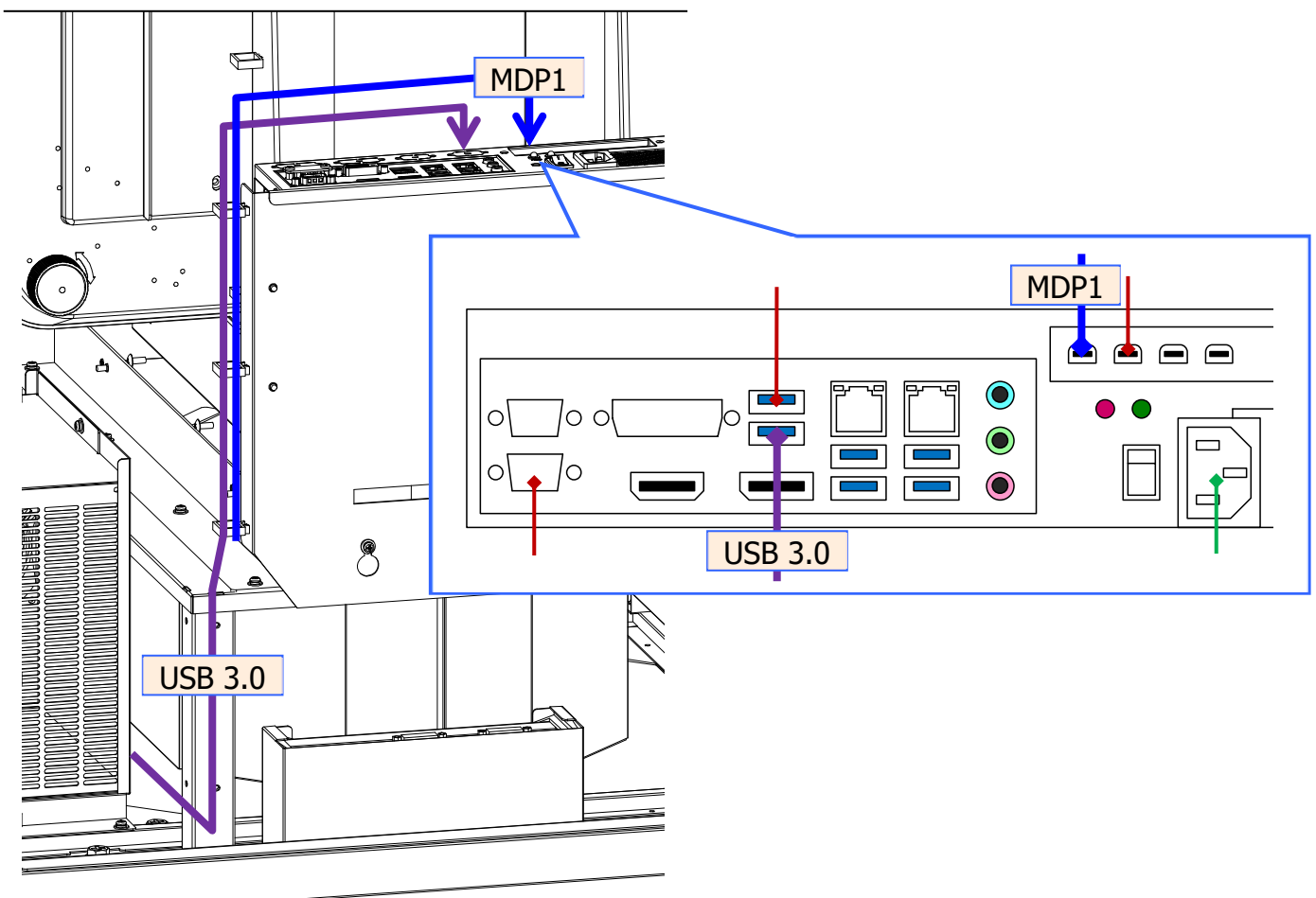

13. Return the Top Frame to its original position and affix it by using screws, and then connect the connectors.

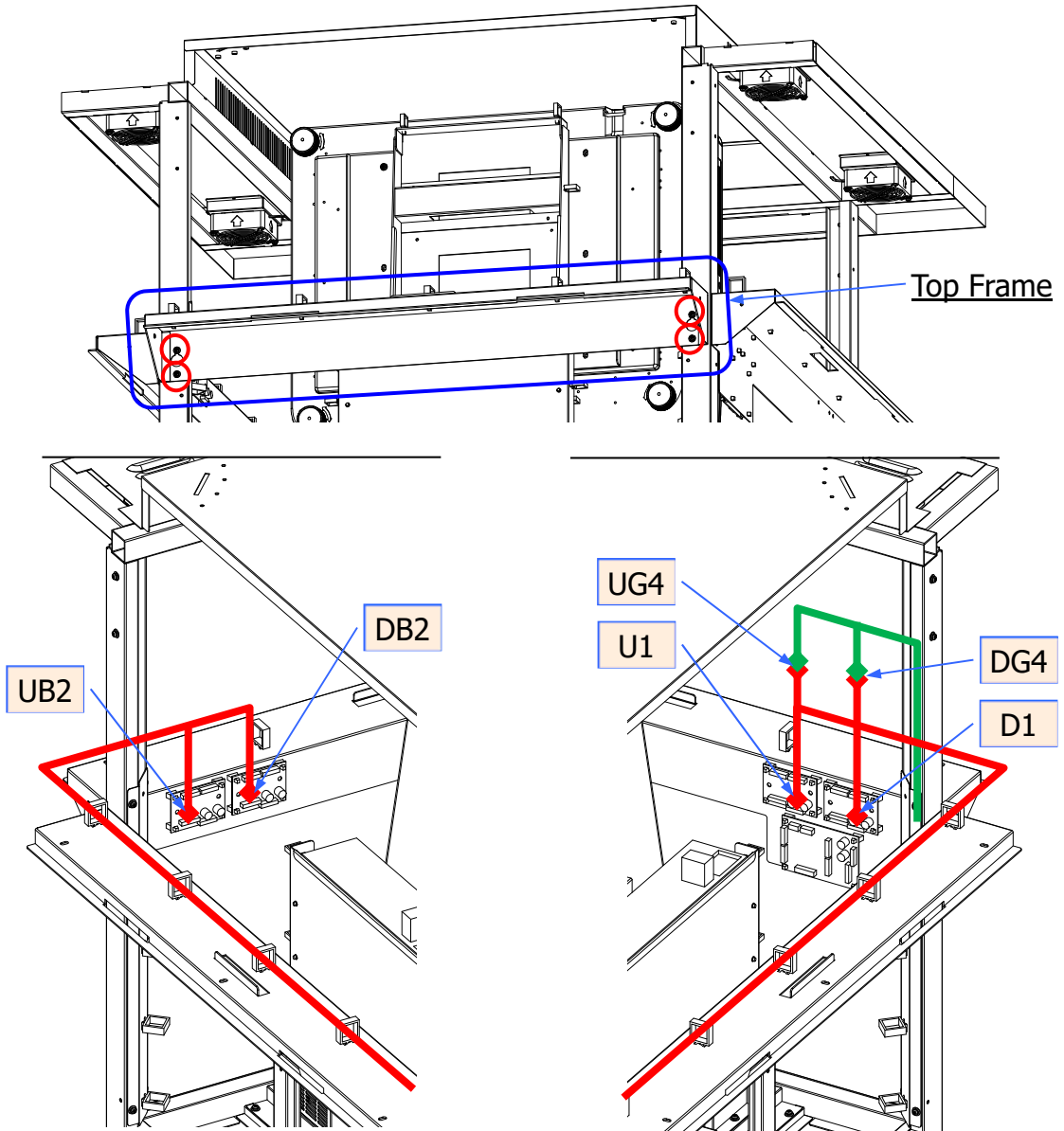

14. Return the Top Base Cover to its original position and affix it by using screws.

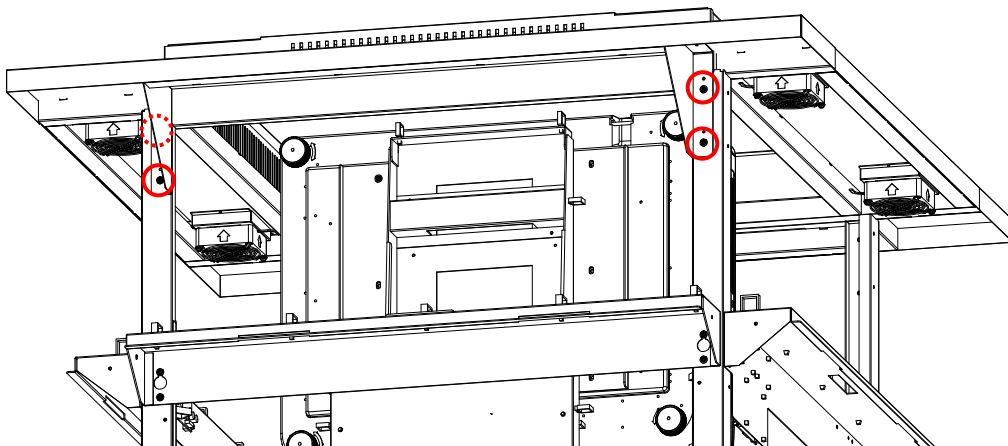

3. 2. 1. 4: Installing the Top Base Unit onto the Center Unit

1. Prepare the following Parts.

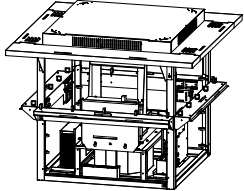
Parts Name	Qty	Appearance
Top Base Unit (Assembled in 3.2.1.3)	1	

CAUTION!

Raise the Top Base Unit holding the frames indicated by the red line. Do not hold the Top Base Cover indicated by the blue line.

Do not hold the Top Base Cover when moving the Top Base Unit.

Top Base Cover

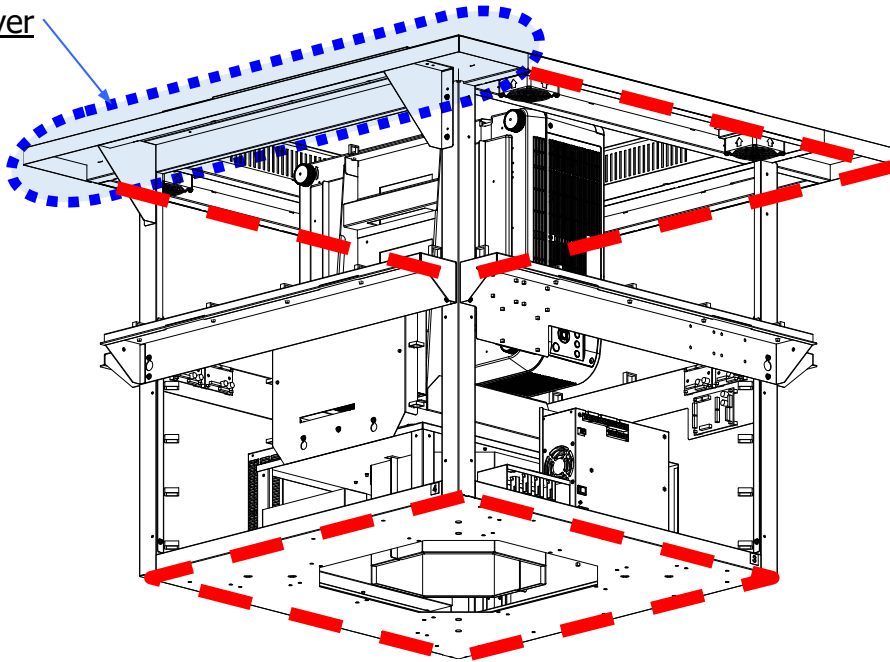

2. Before the procedure, check the cables for the Top Base Unit and the Center Unit, and arrange them so that they will not get in the way during the next procedures.

i NOTE:

Cables are stored in the interstice of the Pole Joint Base Unit. The Top Unit has to be placed over the Pole Joint Base Unit, so pay attention that no cables rise out of the interstice.

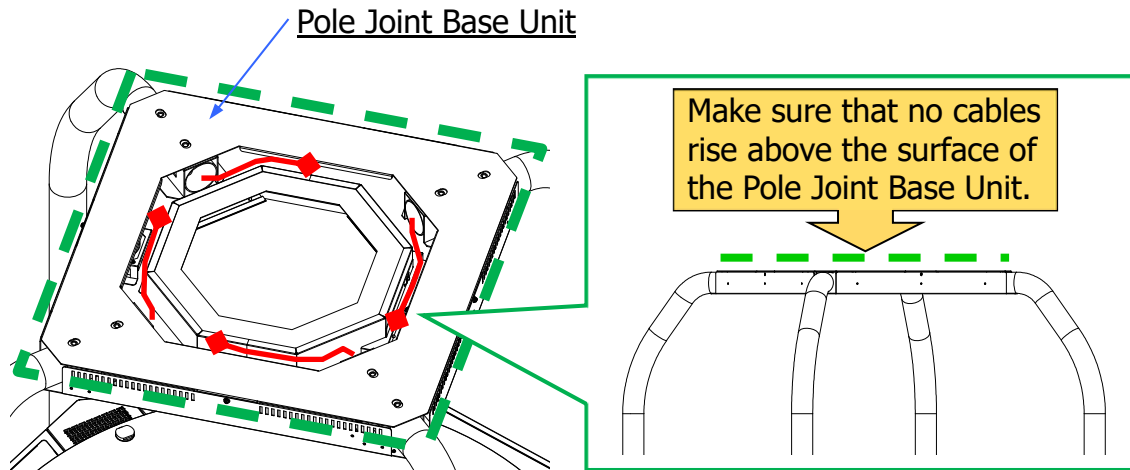

3. Install the Top Base Unit on the top of the Poles of the Center Unit by matching the direction of the Unit, as illustrated below. Pay attention not to pinch the cables.

⚠ WARNING!

- To install this machine, at least 4 people are necessary.
- Once the installing procedure is started, never let go of the Top Base Unit until it is affixed to the Center Unit.
- Since the operation will be performed in a high place, pay enough attention also to the safety of the surrounding area.

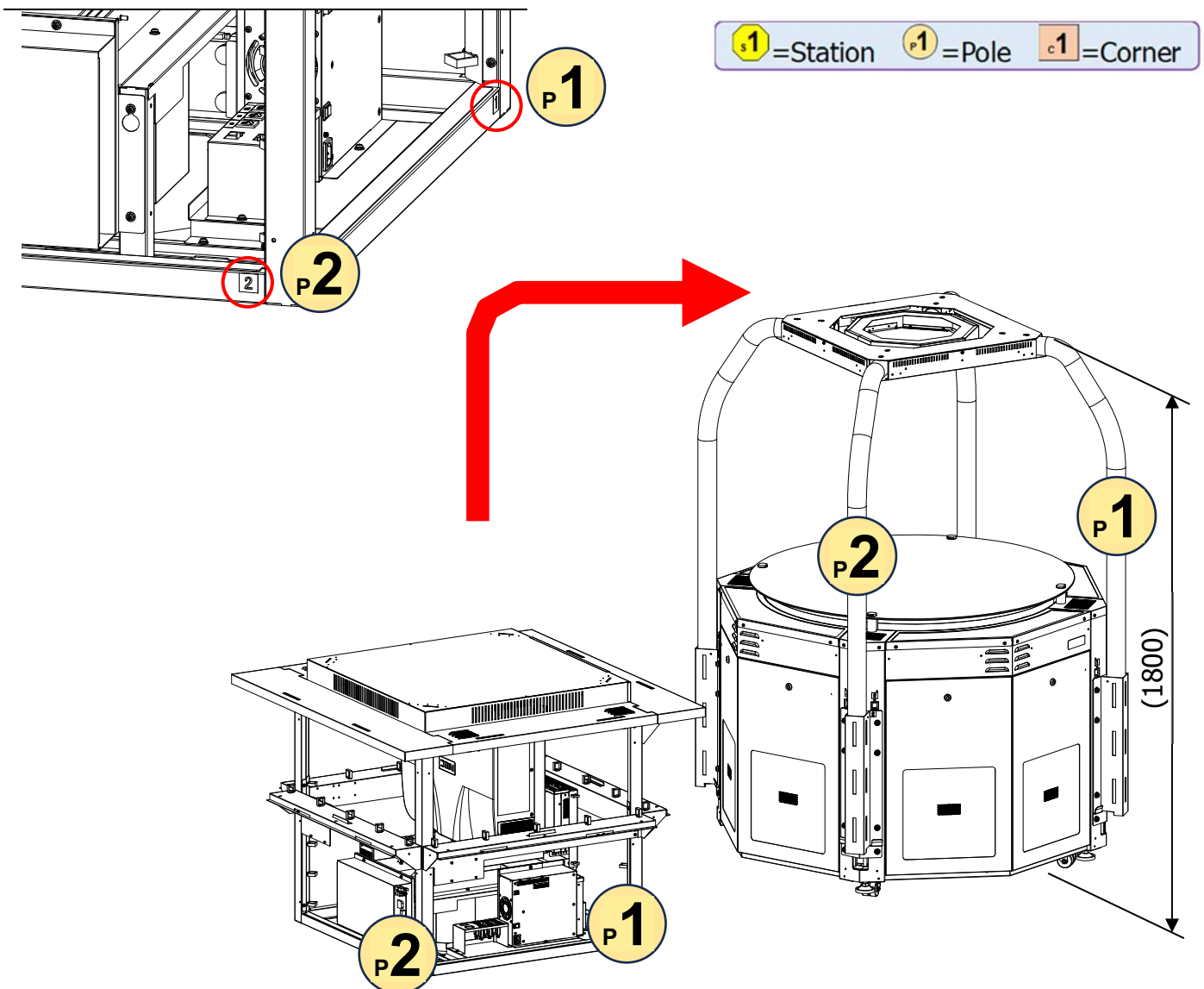

4. Affix the Top Base Unit on the Center Unit by using 8 bolts.

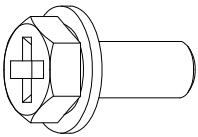
Fasteners		Qty	Appearance
O	HEX UPSET M8 x 20 3P	8	

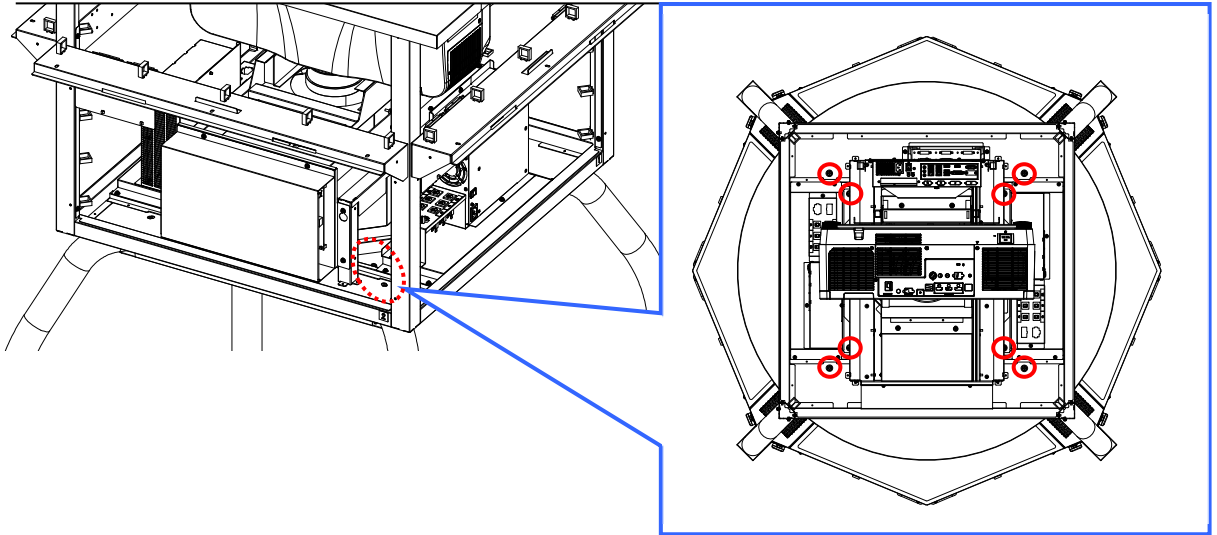

At this point the machine should look like this.

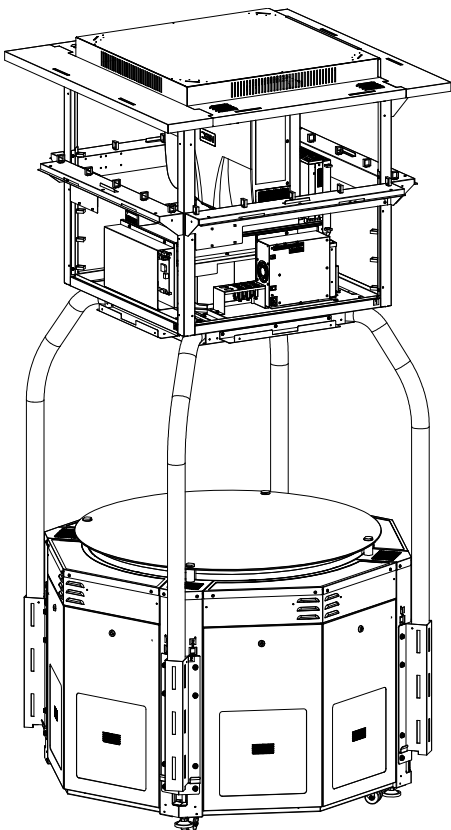

- Connect the [DVIC] Connector of Pole 1 to the [DVIC] Connector of the DVI Splitter, and the [TLR] Connector to the [TLR] Connector of the Top Base Unit.

Pole No.	Connectors from Poles	Connectors of Top Base Unit
1	[DVIC], [TLR]	[DVIC], [TLR]
2		
3		
4		

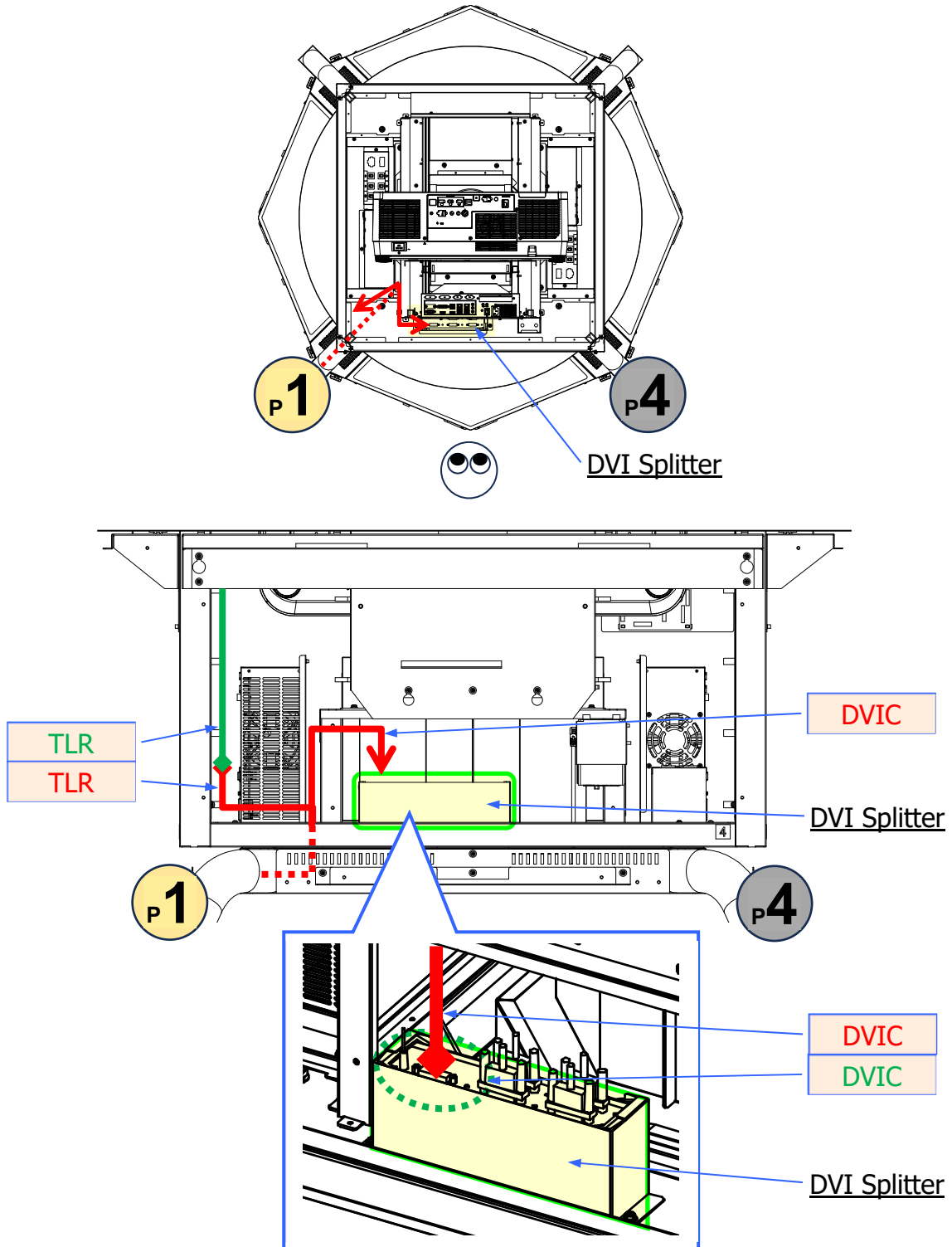

6. Connect the [Pin Plug] of Pole 1 to the [REMOTE] Socket of the Projector.

Pole No.	Connectors from Poles	Connectors of Top Base Unit
1	[Pin Plug]	[REMOTE]
2		
3		
4		

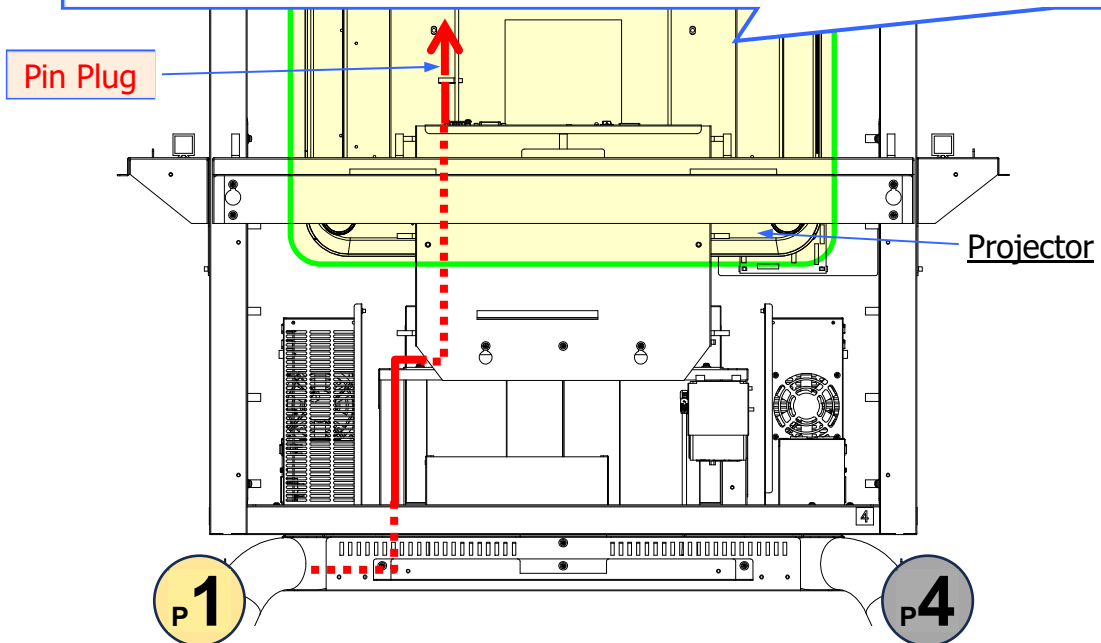
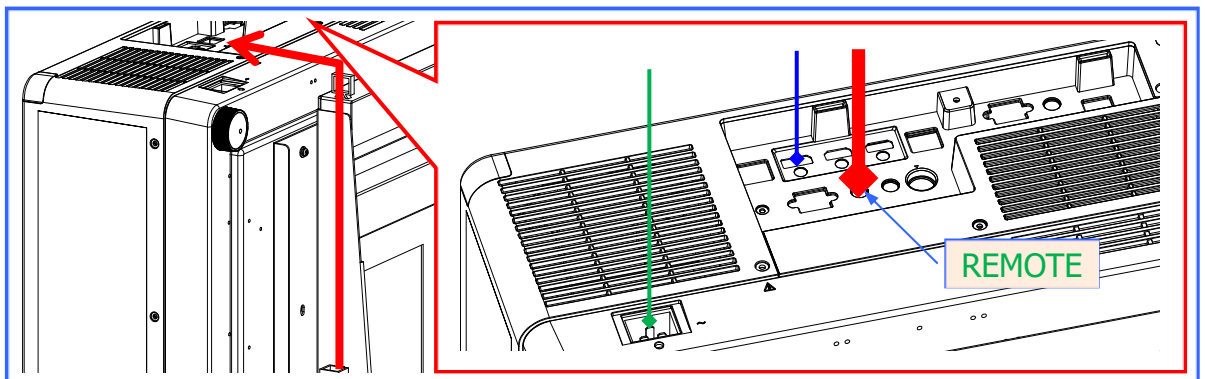
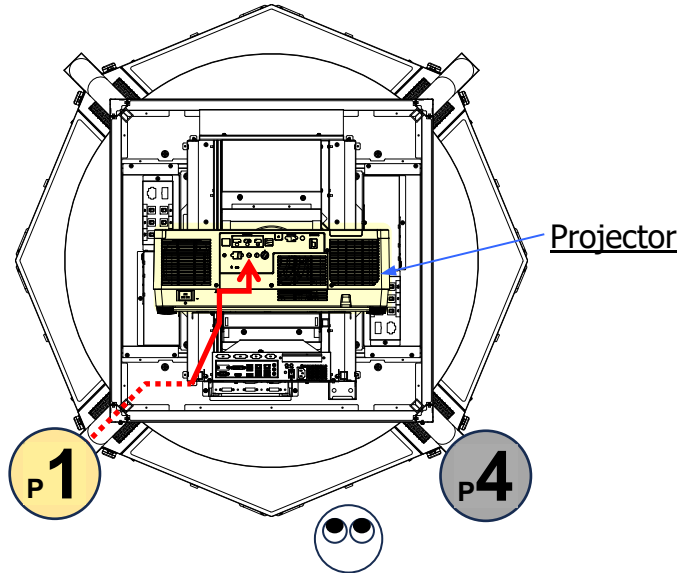

- Connect the [AC(OUT)] Cable of Pole 3 to the [AC(IN)] Cable that was connected to the Projector at 3.2.1.3.

Pole No.	Connectors from Poles	Connectors of Top Base Unit
1		
2		
3	[AC(OUT)]	[AC(IN)] for Projector
4		

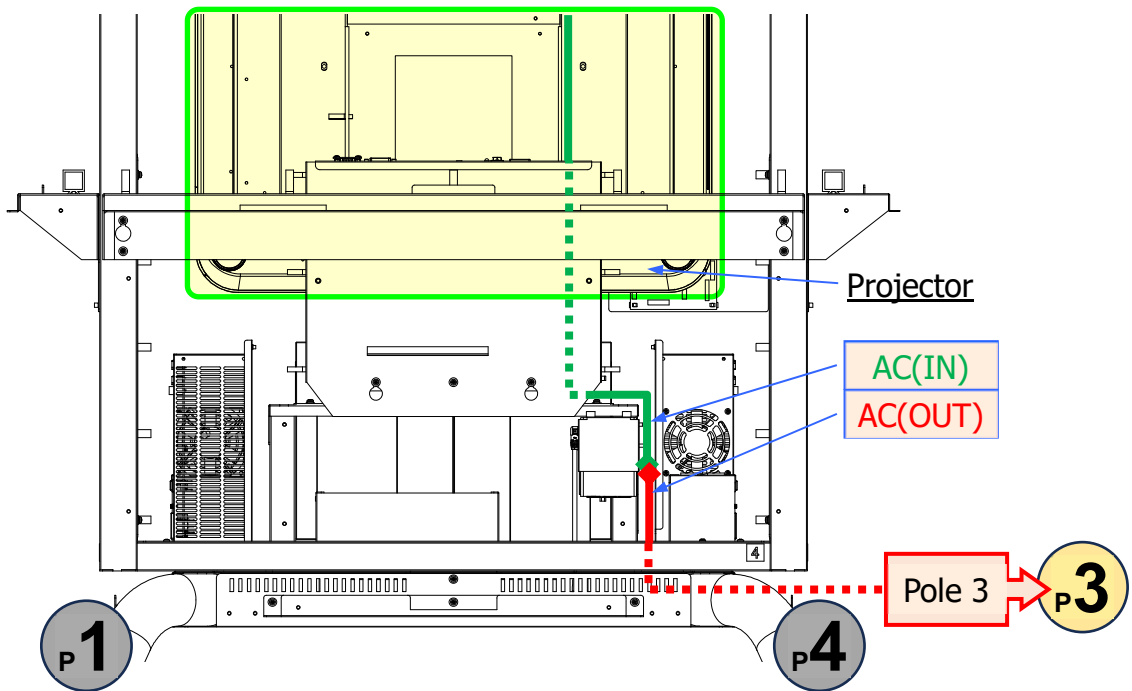
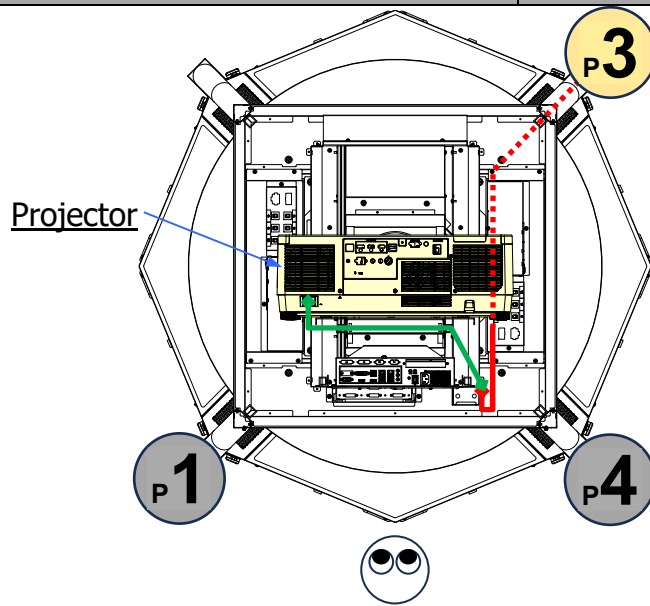

8. Connect the [AC(OUT)] Cable of Pole 3 to the [AC(IN)] Cable that was connected to the Tracking Camera PC at 3.2.1.2.

Pole No.	Connectors from Poles	Connectors of Top Base Unit
1		
2		
3	[AC(OUT)]	[AC(IN)] for Tracking Camera PC
4		

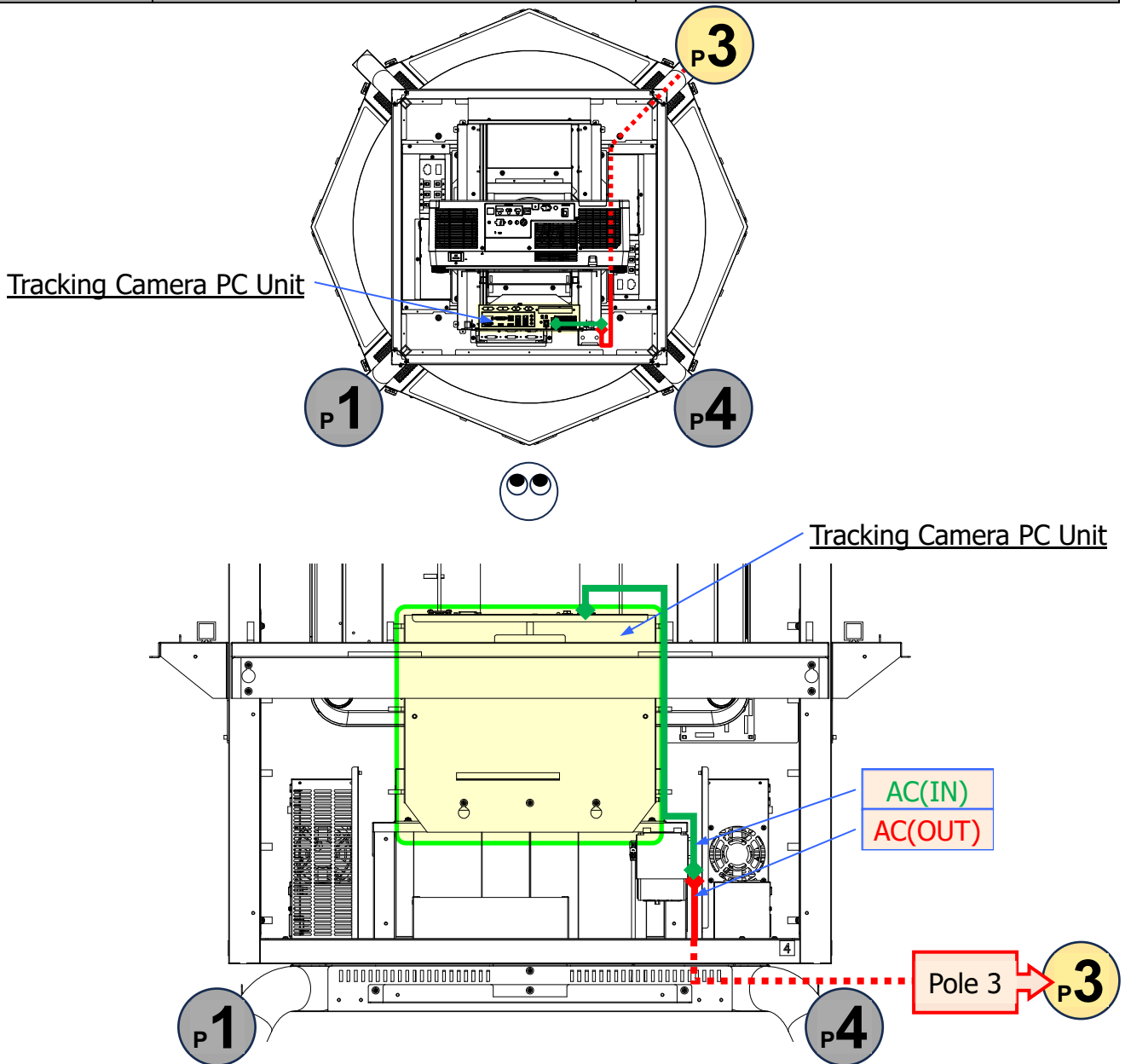

9. Connect the [USB],[DVI2],[CM3(PC)] Connectors of Pole 4 to the [USB],[DVI2],[PC] Connectors that were connected to the Tracking Camera PC at 3.2.1.2.

Pole No.	Connectors from Poles	Connectors of Top Base Unit
1		
2		
3		
4	[USB], [DVI2], [CM3(PC)]	[USB], [DVI2], [PC]

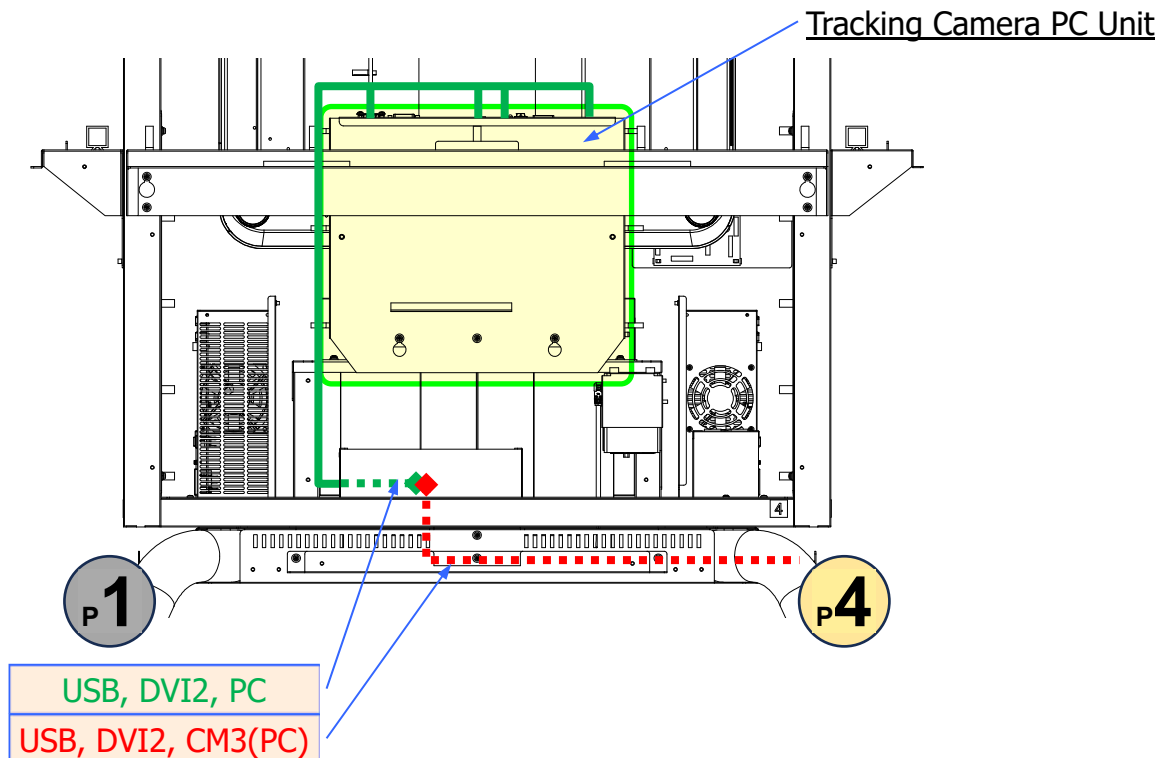
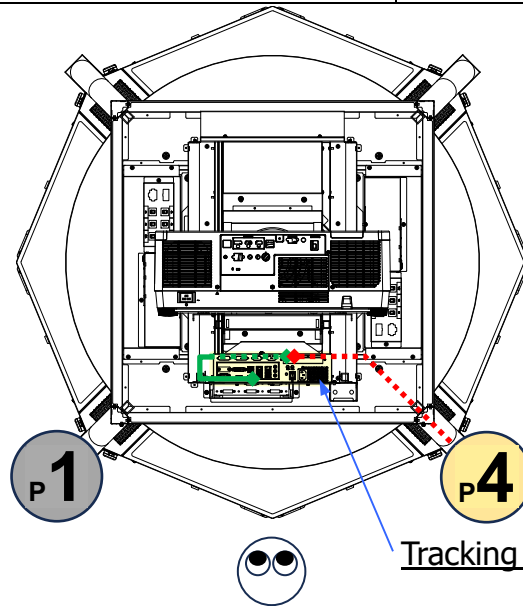

10. Connect the [LAN] Cable from the Pole 4 to the [LAN] Connector of the TINKER Unit, and then pull out the [CM] Connector of the [USB] Cable from to the TINKER Unit, by sliding it through the hole on the bottom side of the Pole Joint Base Unit, as indicated in the illustration below.

Pole No.	Connectors from Poles	Connectors of Top Base Unit
1	When not using TINKER Unit [USB Camera], skip STEP 10.	
2		
3		
4	[LAN]	[USB]

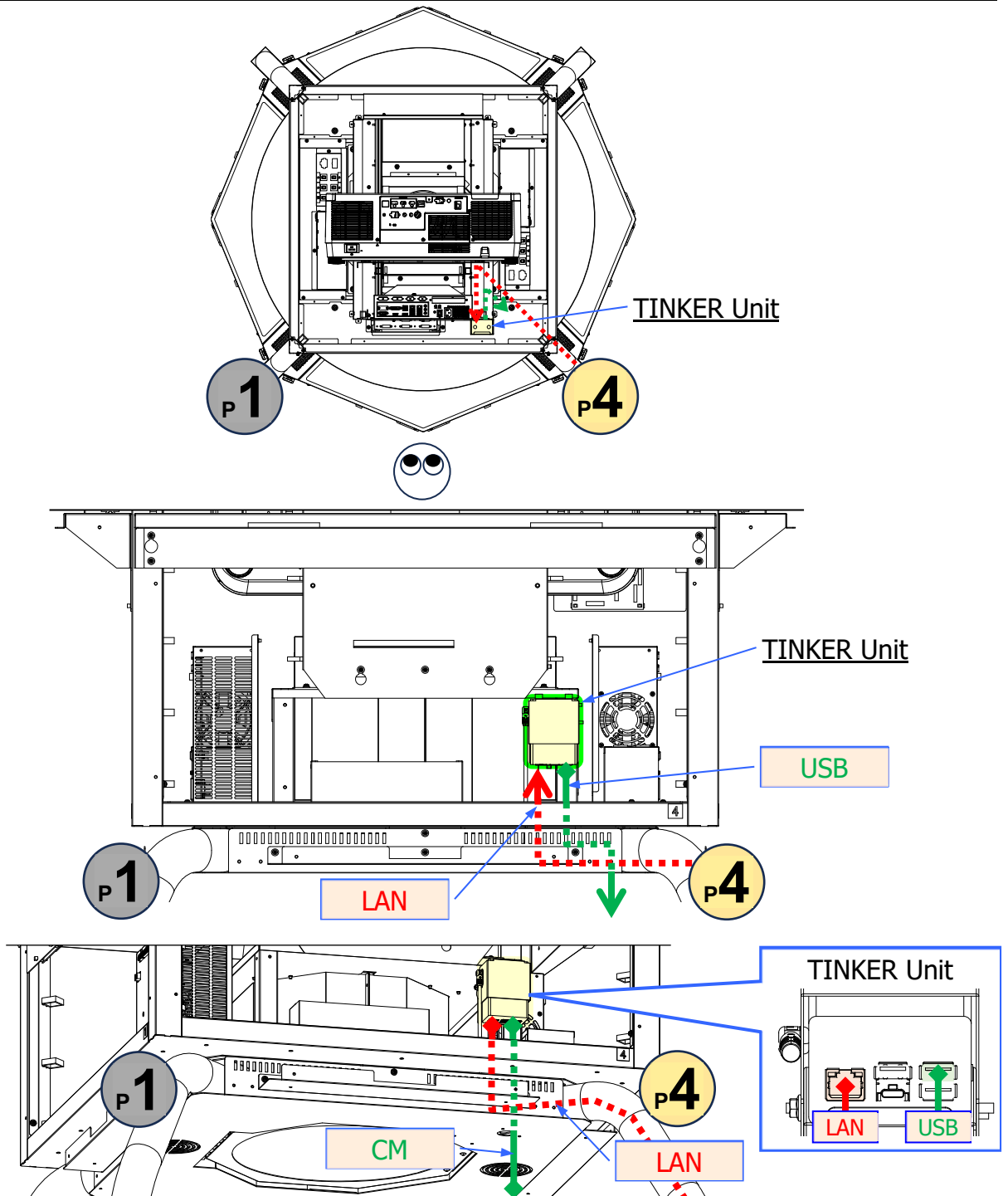

11. Connect the [FR] Connector of the Pole 1 to the [FR] connector from the Top PCB Box.

Pole No.	Connectors from Poles	Connectors of Top Base Unit
1	[FR]	[FR]
2		
3		
4		

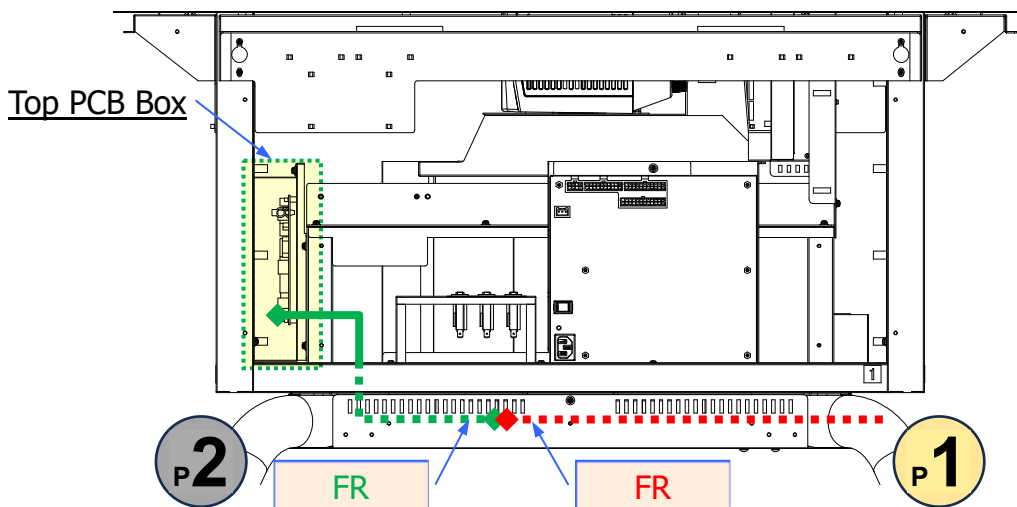
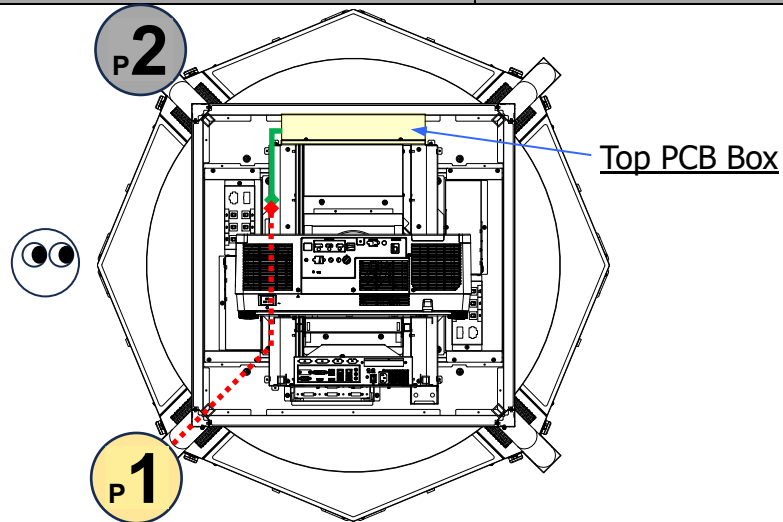

12. Remove 2 screws to detach the Top PCB Cover. Connect the [USB4(A)] Connector of Pole 2 to the [USB] Connector of the SIG A PCB, and the [USB 5(B)] Connector to the [USB] Connector of SIG B PCB.

Pole No.	Connectors from Poles	Connectors of Top Base Unit
1		
2	[USB 4(A)], [USB 5(B)]	[USB] of SIG A and SIG B PCBs
3		
4		

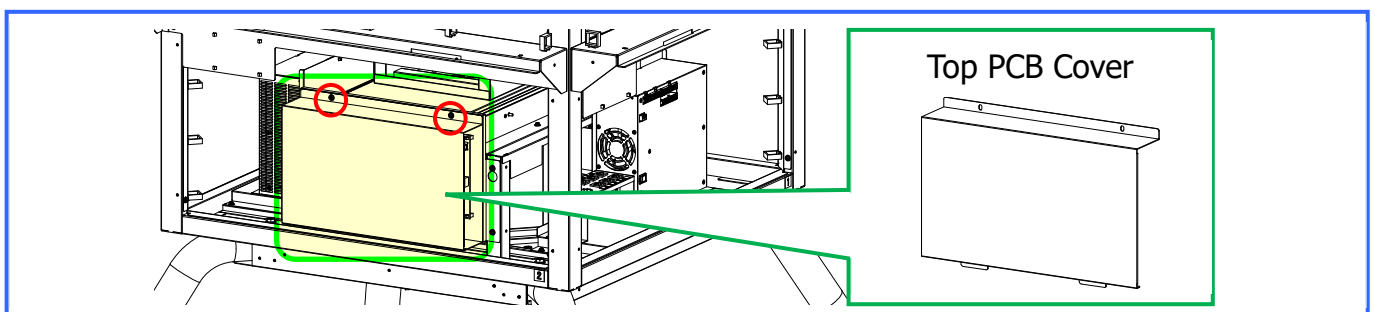
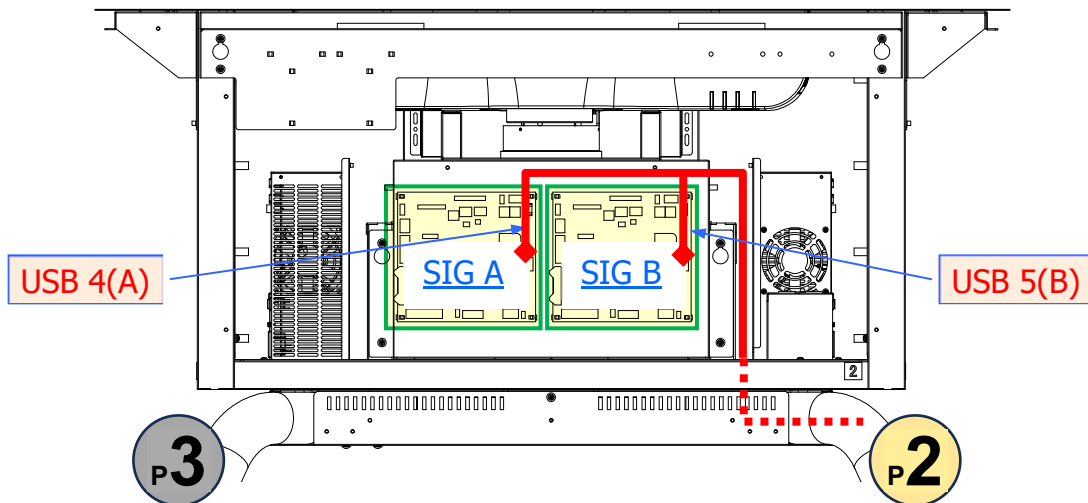
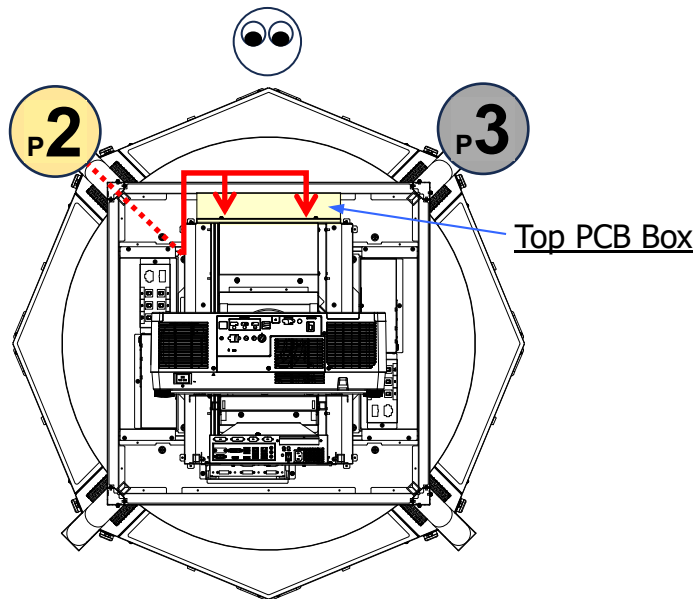

13. Connect the [AC (Out)] cable from Pole 3 to the [INLET] connector of the Power Box A.

Pole No.	Connectors from Poles	Connectors of Top Base Unit
1		
2		
3	[AC(OUT)]	[INLET] of the Power Box A
4		

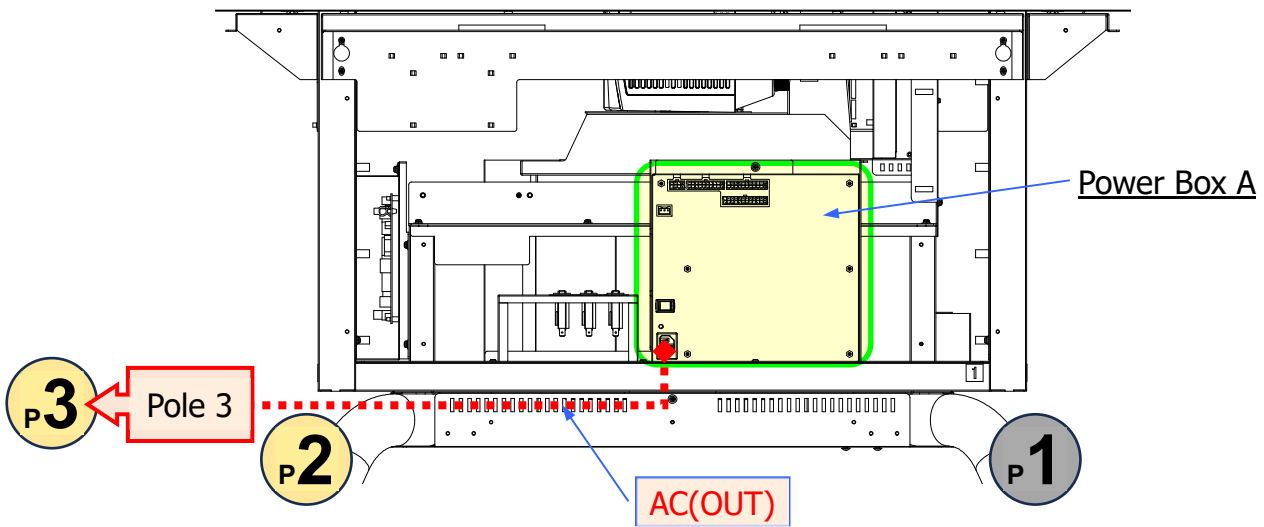
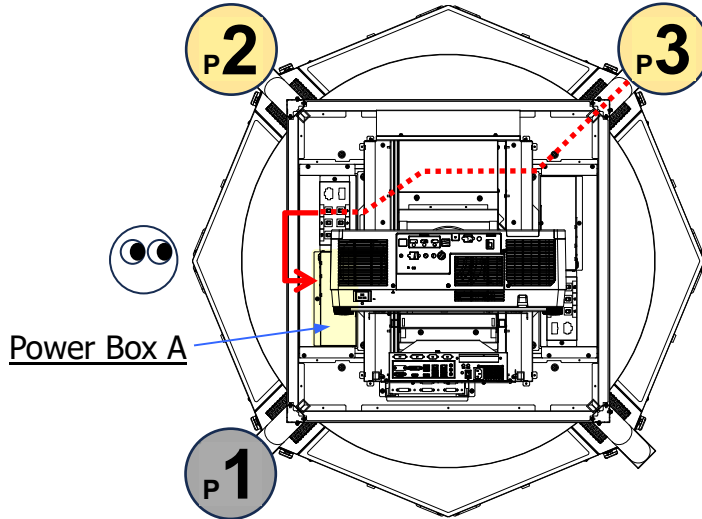

14. Connect the [AC (Out)] cable from Pole 3 to the [INLET] connector of the Power Box B.

Pole No.	Connectors from Poles	Connectors of Top Base Unit
1		
2		
3	[AC(OUT)]	[INLET] of the Power Box B
4		

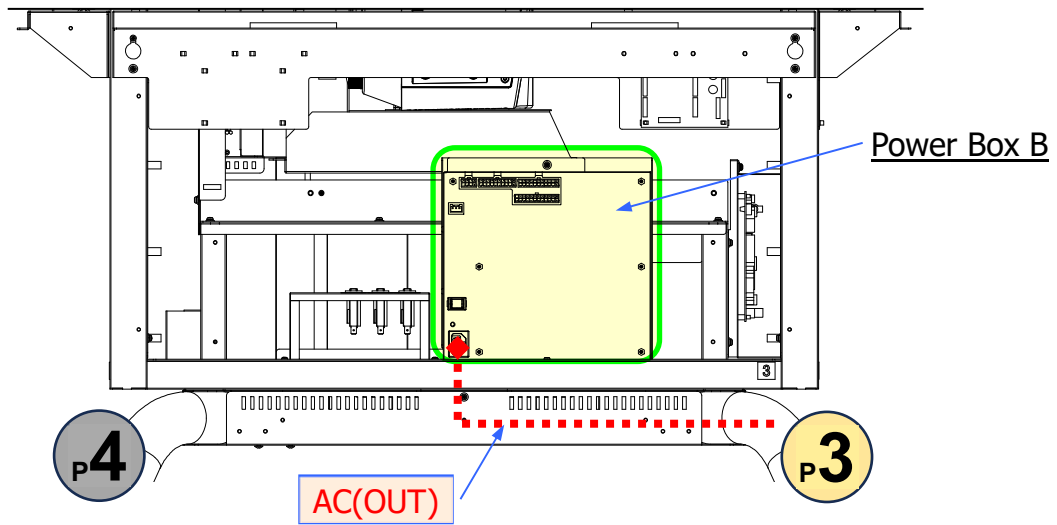
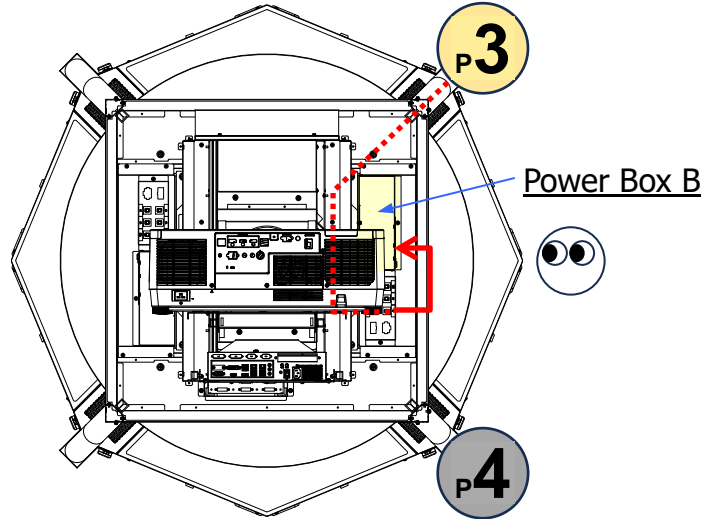

15. Refer to the illustration below and push the [I/O](⇔ [DC] ⇔ [12V] ⇔ [P12]) connector that is connected to the Breaker Unit of the Power Box B, inside the Pole 4. Then pull them out through the hole at the bottom of the Pole Joint Base Unit, together with the [LAN] Cable that was preliminarily laid.

Pole No.	Connectors from Poles	Connectors of Top Base Unit
1	When using TINKER Unit [USB Camera] (refer to STEP 10), skip STEP 15.	
2		
3		
4		[I/O]

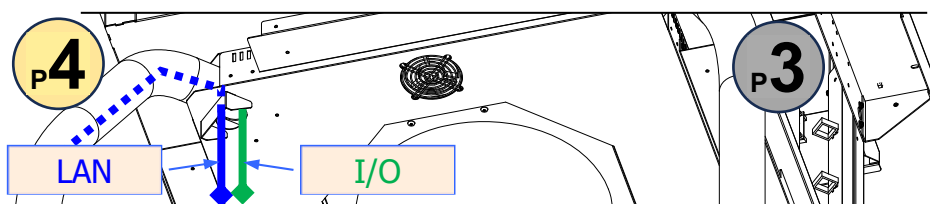
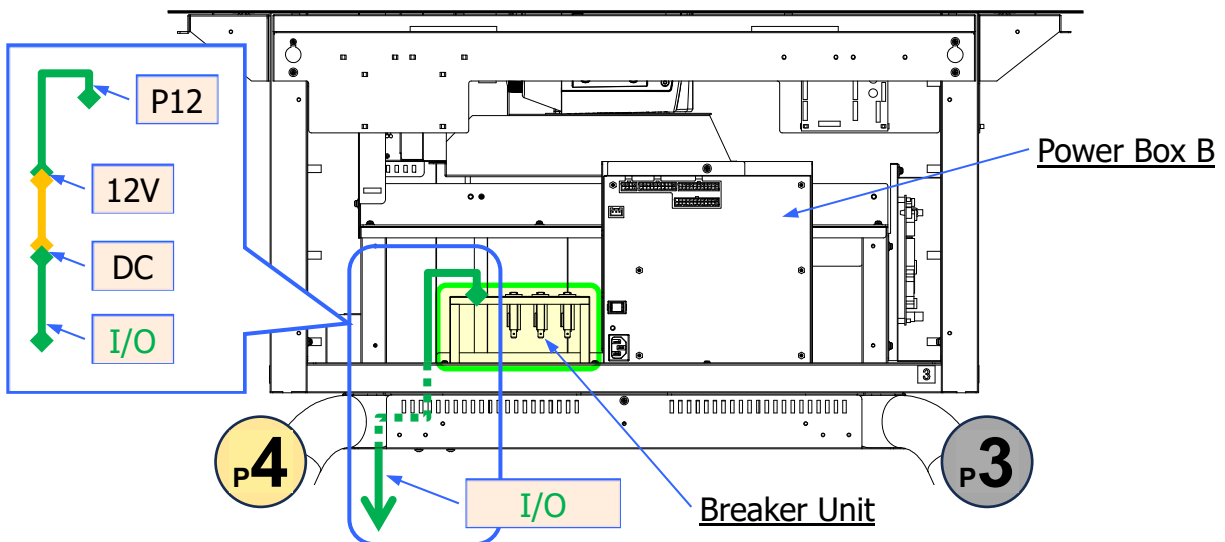
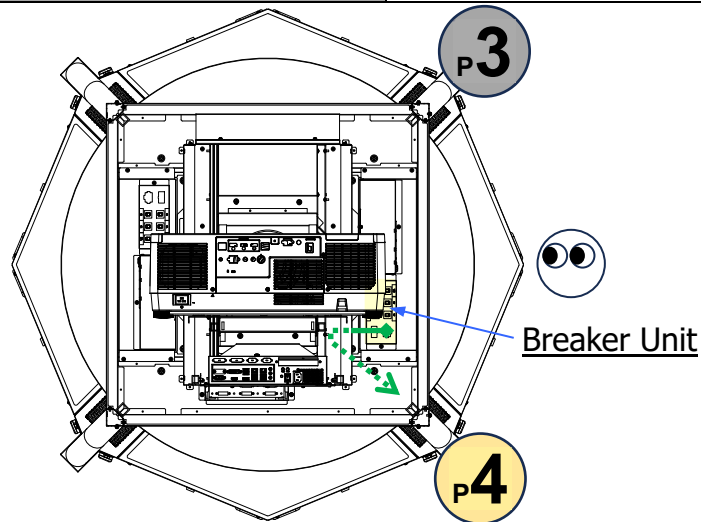

16. Refer to the illustration below to connect the [CF1] and [CF2] connectors from the Breaker Unit of the Power Box A, to the connectors of the FANs that are located below the Power Box A and Power Box B.

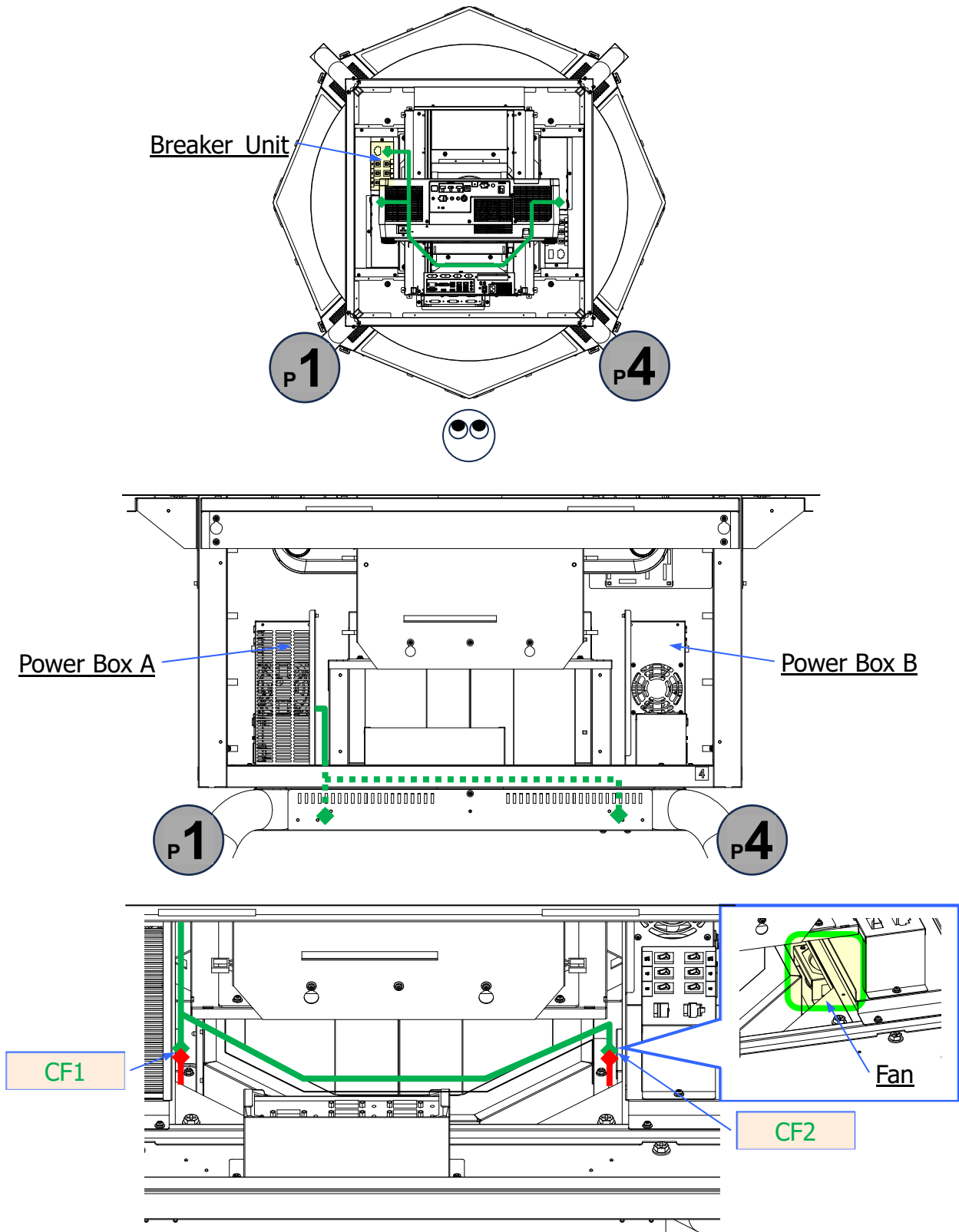

※All the connectors of the poles are now connected to the Top Base Unit.

3. 2. 1. 5: Preparing the Sign Unit(Installing Tower Light)

※ The Tower Light is an optional part. Skip this paragraph if it is not necessary.

i NOTE:

The target Sign Unit is the one where the Tower Light Plate is installed.

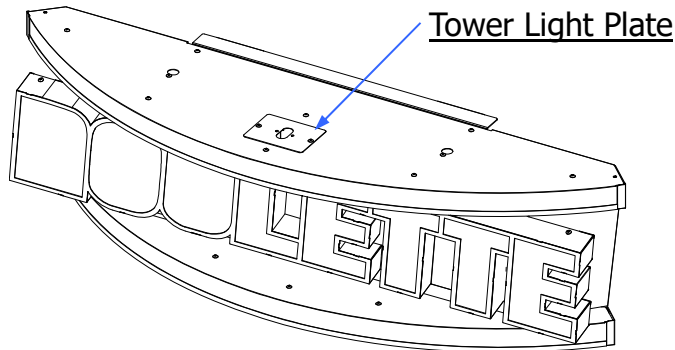

1. Prepare the following Parts.

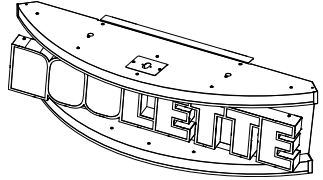
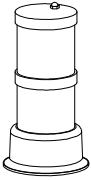
Parts Name	Qty	Appearance
Sign A Unit (for Tower Light)	2	
Tower Light	2	

2. Detach the Tower Light Plate by removing the 2 screws.

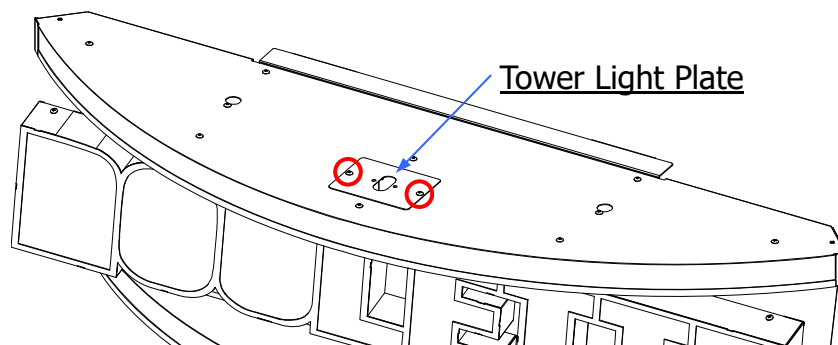

3. Thread the Tower Light Cable through the hole on the Tower Light Plate, and then affix the Tower Light by using the 2 screws (UNC#8-32-X5/8) that are included with the Tower Light.
4. Affix the Earth Cable Terminal of the Tower Light on the stud located on the inner side of the Tower Light Plate, by using the nut M4 flange.

Fasteners		Qty	Appearance
R	FLANGE NUT M4	2	

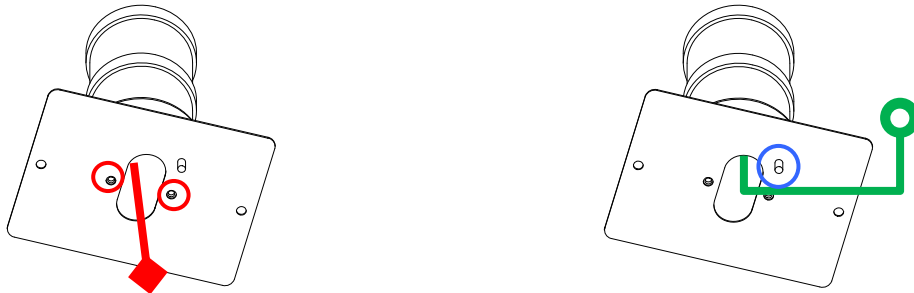

5. Return the Tower Light Plate to its original position and affix it by using screws.

i NOTE:

Make sure that the screw nut on the top of the Tower Light is located on the backside.

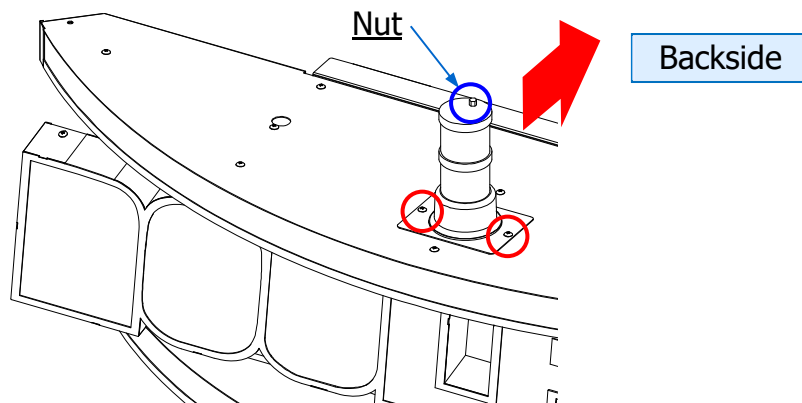

6. Connect the connector of the Tower Light to the [TLO] connector inside the Sign Unit.

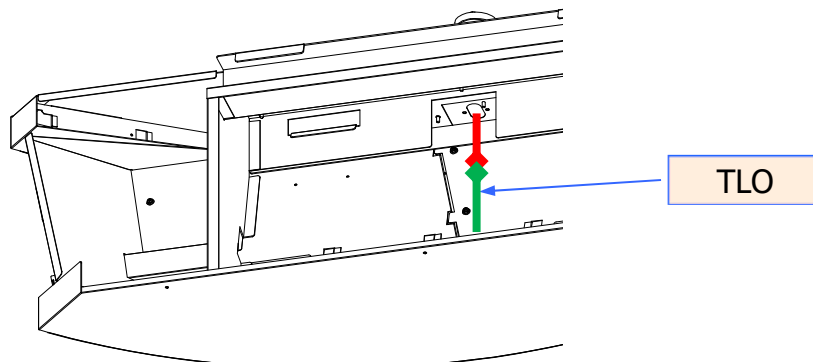

3. 2. 1. 6: Installing the Sign Unit(with Tower) onto the Top Base Unit

1. Prepare the following Parts.

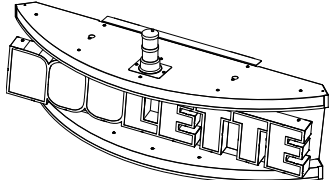
Parts Name	Qty	Appearance
Sign A Unit (Assembled in 3.2.1.5)	2	

2. Install the Sign A Units to the frame of the Top Base Unit, on the sides of the Power Box A and on the side of the Power Box B.

Before the procedure check the Cables from the Top Base Unit and the Sign A Unit, and arrange them so that they will not get in the way during the next procedures.

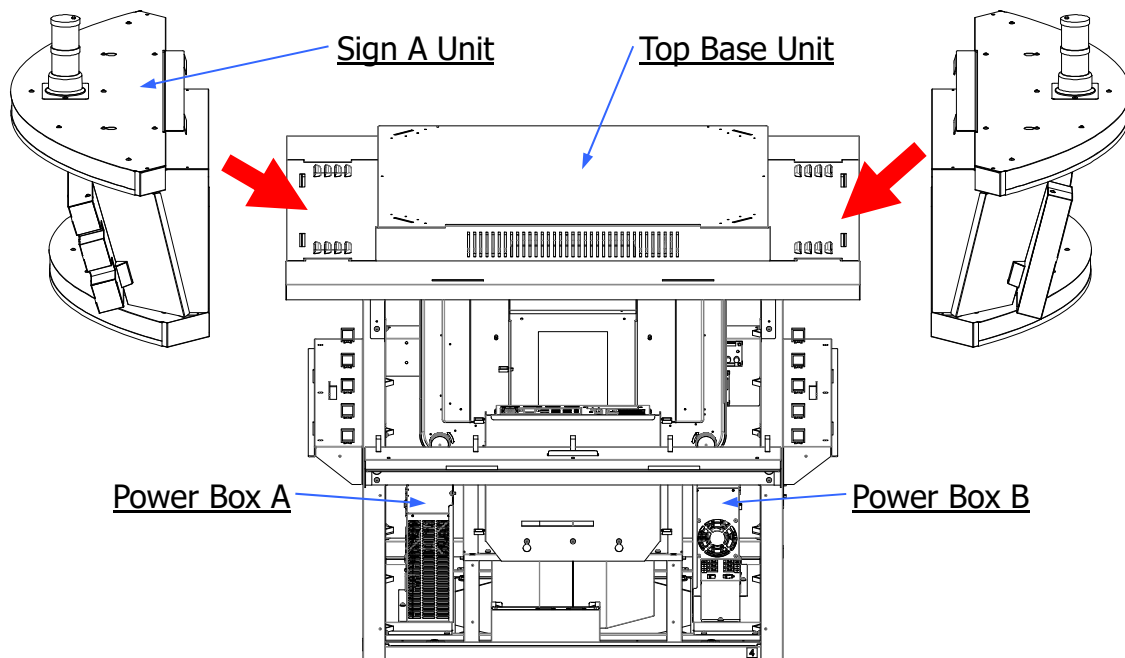

3. Install the Sign A Unit to the frame of the Top Base Unit on the side of Power Box A (between Pole 1 and Pole 2). Hang the hooks on the back side of the Sign A Unit to the slits.

! CAUTION!

- Once the installing procedure is started, never let go of the Sign A Unit until it is affixed to the Top Base Unit.
- Since the operation will be performed in a high place, pay enough attention also to the safety of the surrounding area.

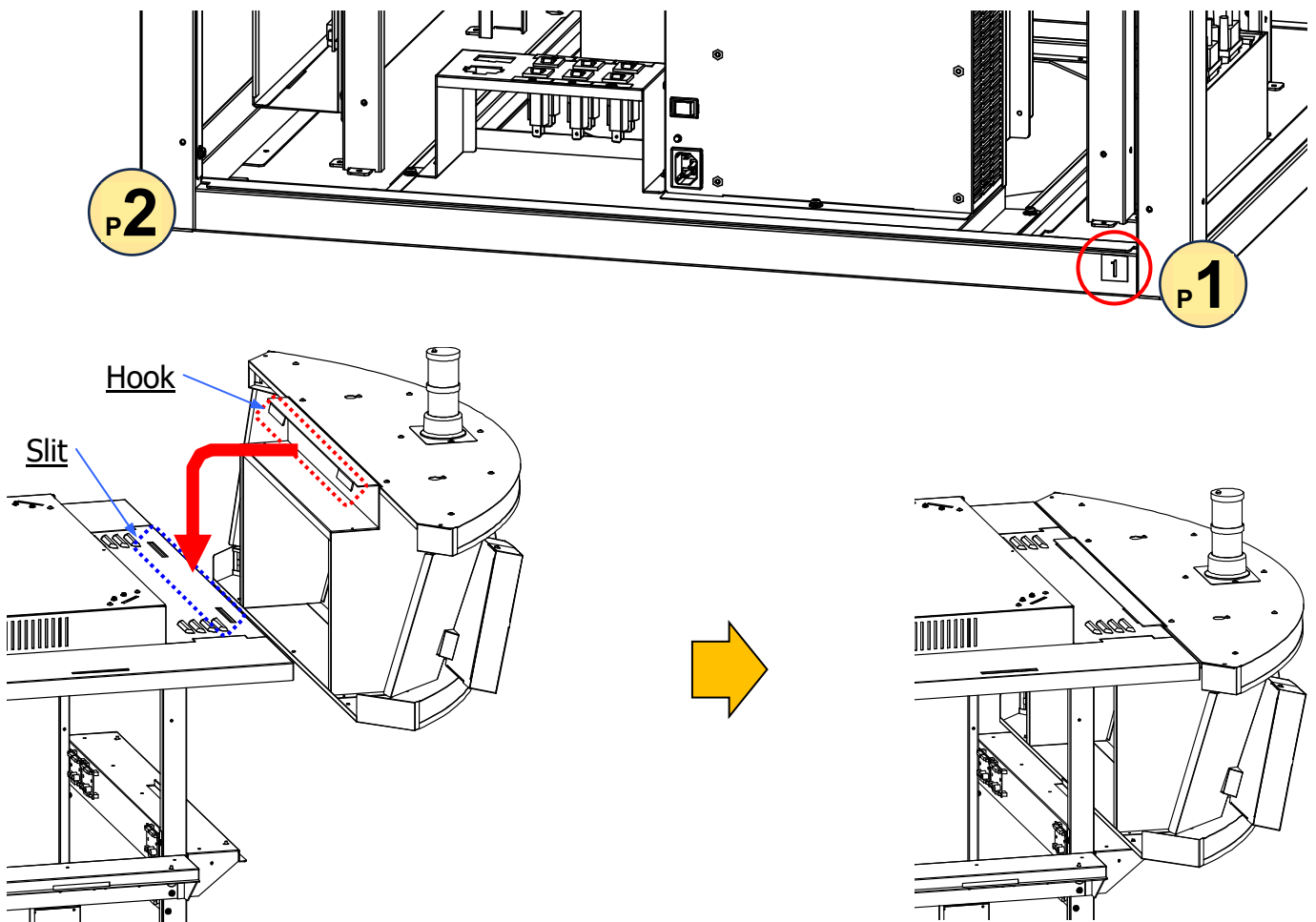

4. Affix the Sign A Unit from the lower side by using 3 screws.

Fasteners		Qty	Appearance
F	PAN M4x8 3P	3	

**CAUTION!**

Make sure that the hooks where the Sign Unit is hung to, do not slip while you are fixing the screws.

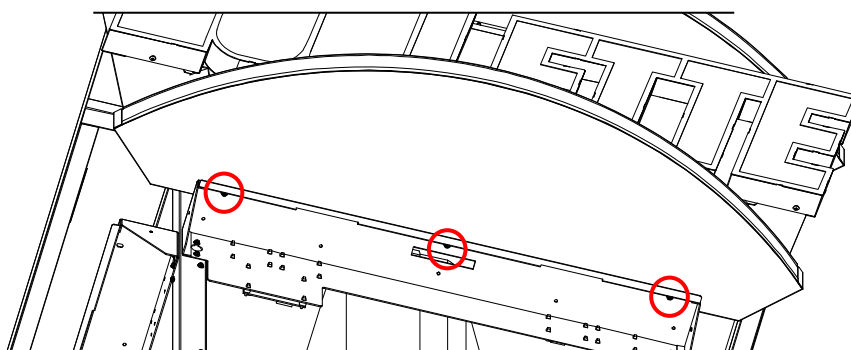

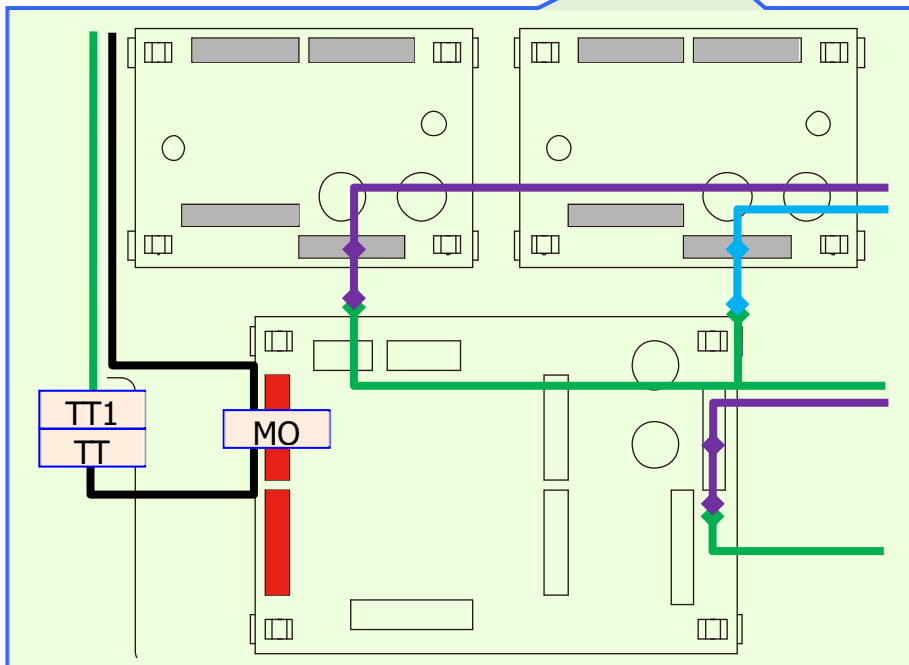
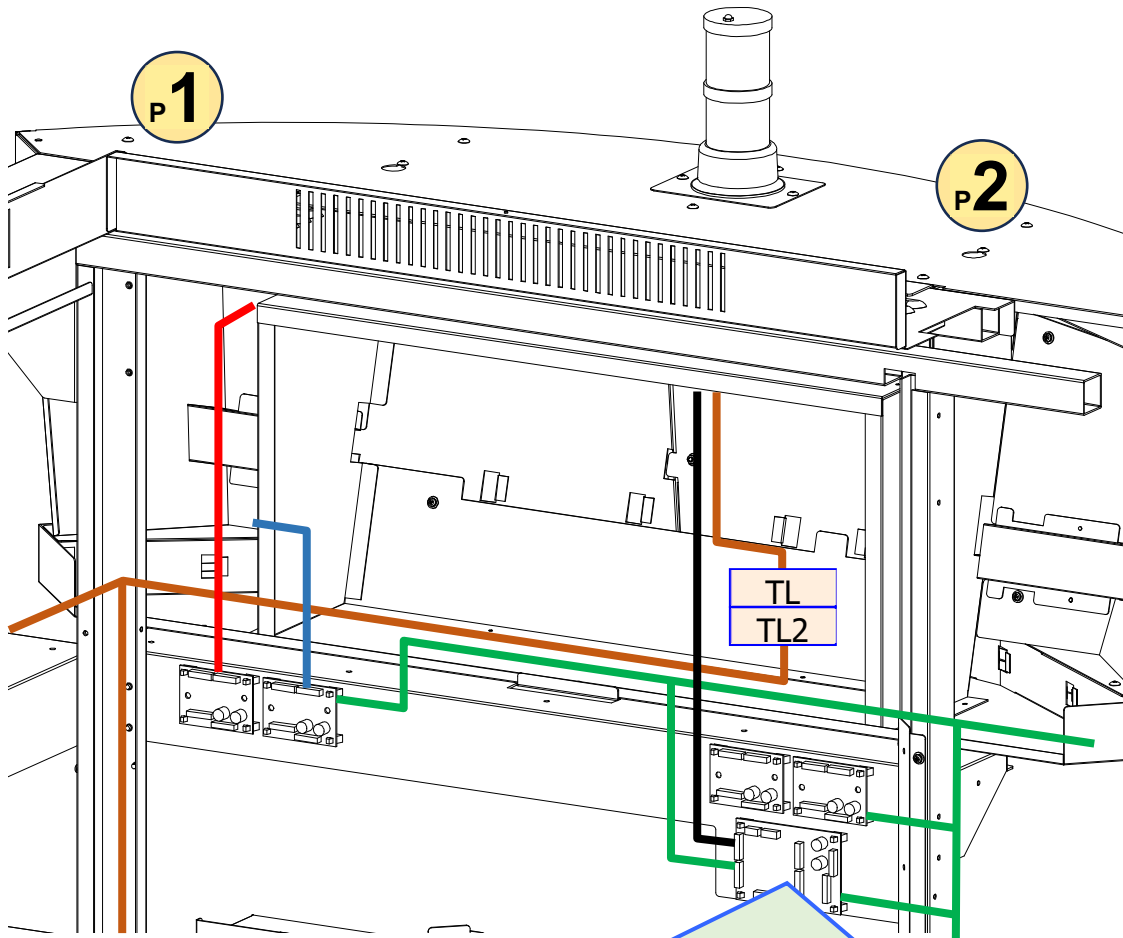



6. Install the Sign A Unit to the frame of the Top Base Unit on the side of Power Box B (between Pole 3 and Pole 4). Hang the hooks on the back side of the Sign A Unit to the slits.

! CAUTION!

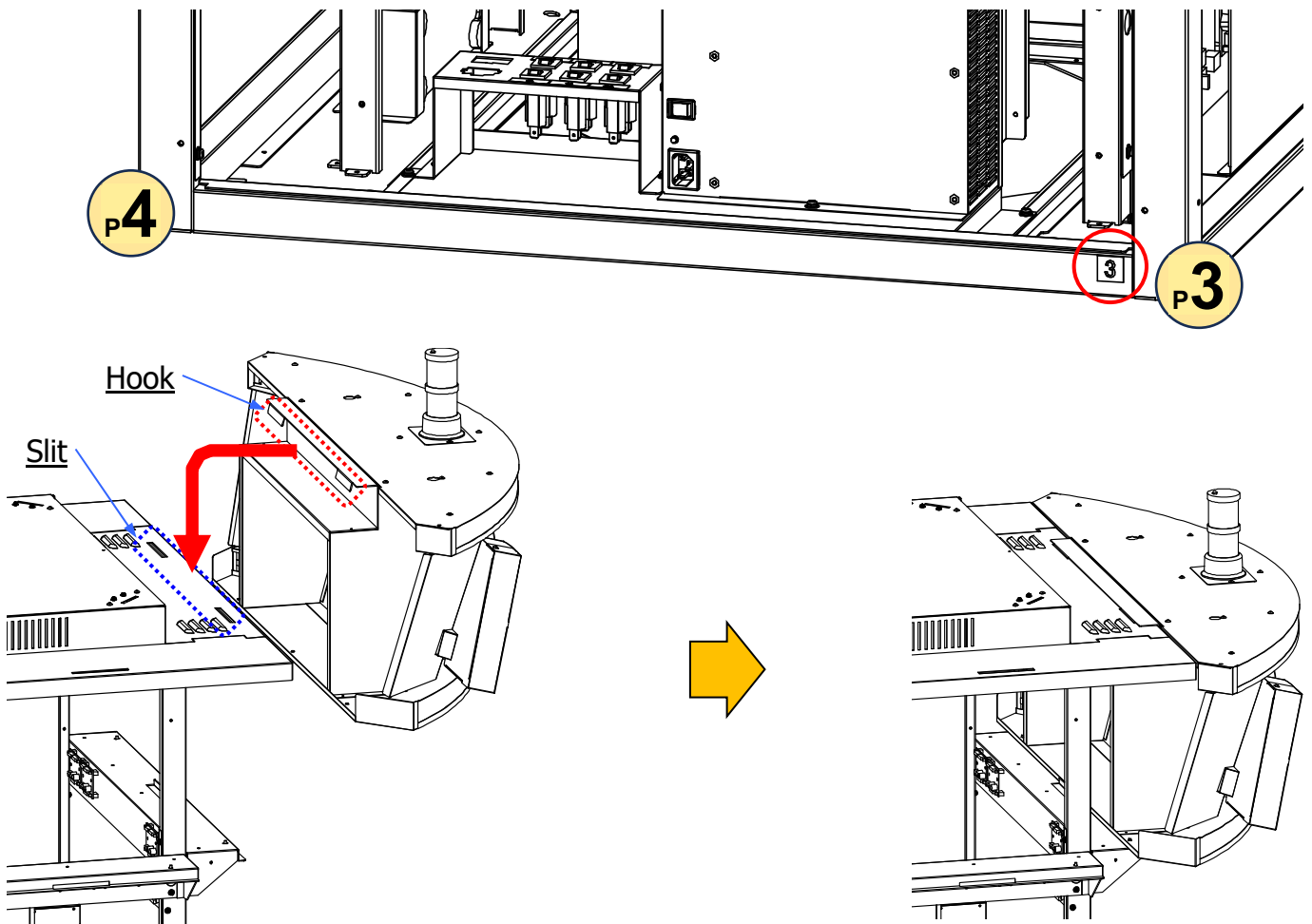
- Once the installing procedure is started, never let go of the Sign A Unit until it is affixed to the Top Base Unit.
- Since the operation will be performed in a high place, pay enough attention also to the safety of the surrounding area.



7. Affix the Sign A Unit from the lower side by using 3 screws.

Fasteners		Qty	Appearance
F	PAN M4x8 3P	3	

**CAUTION!**

Make sure that the hooks where the Sign Unit is hung to, do not slip while you are fixing the screws.

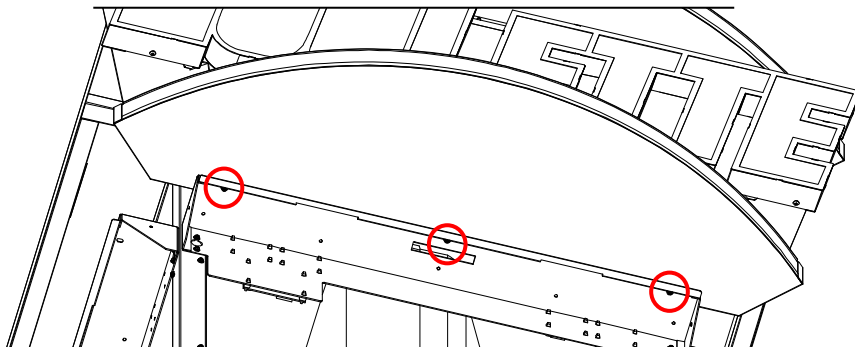

- Refer to the images below and connect the connectors of the Sign A Unit that was just installed.

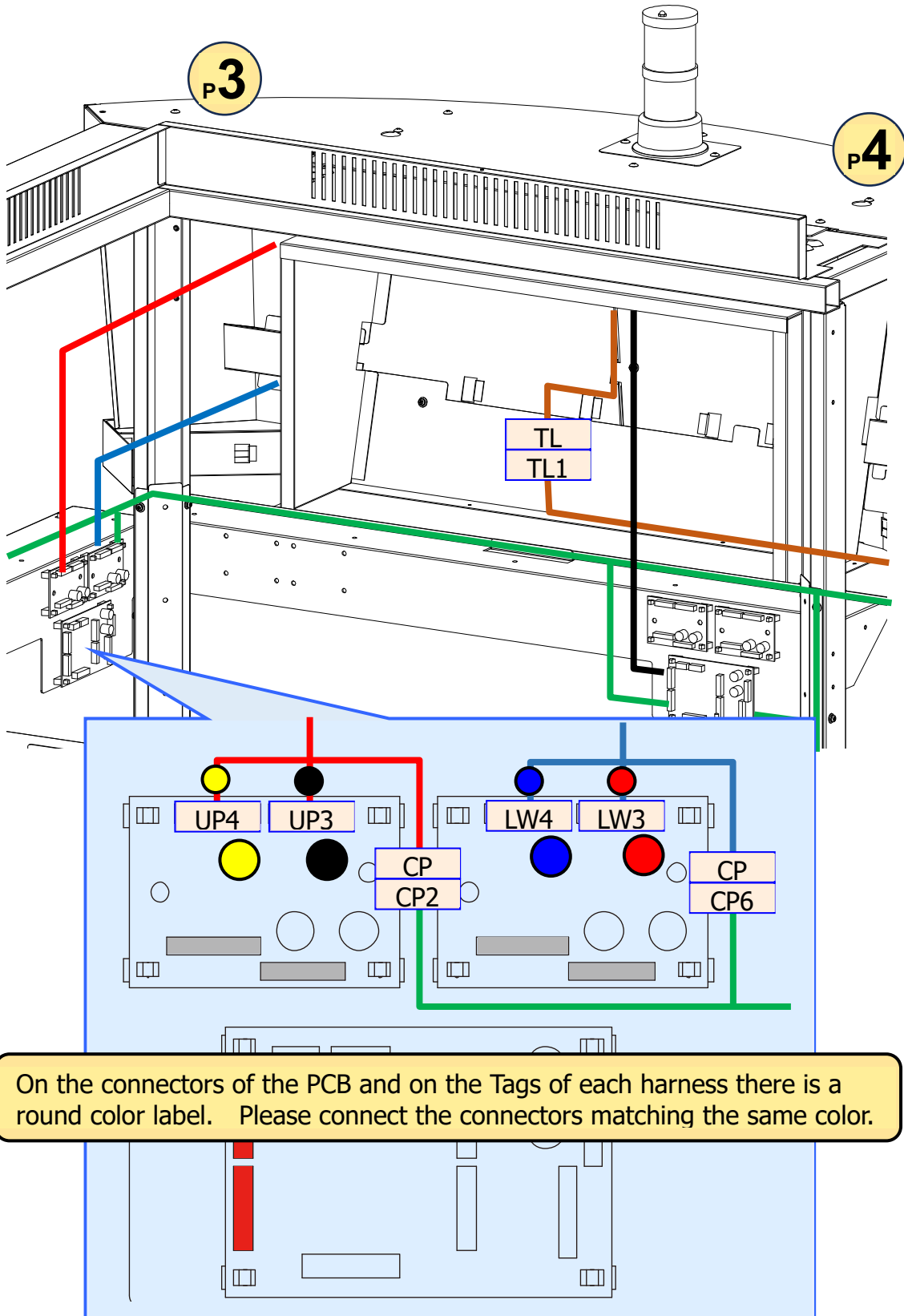

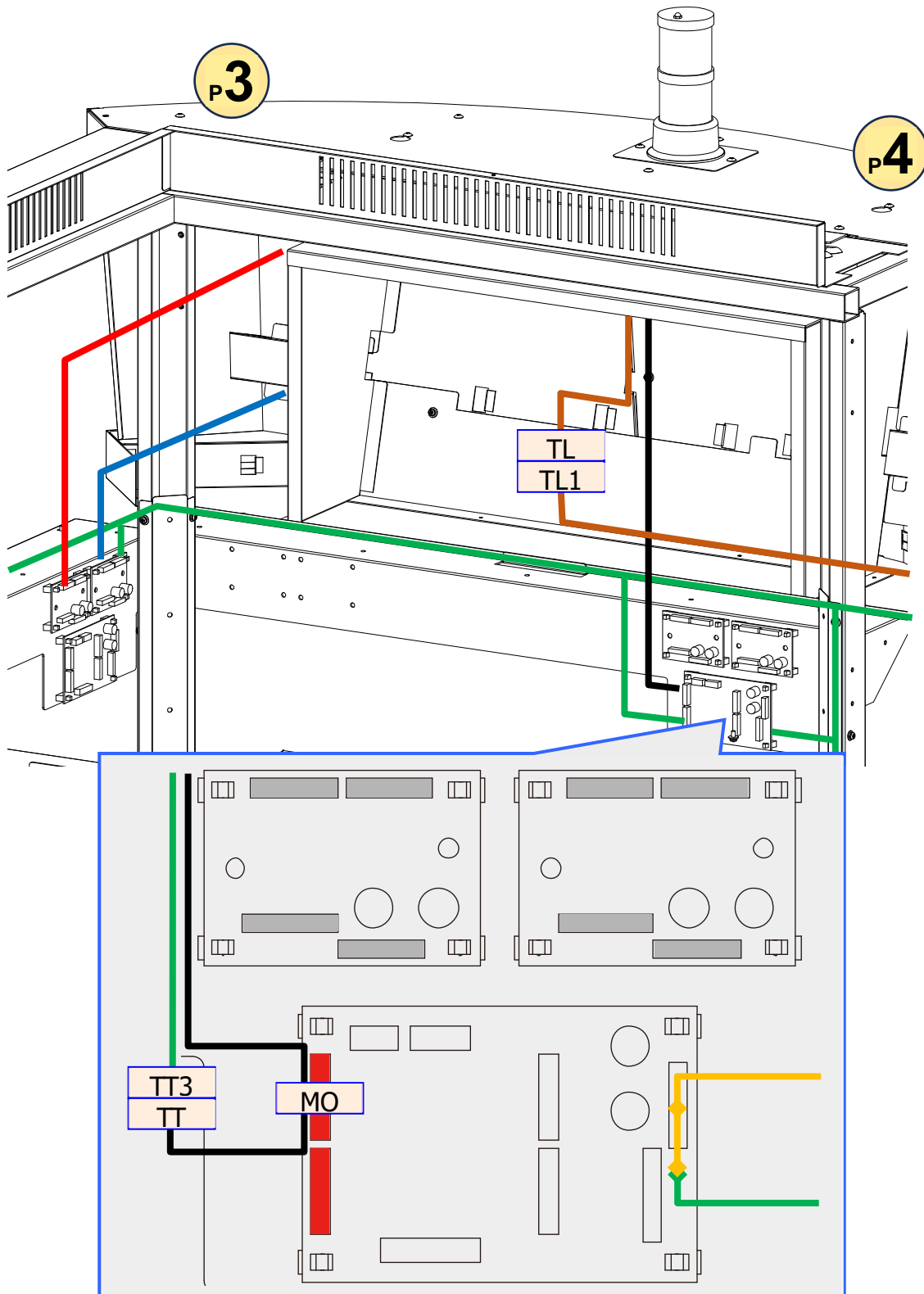

3. 2. 1. 7: Installing the Sign Unit(No Tower) onto the Top Base Unit

1. Prepare the following Parts.

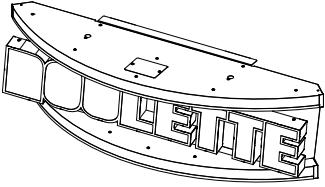
Parts Name	Qty	Appearance
Sign B Unit	2	

2. Install the Sign B Units to the frame of the Top Base Unit, on the sides of the Top PCB Box and on the side of the DVI Splitter.

Before the procedure, check the cables of the Top Base Unit and of the Sign B Units. Arrange the cables so that they will not get in the way during the next procedures.

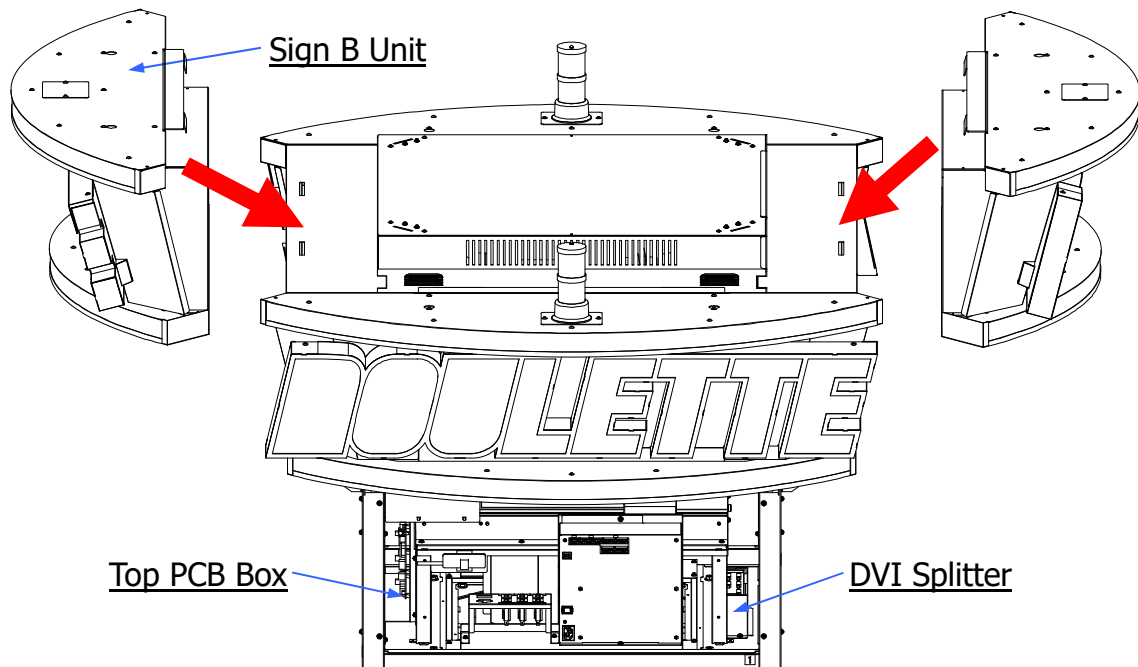

3. Install the Sign B Unit to the frame of the Top Base Unit on the side of Top PCB box (between Pole 2 and Pole 3). Hang the hooks on the back side of the Sign B Unit to the slits.

⚠ CAUTION!

- Once the installing procedure is started, never let go of the Sign B Unit until it is affixed to the Top Base Unit.
- Since the operation will be performed in a high place, pay enough attention also to the safety of the surrounding area.

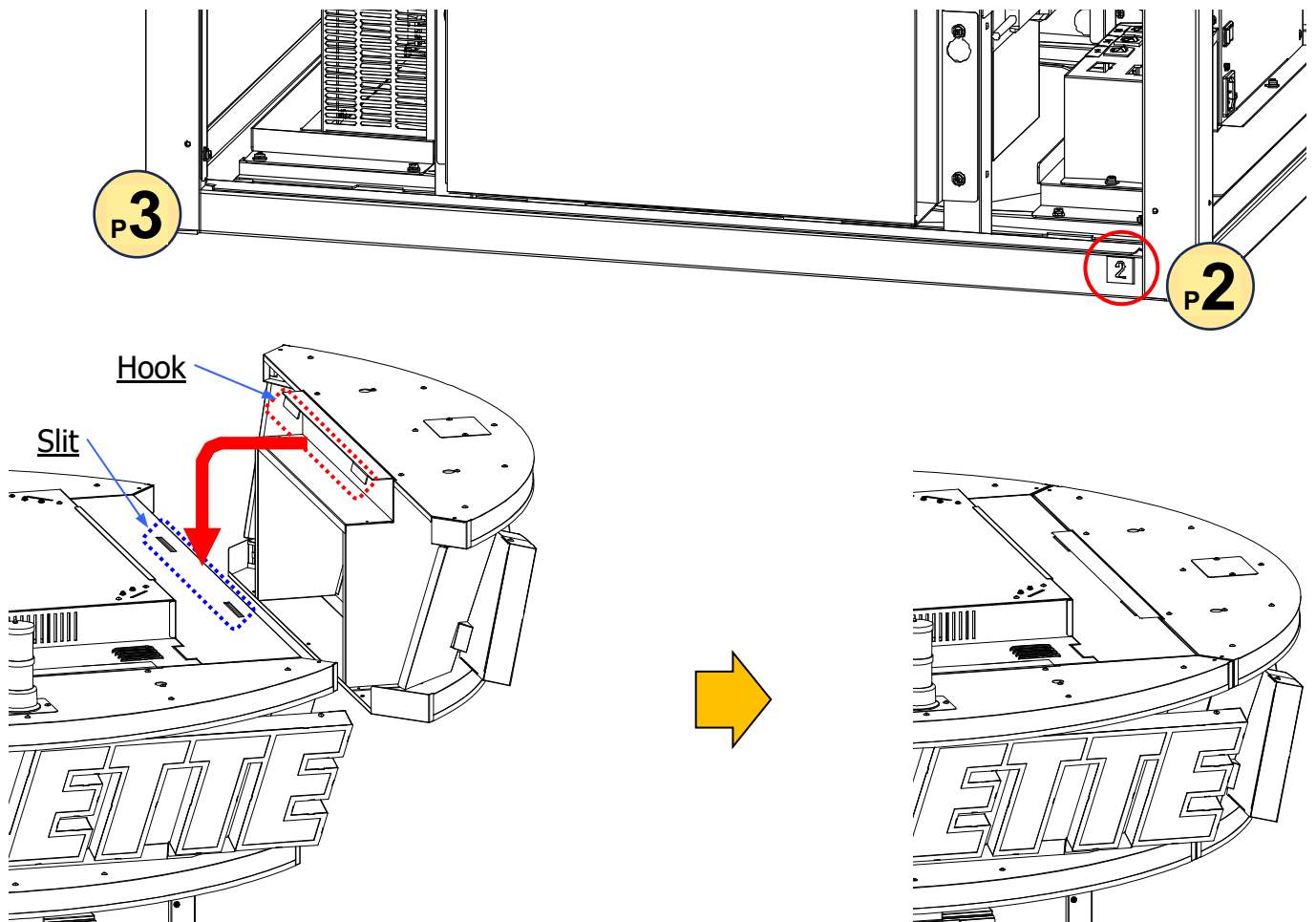

4. Affix the Sign B Unit from the lower side by using 3 screws.

Fasteners		Qty	Appearance
F	PAN M4x8 3P	6	

**CAUTION!**

Make sure that the hooks where the Sign Unit is hung to, do not slip while you are fixing the screws.

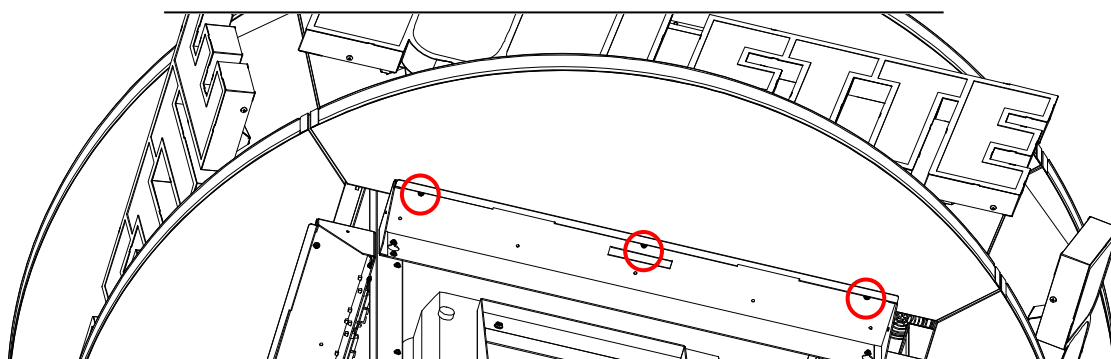

- Refer to the images below and connect the connectors of the Sign B Unit that was just installed.

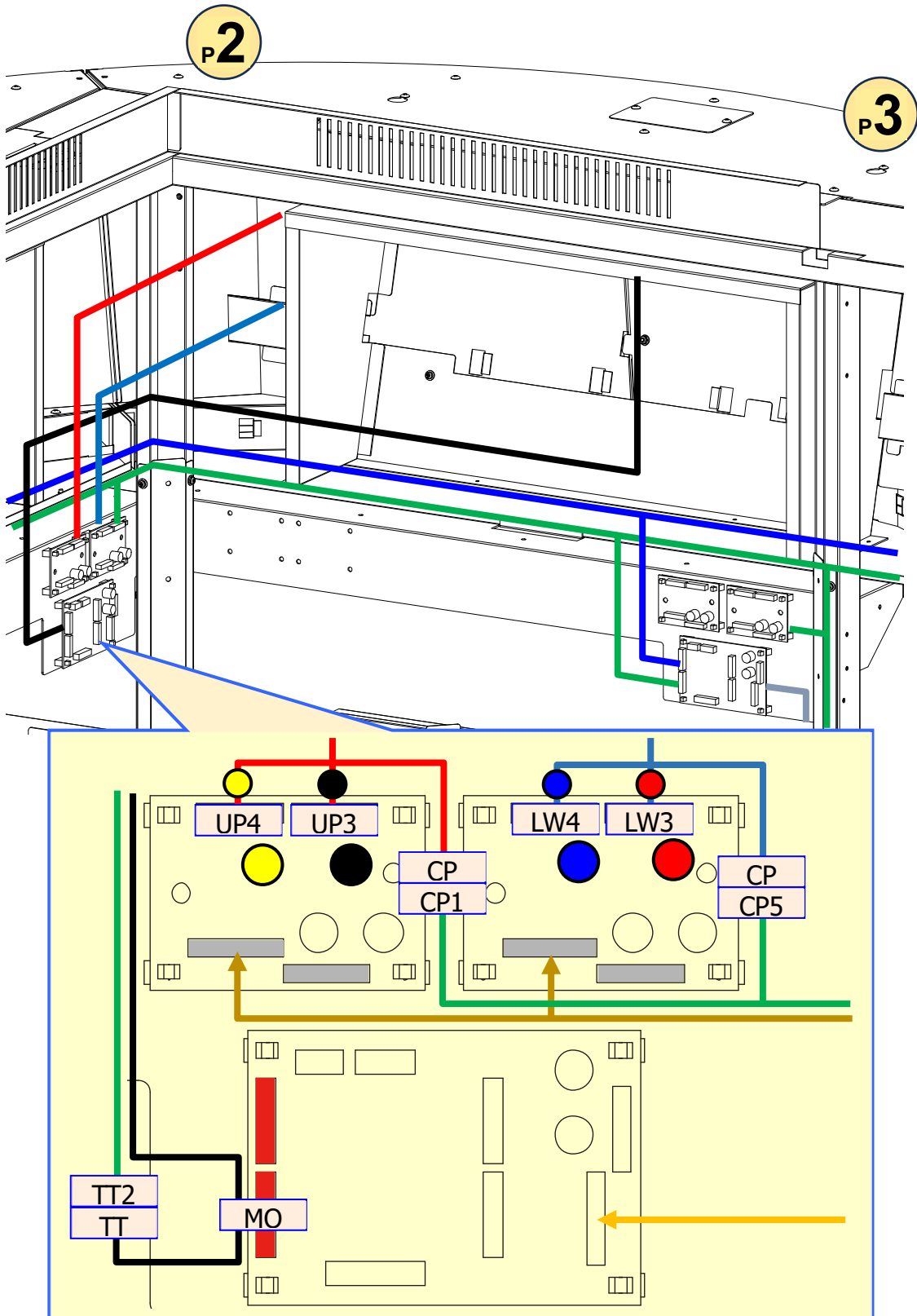

On the connectors of the PCB and on the Tags of each harness there is a round color label. Please connect the connectors matching the same color.

6. Install the Sign B Unit to the frame of the Top Base Unit on the side of DVI Splitter (between Pole 2 and Pole 3). Hang the hooks on the back side of the Sign B Unit to the slits.

! CAUTION!

- Once the installing procedure is started, never let go of the Sign B Unit until it is affixed to the Top Base Unit.
- Since the operation will be performed in a high place, pay enough attention also to the safety of the surrounding area.

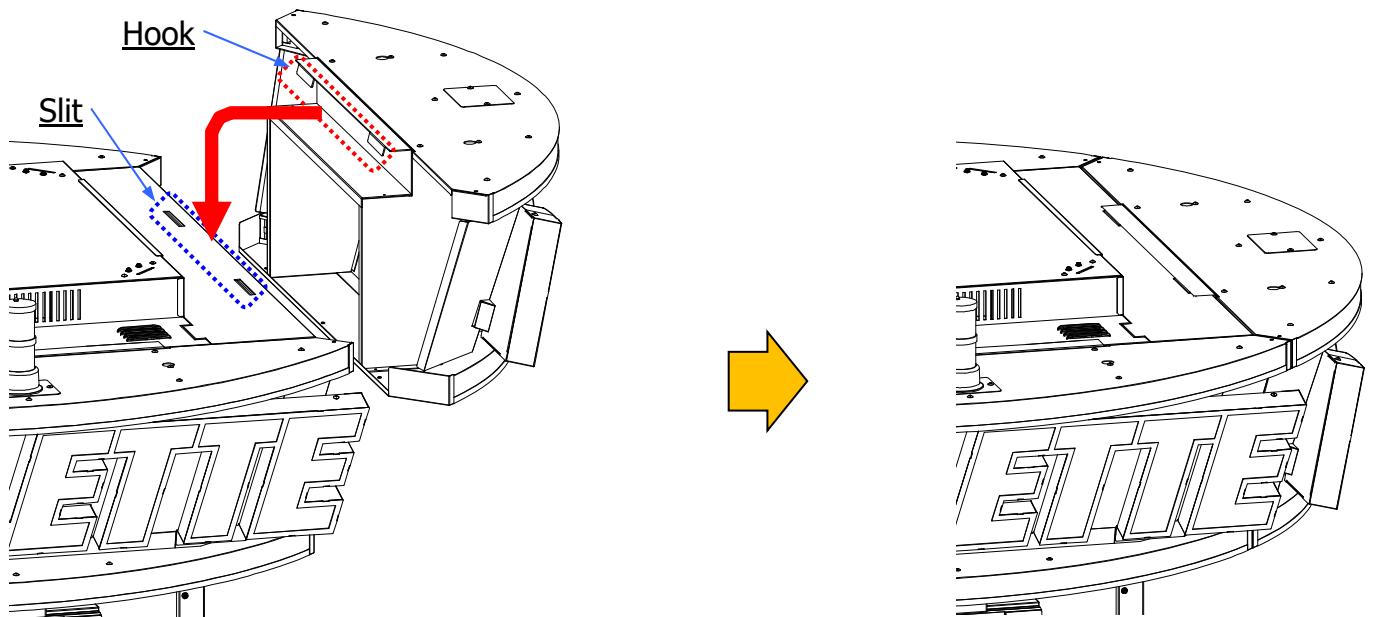
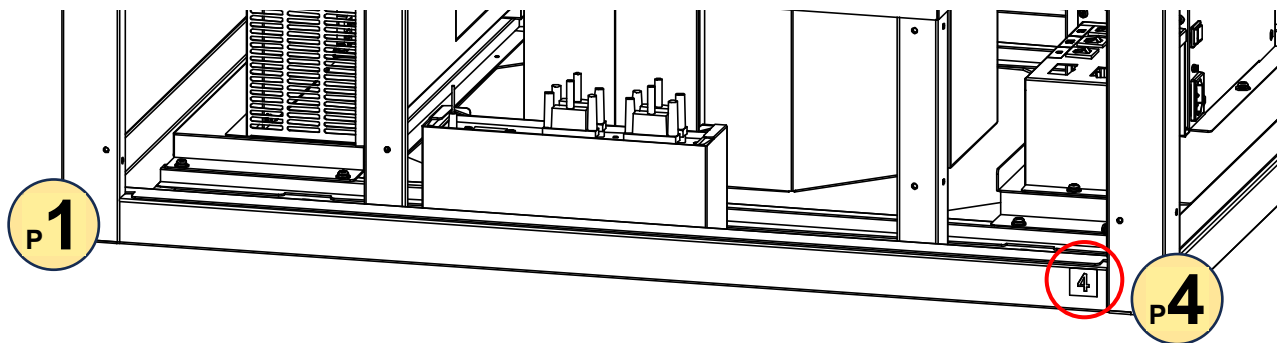

7. Affix the Sign B Unit from the lower side by using 3 screws.

Fasteners		Qty	Appearance
F	PAN M4x8 3P	6	

**CAUTION!**

Make sure that the hooks where the Sign Unit is hung to, do not slip while you are fixing the screws.

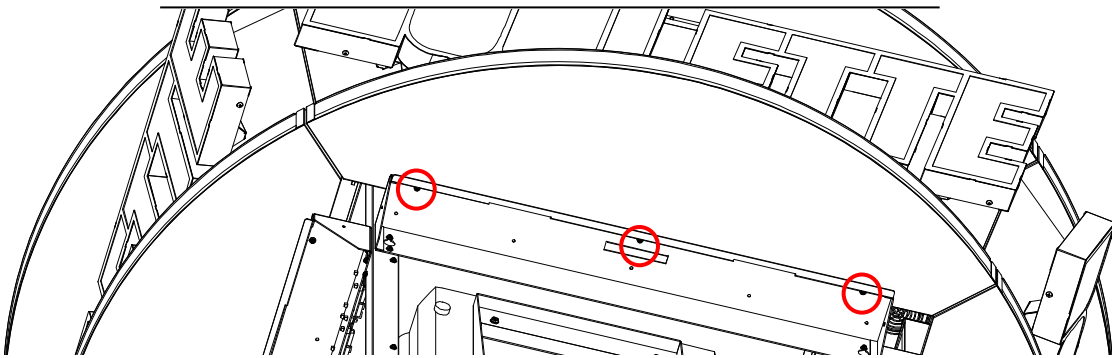

- Refer to the images below and connect the connectors of the Sign B Unit that was just installed.

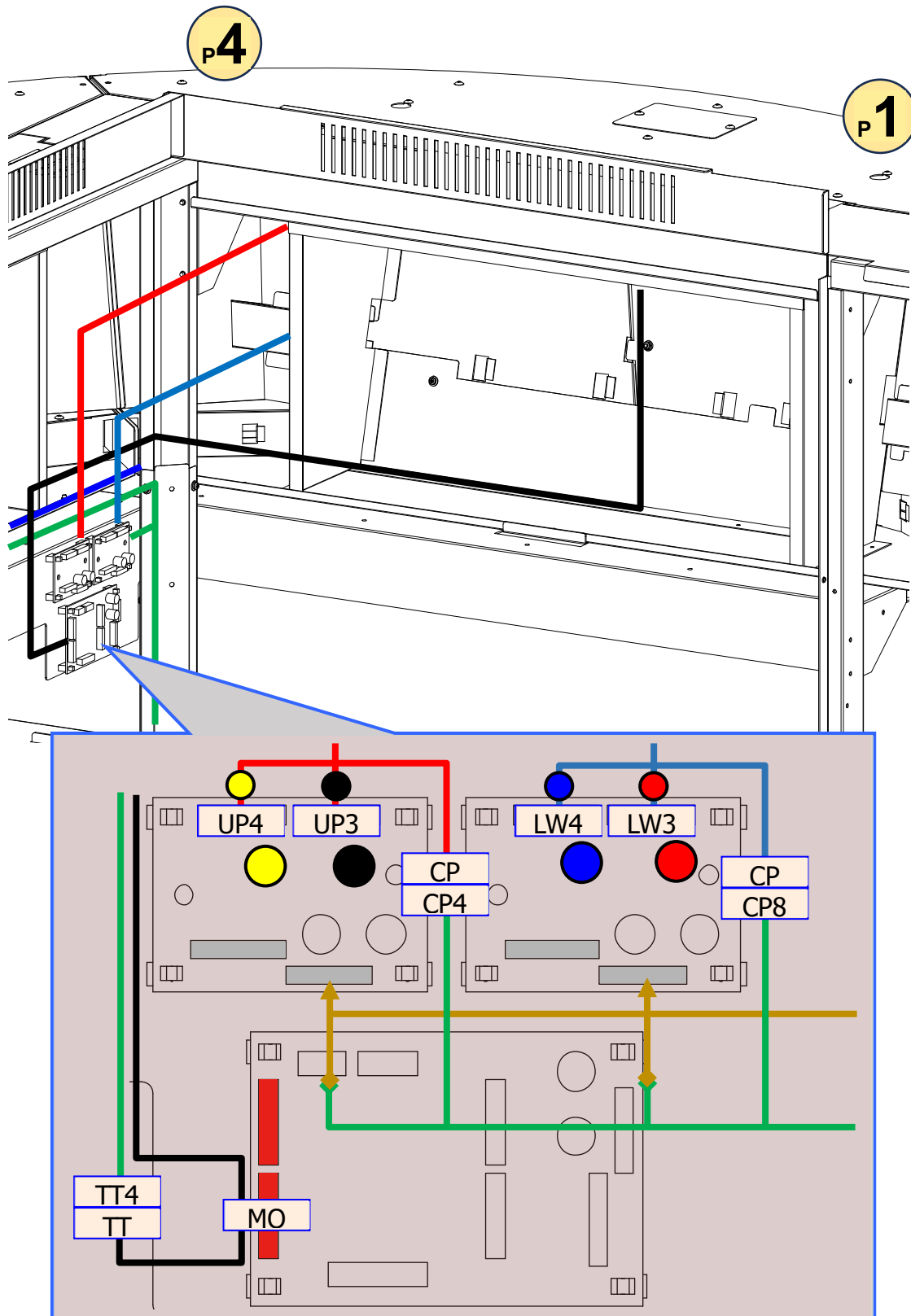

On the connectors of the PCB and on the Tags of each harness there is a round color label. Please connect the connectors matching the same color.

At this point the machine should look like this.

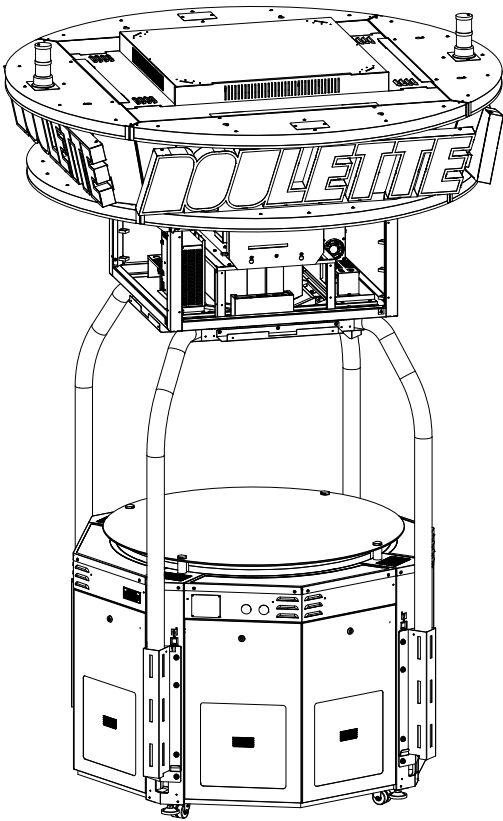

3. 2. 1. 8: Installing the Ring Units onto the Top Base Unit

1. Prepare the following Parts.

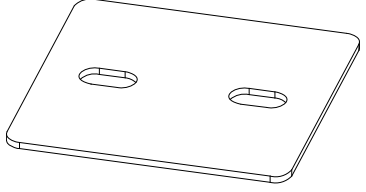
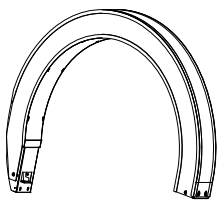
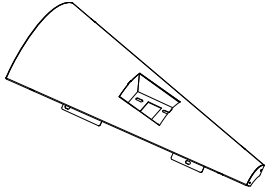
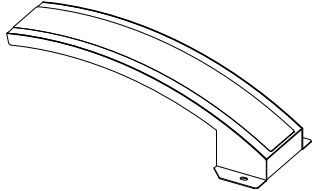
Parts Name	Qty	Appearance
Joint Plate	4	
Ring	4	
Ring Spacer	4	
Ring Cover	4	

2. Affix the Joint Plate onto the Top Base Units by using the 2 screws for each.

Fasteners	Qty	Appearance
Bb TRUSS M4x10 BLK	8	

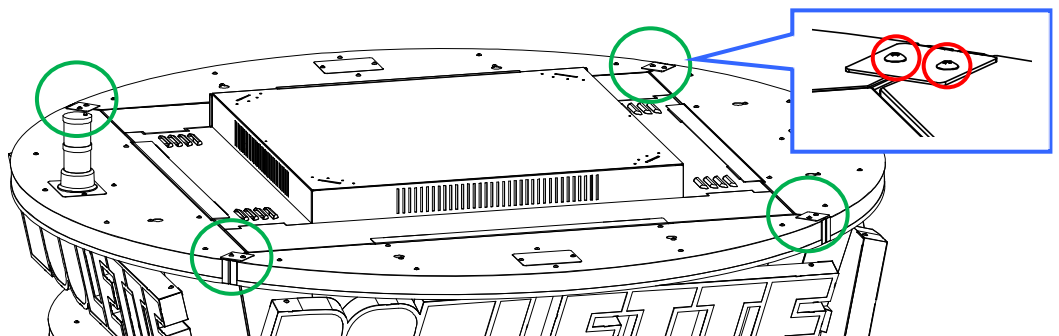

3. Affix a Ring Spacer to each Ring by using the 4 screws for each.

Fasteners		Qty	Appearance
F	PAN M4x8 3P	16	

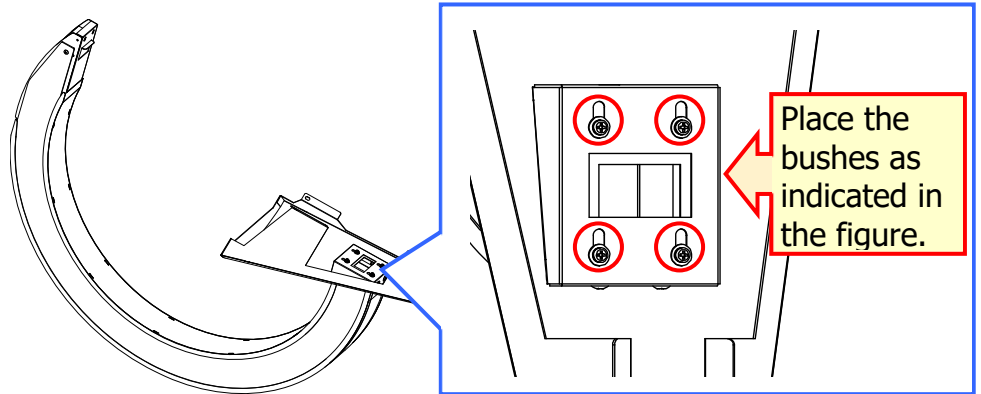

4. Insert the Hook of the Ring into the slit of the Top Base Unit to install the Ring Unit.

i NOTE:

Pay attention to the narrow parts to assembly.

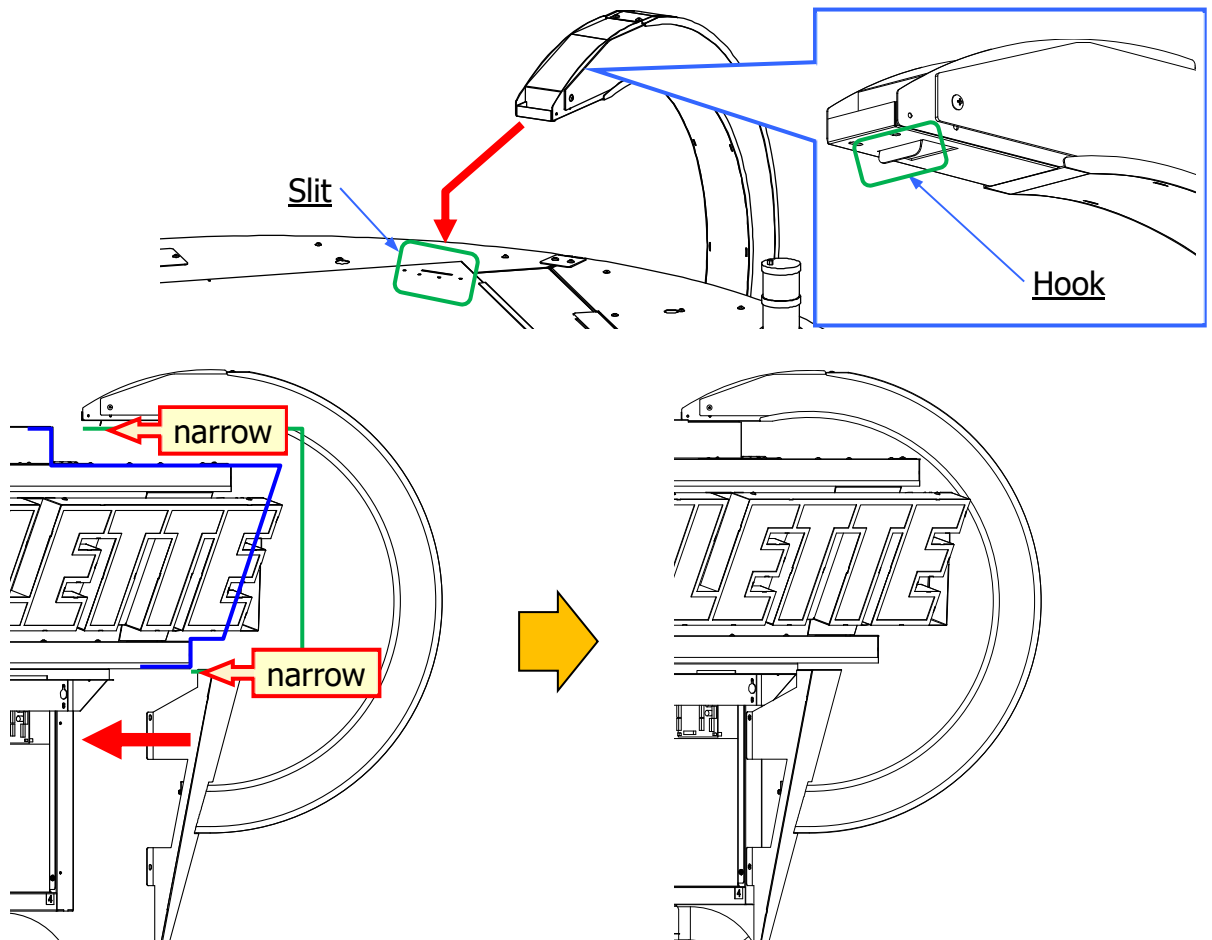

5. Affix the Ring Units to the top and the side of the Top Base Unit by using the 6 screws for each.

Fasteners		Qty	Appearance
F	PAN M4x8 3P	24	

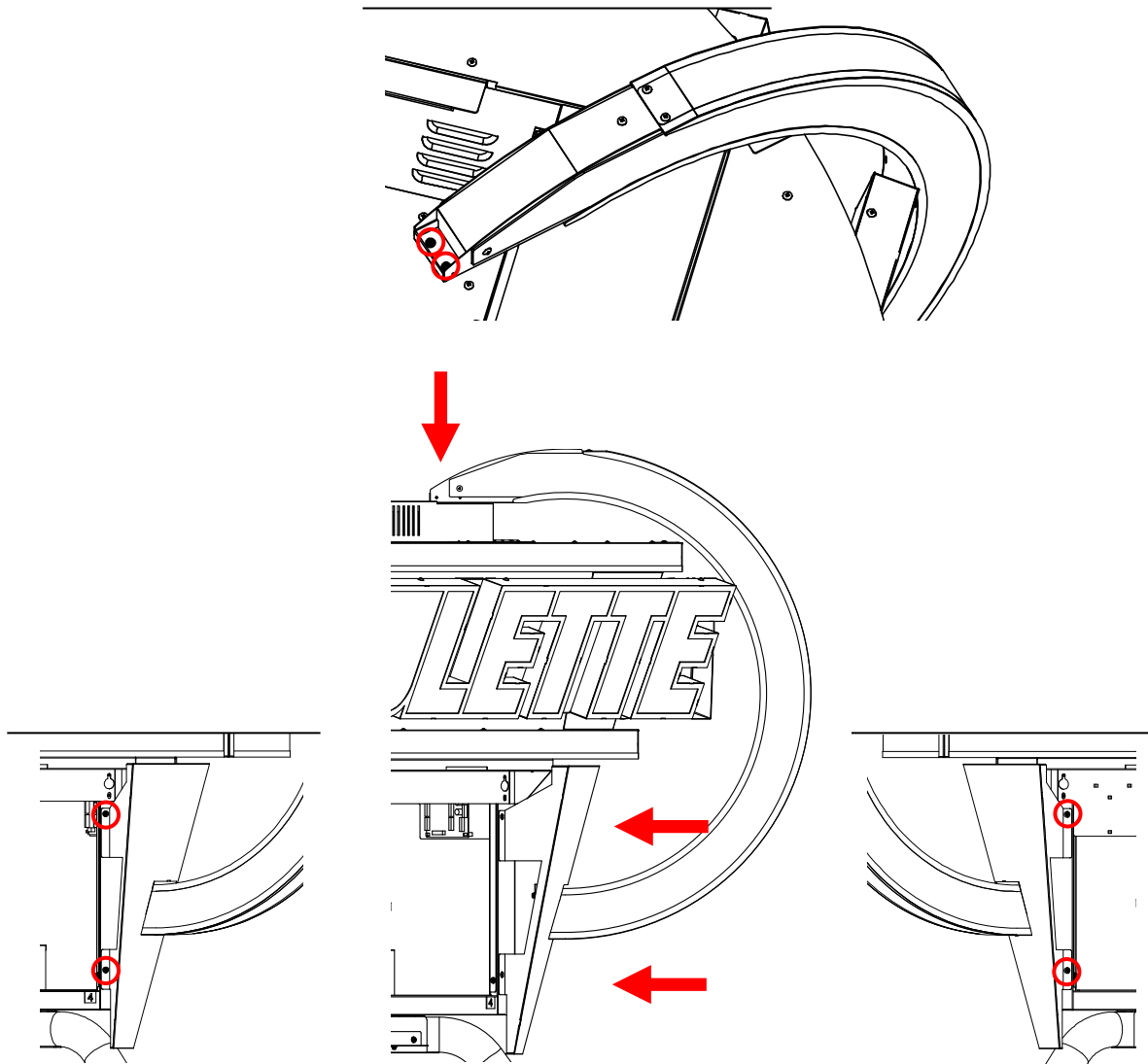

6. Affix the Ring Covers onto the Ring Units by using the 2 screws for each.

Fasteners		Qty	Appearance
Bb	TRUSS M4x10 BLK	8	

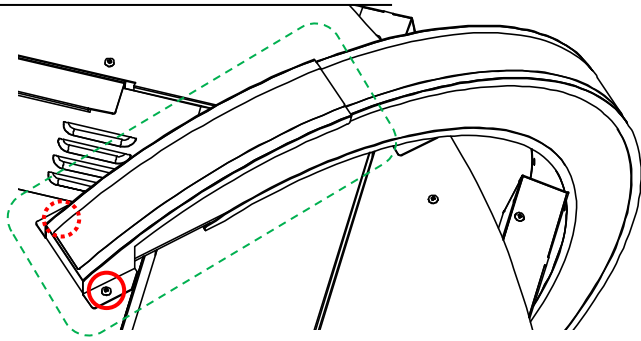

7. Connect the [7W] connectors of the Ring Unit to the [R1L] and [R1R] connectors of the Top Base Unit.

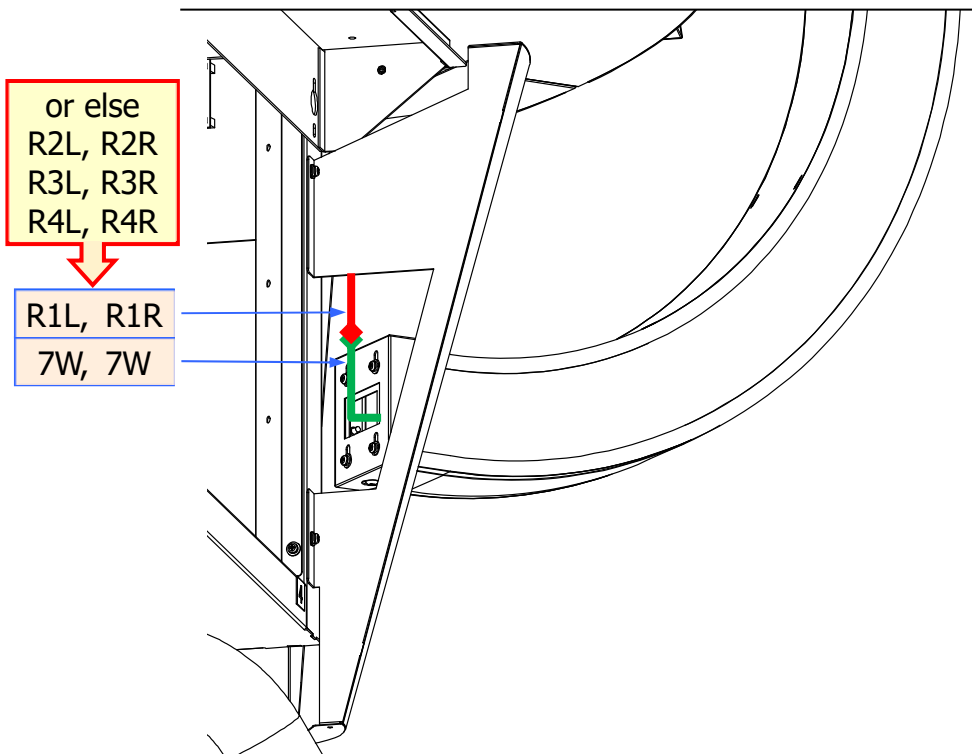

3. 2. 1. 9: Preparing the Monitor Unit

1. Prepare the following Parts.

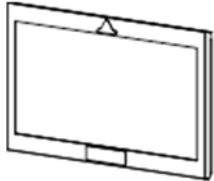
Parts Name	Qty	Appearance
Monitor Assembly • Monitor Unit (32 inch LCD Monitor) • LCD Joint BRKT • Bezel	4	

i NOTE:

The Monitor Assembly is packed with all the parts mentioned above already joint. Therefore, first divide the Assembly into its fundamental parts.

2. Detach the Bezel by removing the 2 screws.

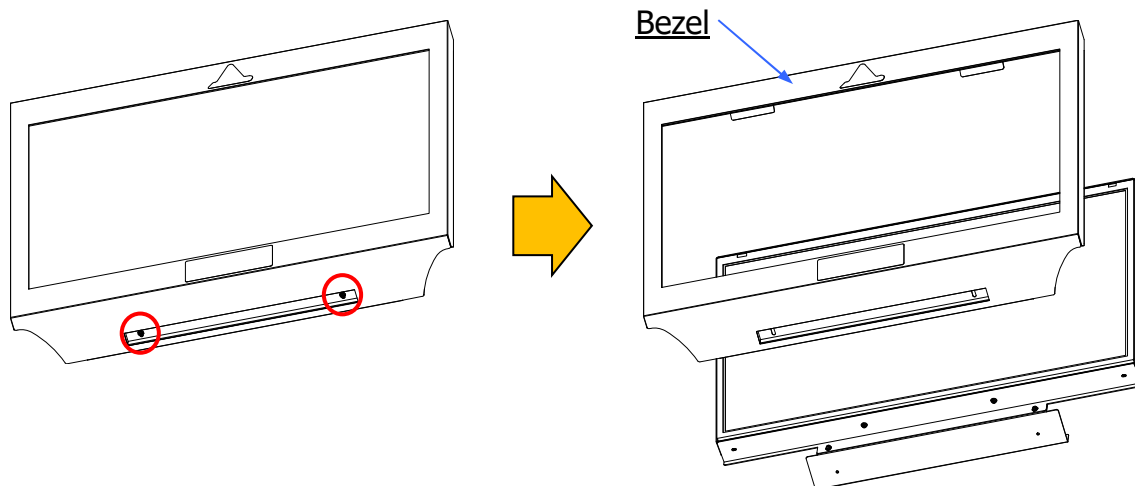

3. Detach the LCD Joint BRKT by removing the 2 screws. The remaining part will be used as Monitor Unit.

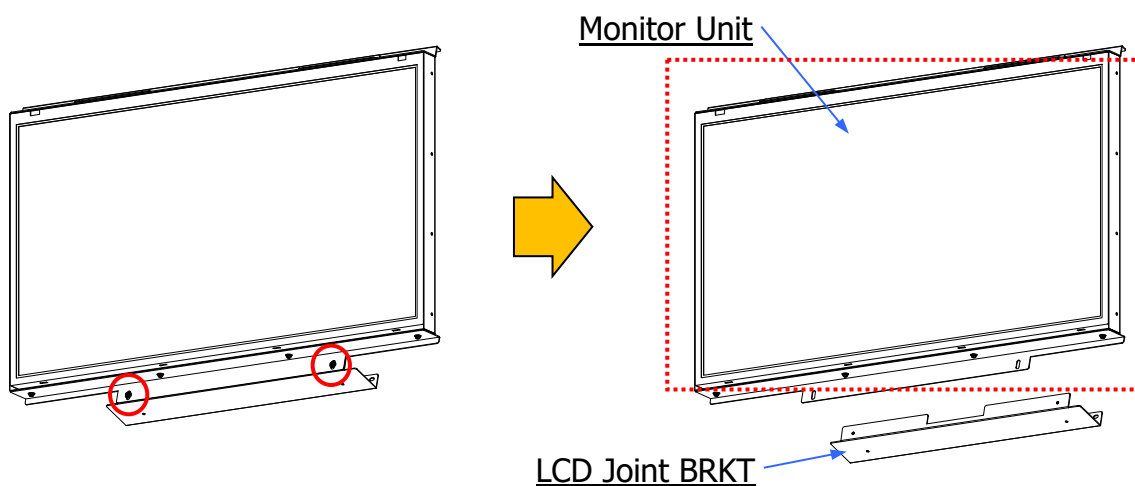

3. 2. 1. 10: Installing the Monitor Unit onto the Top Base Unit

1. Prepare the following Parts.

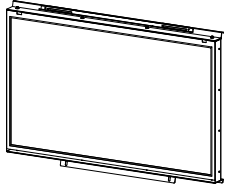
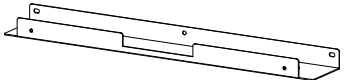
Parts Name	Qty	Appearance
Monitor Unit (Disassembled in 3.2.1.9)	4	
LCD Joint BRKT (Disassembled in 3.2.1.9)	4	

⚠ CAUTION!

Before the installation of the Monitor Unit, make sure that the 2 Switches of the Power Box A and Power Box B, located inside the Top Base Unit, are switched to ON.

Please leave these switches to ON and do not change their status.

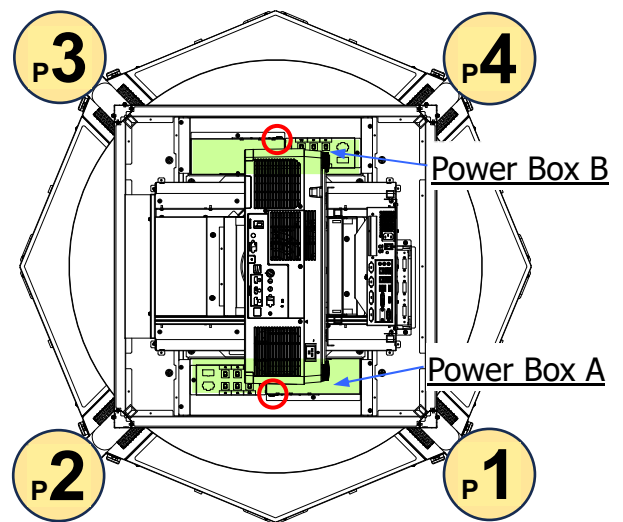
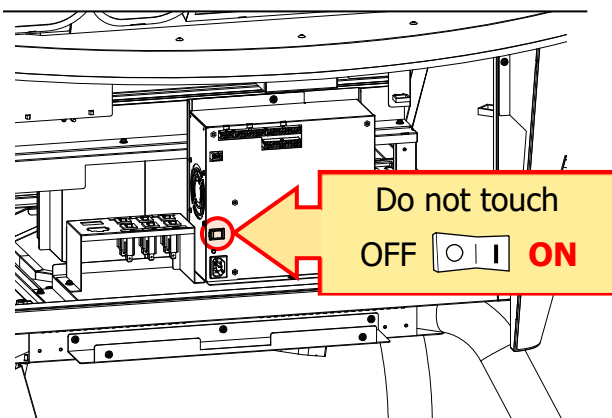

2. Locate the [DVI3] (or [DVI4], [DVI5], [DVI6]), the [LP1] (or [LP2], [LP3], [LP4]) and also the [USB (HSC)] connectors inside the opening of the Top Base Unit.

i NOTE:

The [USB(HSC)] Connector is only on the side of the Power Box A (between Pole 1 and Pole 2). (The connector on the opposite side of the Cable was connected to the Tracking Camera PC at 3.2.1.3.)

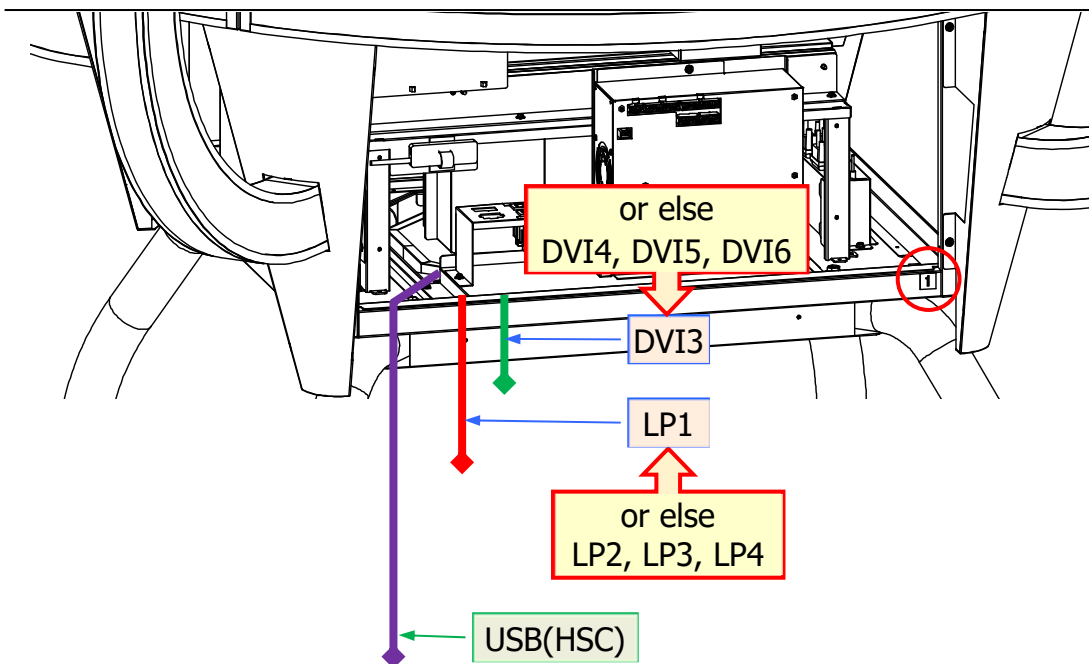
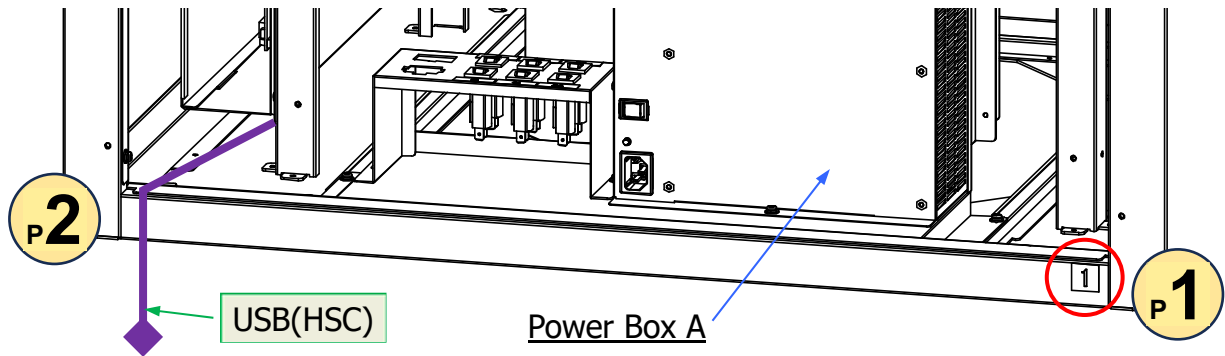

3. Affix the LCD Joint BRKTs on the Top Base Unit by using 3 Screws for each.

Fasteners		Qty	Appearance
F	PAN M4x8 3P	12	

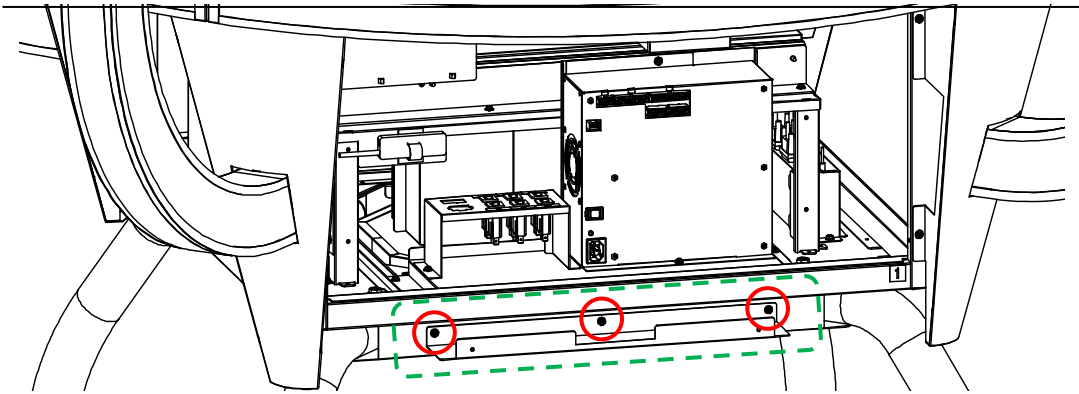

4. Hang the hooks on the back of the Monitor Unit to the slits on the Top Base Unit.

⚠ CAUTION!

- Hold the Monitor Unit with your hands until you are sure that the hooks are firmly hung to the slits.
- Since the operation will be performed in a high place, pay enough attention also to the safety of the surrounding area.

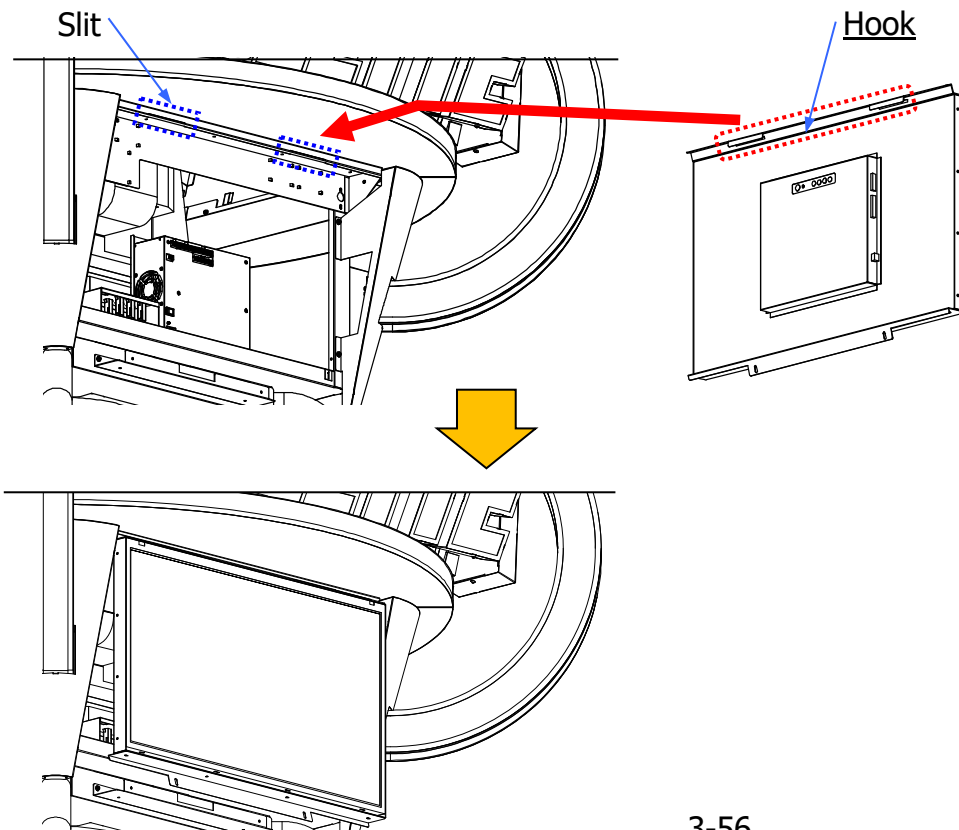

5. Raise the bottom of the Monitor Unit by holding its lower side, and then connect the [DVI3] and [LP1] connectors.

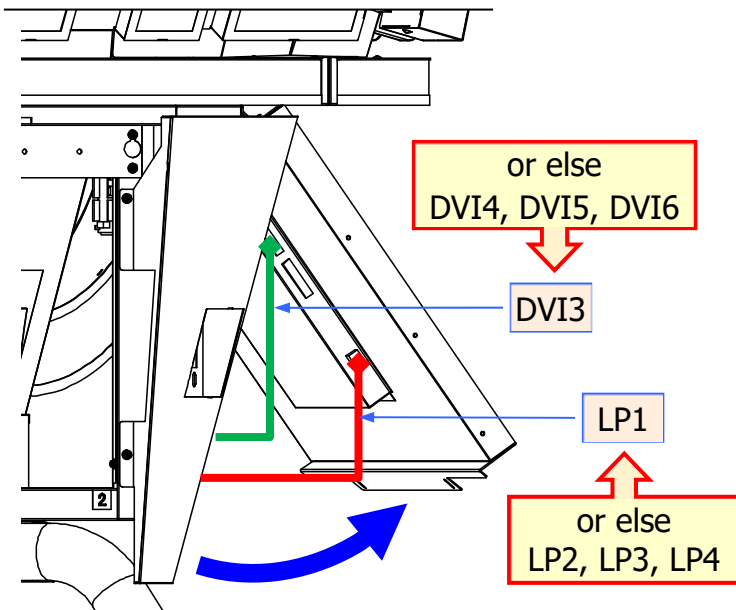

6. Affix the each Monitor Unit to the LCD Joint BRKT by using 2 Screws for each.

Fasteners		Qty	Appearance
F	PAN M4x8 3P	8	

NOTE:

Pull outside the [USB(HSC)] Connector, that was located at STEP 2, through the space between the Monitor Unit and the Top Base Unit.

At this point the machine should look like this.

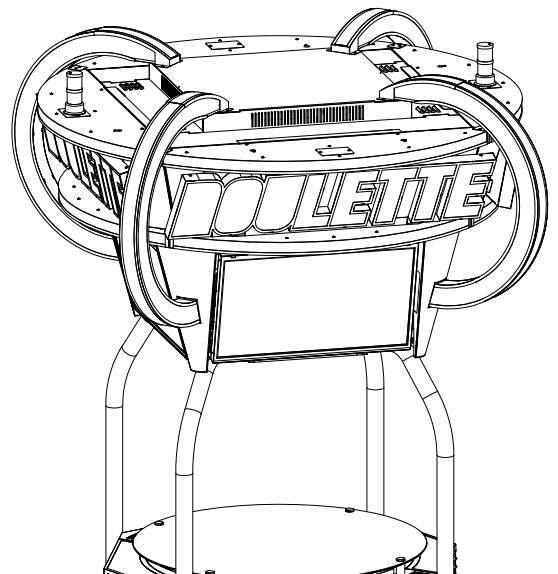
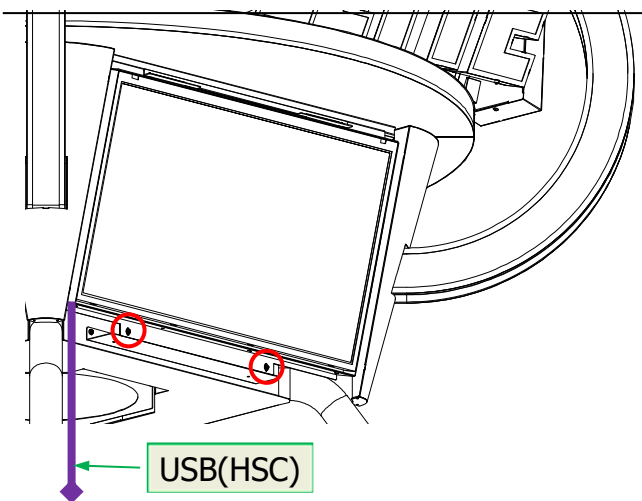

3. 2. 1. 11: Installing the Tracking Camera Unit

- A. Locate the [USB (HSC)] Connector of the Pole 2 and the [I/O] and [LAN] Connectors of the Pole 4 illustrated below.

i NOTE:

If a Connector is hidden in a position impossible to see, refer to the illustration to pull it out.

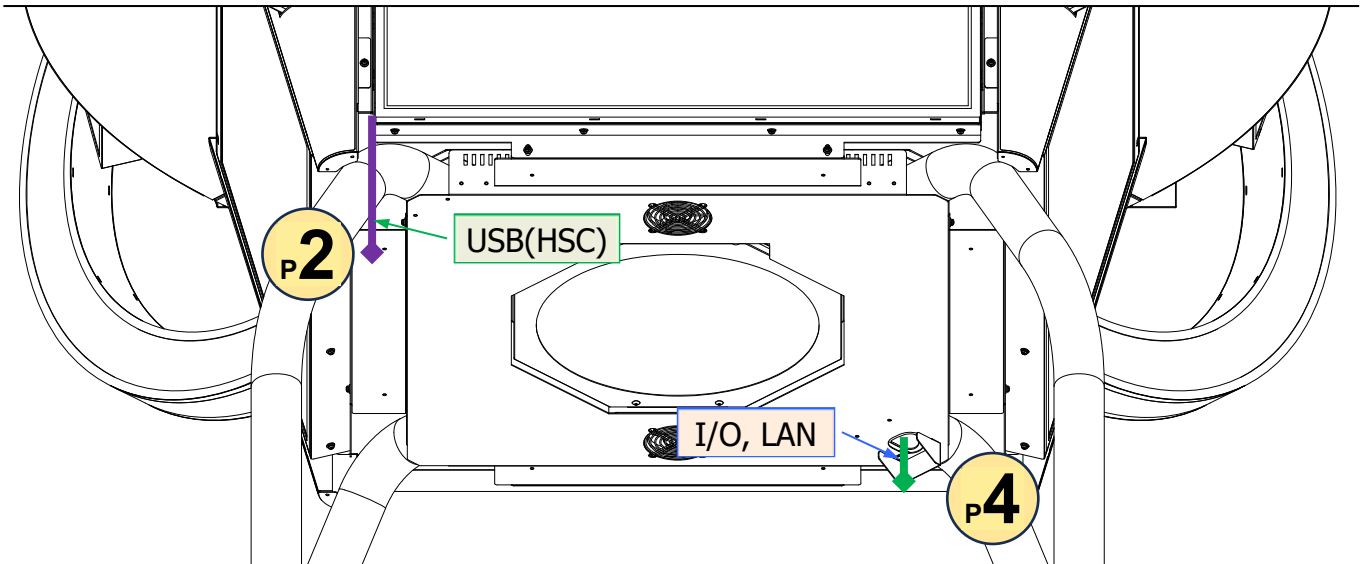

- B. Prepare the following Parts.

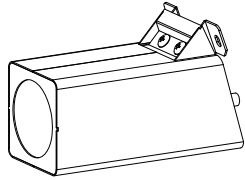
Parts Name	Qty	Appearance
Tracking Camera Unit	1	

- C. Remove 2 screws to detach the Tracking Camera Cover.

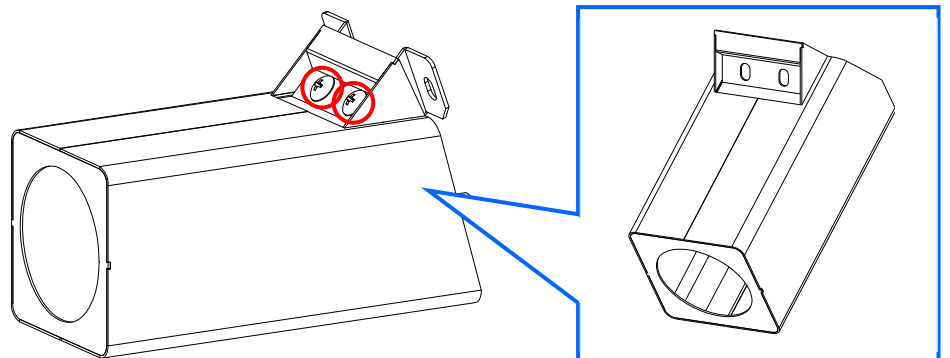

- D. Connect the [USB(HSC)] Connector of Pole 2 to the Tracking Camera Unit, then affix the Tracking Camera Unit to the Center Unit by using 2 screws.

Fasteners		Qty	Appearance
Bb	TRUSS M4x10 BLK	2	

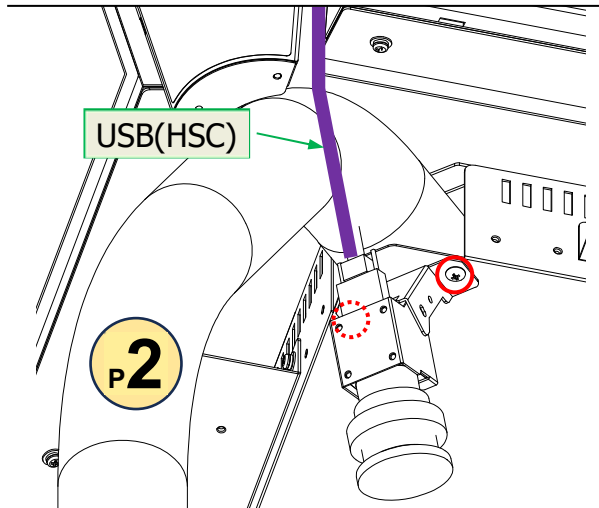

3. 2. 1. 12: Installing the Live Camera Unit

[For HBVCAM-F2028HD-V11]

A. Prepare the following Parts.

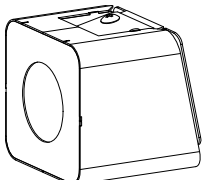
Parts Name	Qty	Appearance
Live Camera Unit (HBVCAM-F2028HD-V11)	1	

B. Remove 2 screws to detach the Live Camera Cover.

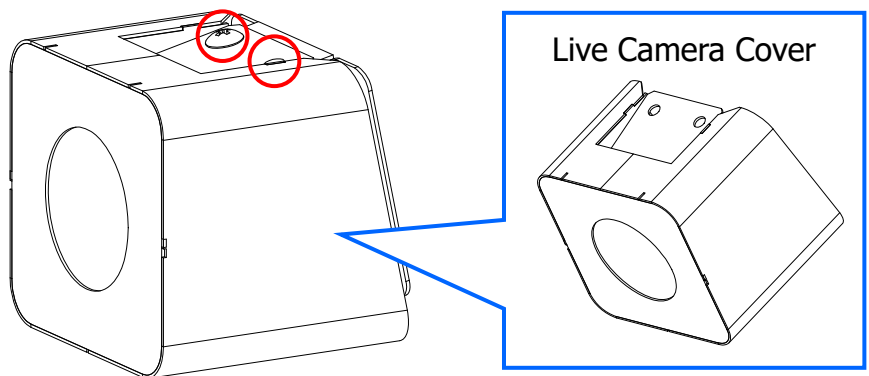

C. Connect the [CM] Connector of Pole 4 to the Live Camera Unit, then affix the Live Camera Unit to the Center Unit by using 2 screws.

Fasteners	Qty	Appearance
Bb TRUSS M4x10 BLK	2	

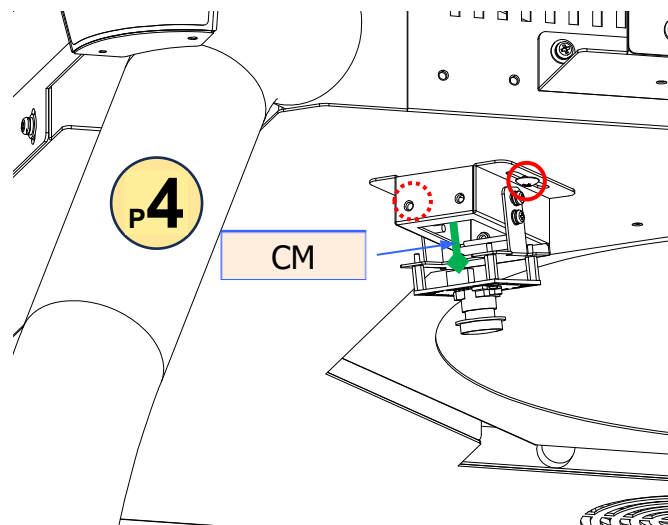

[For HD-NDI-200]

A. Prepare the following Parts.

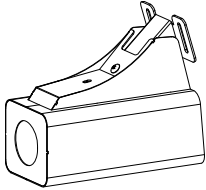
Parts Name	Qty	Appearance
Live Camera Unit (HD-NDI-200)	1	

B. Remove 2 screws to detach the Live Camera Cover.

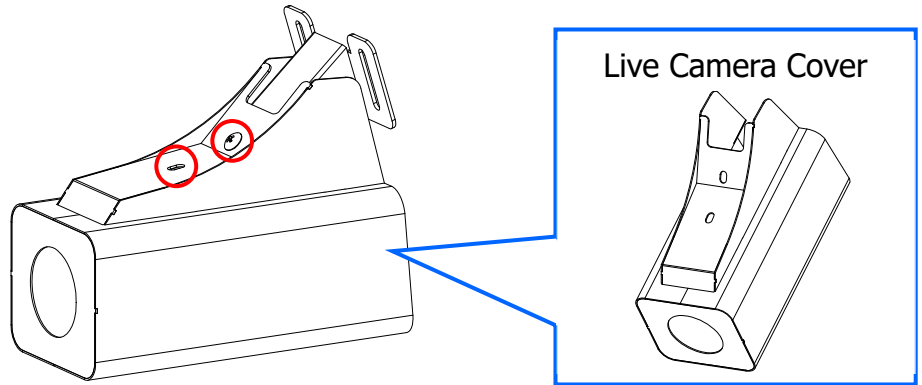

C. Connect the [I/O] and [LAN] Connectors of Pole 4 to the Live Camera Unit, then affix the Live Camera Unit to the Center Unit by using 2 screws.

Fasteners	Qty	Appearance
Bb TRUSS M4x10 BLK	2	

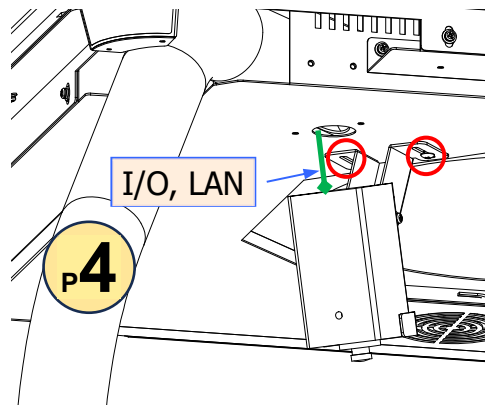

3. 2. 1. 13: Installing the Joint BRKT

1. Prepare the following Parts.

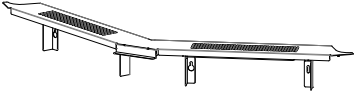
Parts Name	Qty	Appearance
Joint BRKT A Unit	4	

2. Affix the Joint BRKT A Units to the Center Unit by using 4 screws on each.

Fasteners	Qty	Appearance
F PAN M4x8 3P	8	

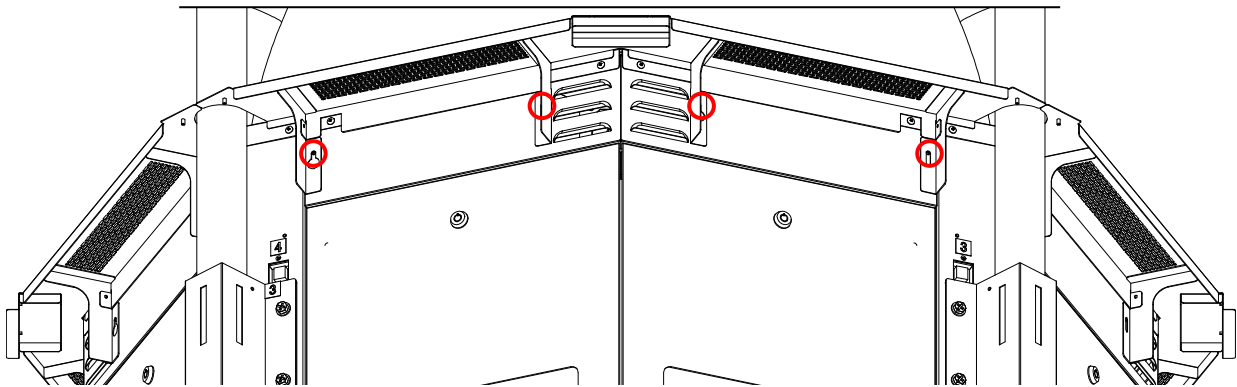

3. Prepare the following Parts.

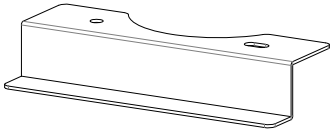
Parts Name		Qty	Appearance
Joint BRKT B		4	

4. Affix the Joint BRKT B to the Joint BRKT A Unit by using 2 Nuts on each.

Fasteners		Qty	Appearance
R	FLANGE NUT M4	8	

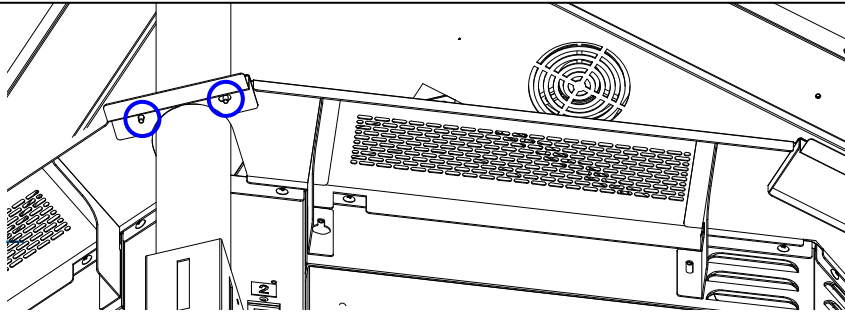

At this point the machine should look like this.

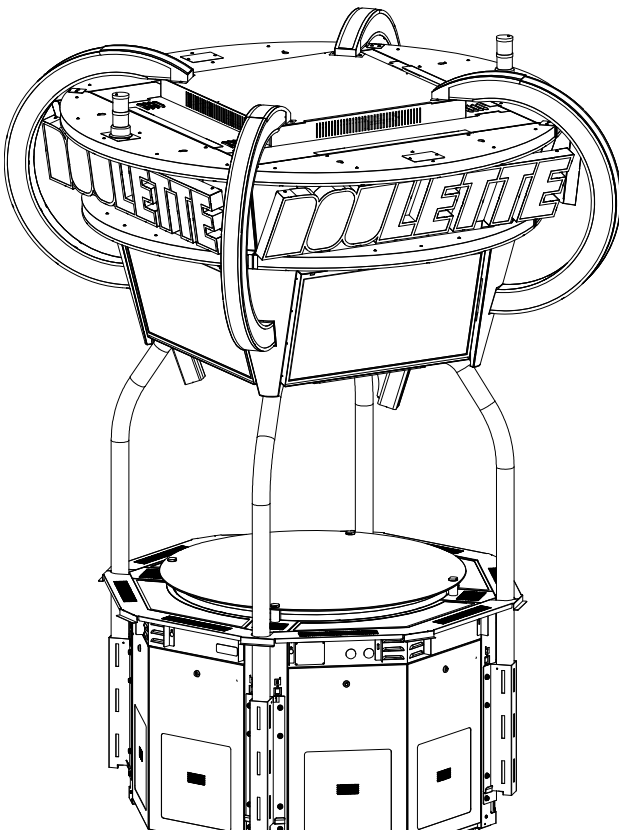

3. 2. 1. 14: Connecting the Top Base Unit to the Center Unit

1. Unlock and remove the Center Unit Doors. Untie the cables tied near each Corner of the Cabinet.

i NOTE:

Remove first the door on the right side, and then the one on the left side.

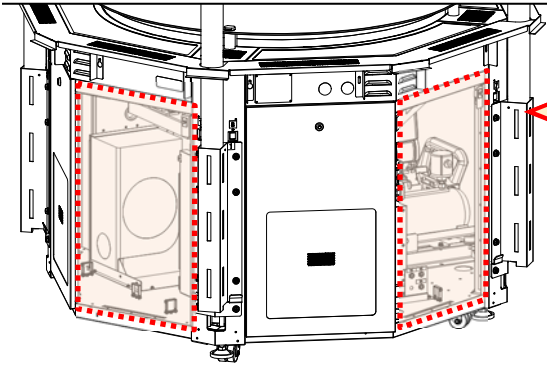

The Right Side Door is first.

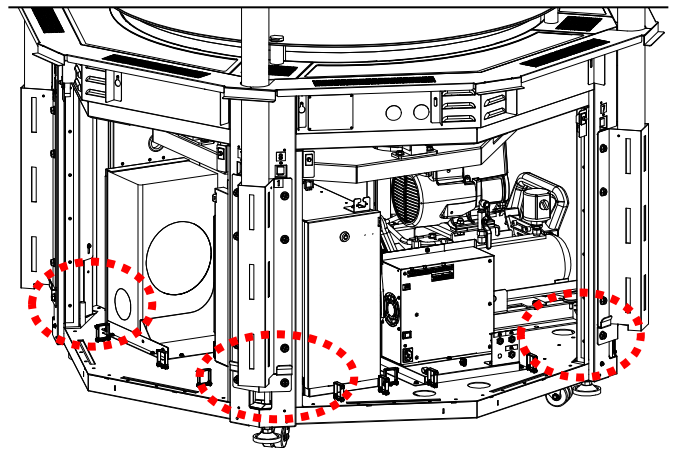

s1 = Station **p1** = Pole **c1** = Corner

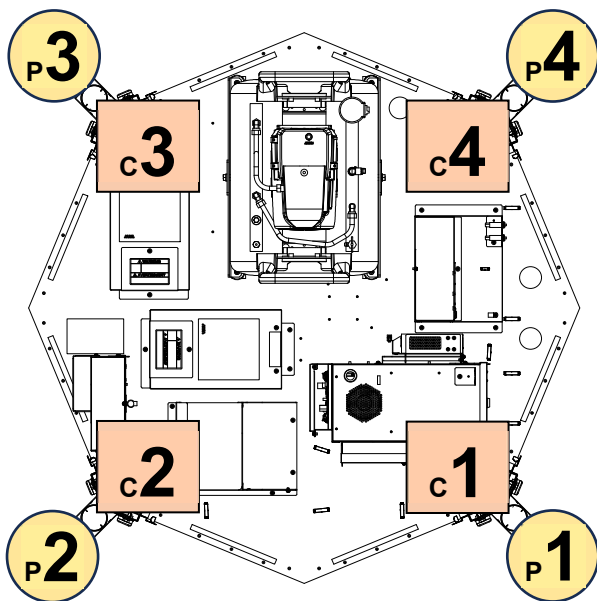

- Connect the [TL], [DVIC] and [F56] Connectors from Pole 1 to the [TL], [DVIC] [F56] Connectors of the Center Unit

Corner No.	Connectors from Poles	Connectors of Center Unit
1	[TL], [DVIC], [F56]	[TL], [DVIC], [F56]
2		
3		
4		

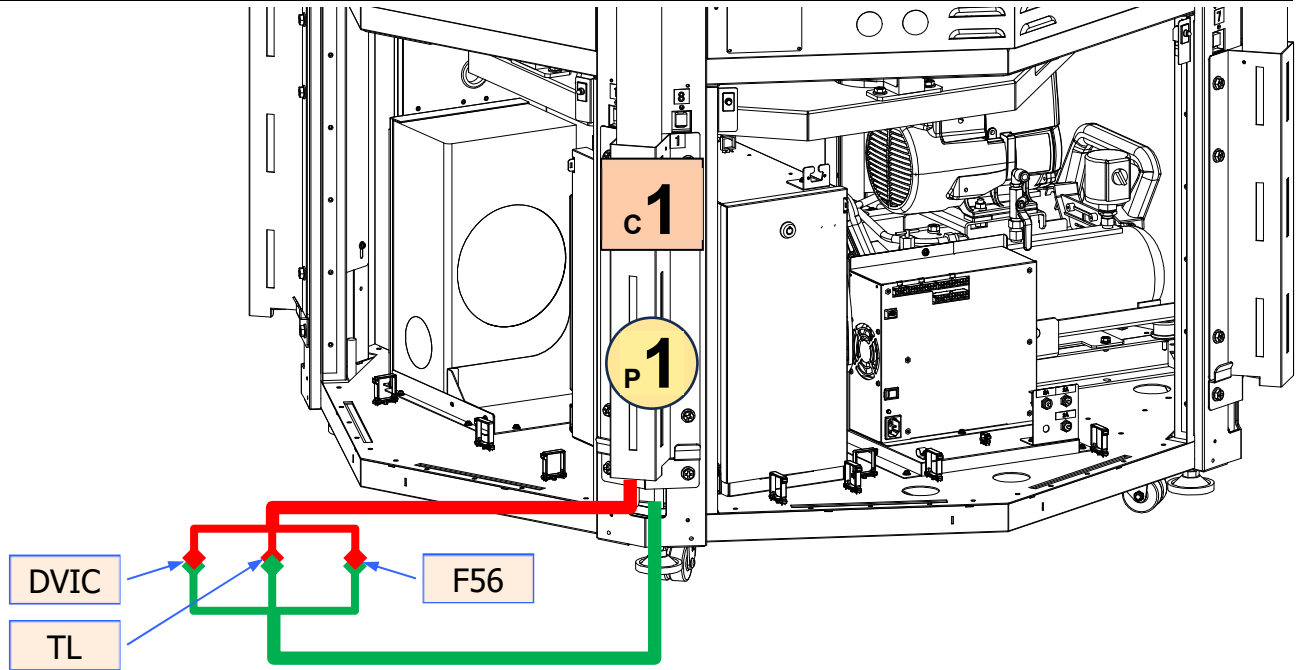

3. Connect the [USB4(A)] and [USB5(B)] Connectors from Pole 2 to the [USB4(A)] and [USB5(B)] Connectors of the Center Unit

Corner No.	Connectors from Poles	Connectors of Center Unit
1		
2	[USB4(A)], [USB5(B)]	[USB4(A)], [USB5(B)]
3		
4		

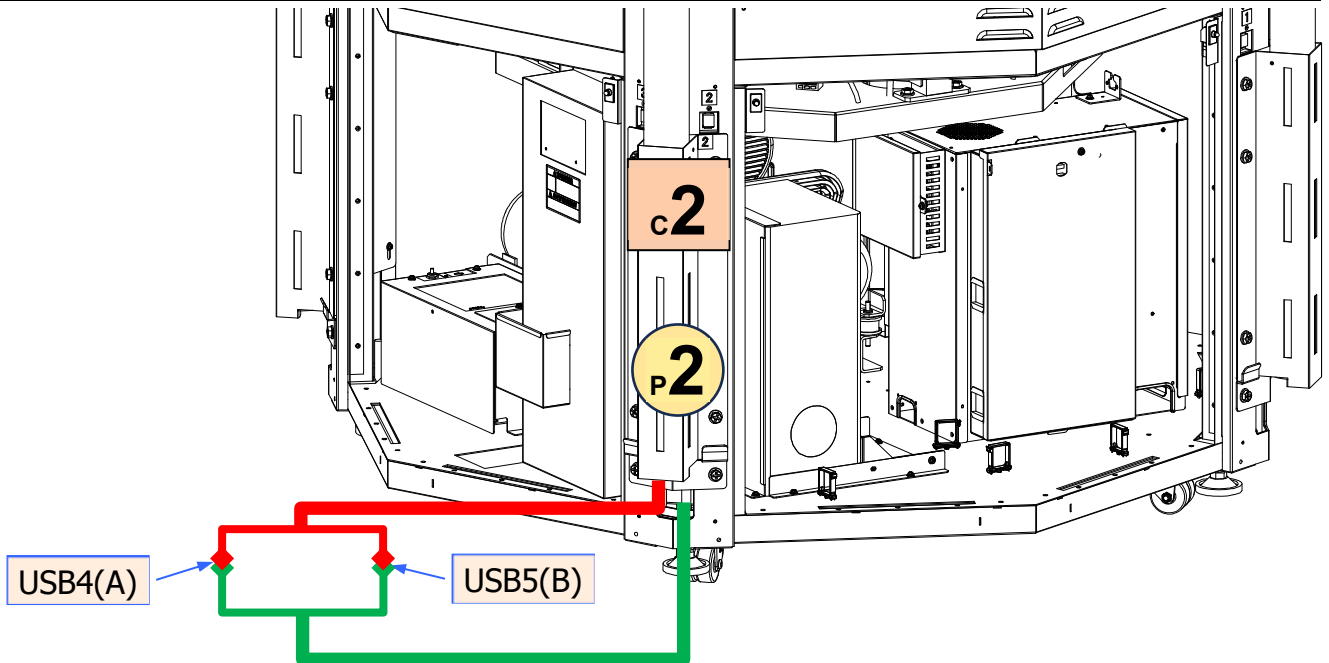

4. Connect the 2 [IN] Cables from Pole 3 to the [AC2] and [AC3] Cables of the Center Unit

Corner No.	Connectors from Poles	Connectors of Center Unit
1		
2		
3	[IN] x2	[AC2], [AC3]
4		

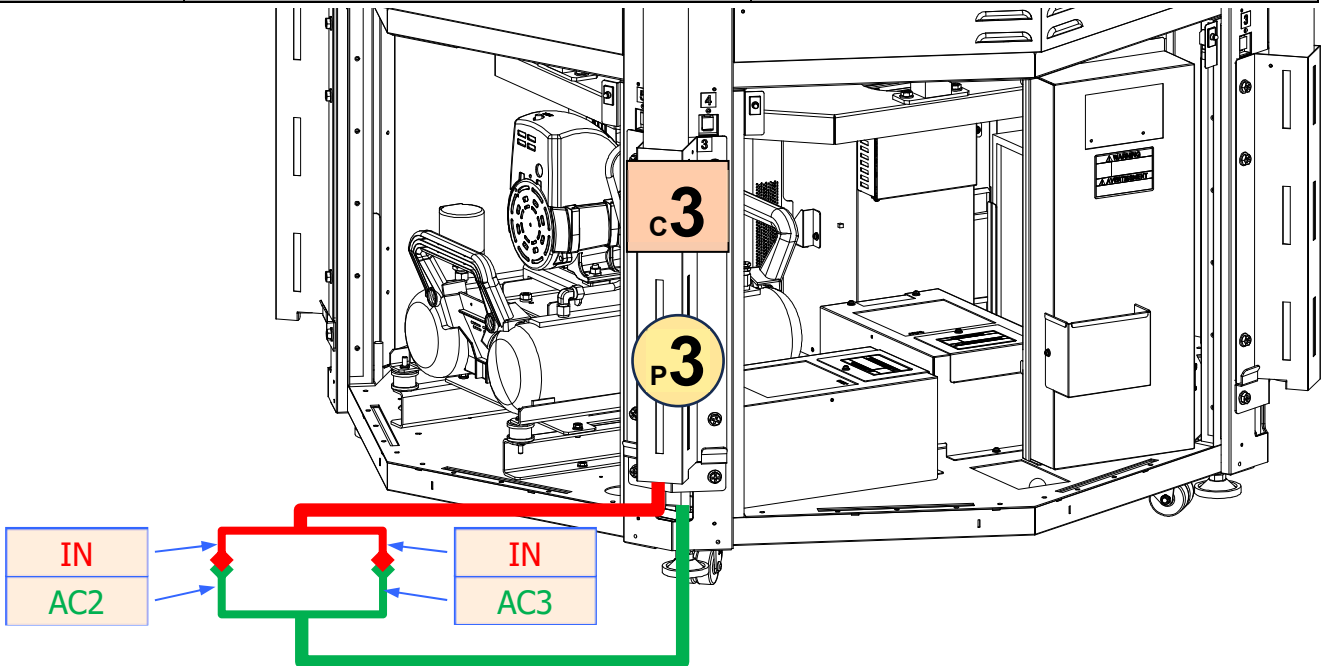

- Connect the [DVI2], [USB2], [CM3] Connectors from Pole 4 to the [DVI2], [USB2], [CM3] Connectors of the Center Unit.

Corner No.	Connectors from Poles	Connectors of Center Unit
1		
2		
3		
4	[DVI2], [USB2], [CM3]	[DVI2], [USB2], [CM3]

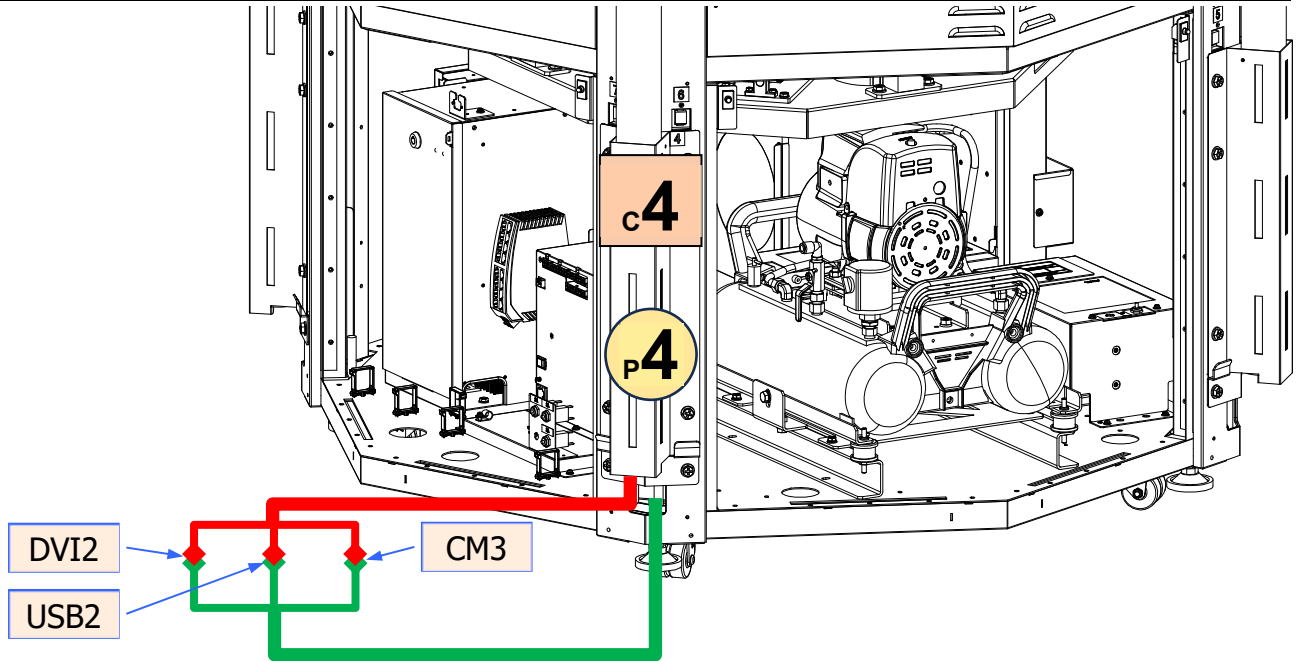

6. Pull the [LAN(LB)] Connector from the Pole 4 into the Center Unit, and connect it to the Switching HUB, following the route indicated by the illustration.

Corner No.	Connectors from Poles	Connectors of Center Unit
1		
2		
3		
4	[LAN(LB)]	Switching HUB

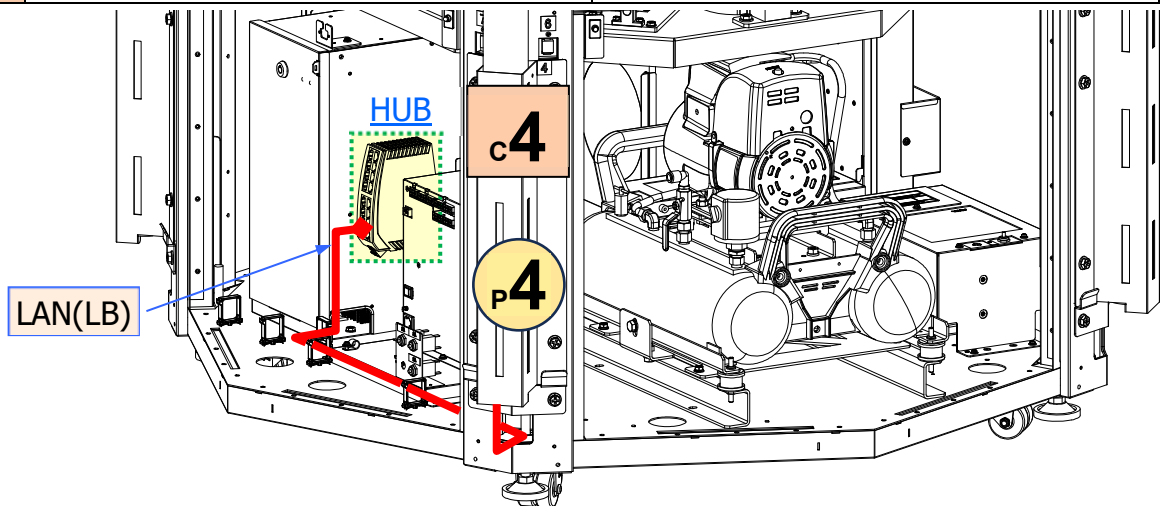

i NOTE: Option-[In case it is planned to extend the number of stations]

Refer to Chapter 3.2 [Limitation for extension] to connect in advance the [LAN] Cable for the Extension stations to the Switching HUB. Then pull the [LAN] Cable from the Center Unit and arrange it so that it will not get in the way of the installation procedures

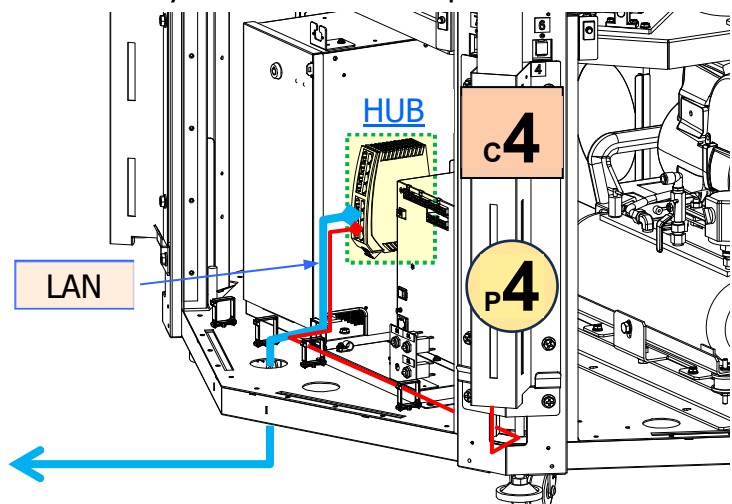

7. The connectors of the Top Base Unit are now connected to the Center Unit. Arrange the cables installed so that they will not be an obstacle to the further procedures.

3. 2. 1. 15: Hardware Setting for Center Unit

Hardware Settings are necessary for factory shipped products to be operational. Before commencing with operation, make sure to do the settings explained below.



WARNING!

Electrostatic discharge may damage internal components. When accessing the inside of the Cabinet, take anti-static measures (as wearing anti-static wrist band etc.) before proceeding.



CAUTION!

Hardware Settings must be done by authorized personnel.

- Location of PCBs -

The PCBs that require setting are shown inside a box below.

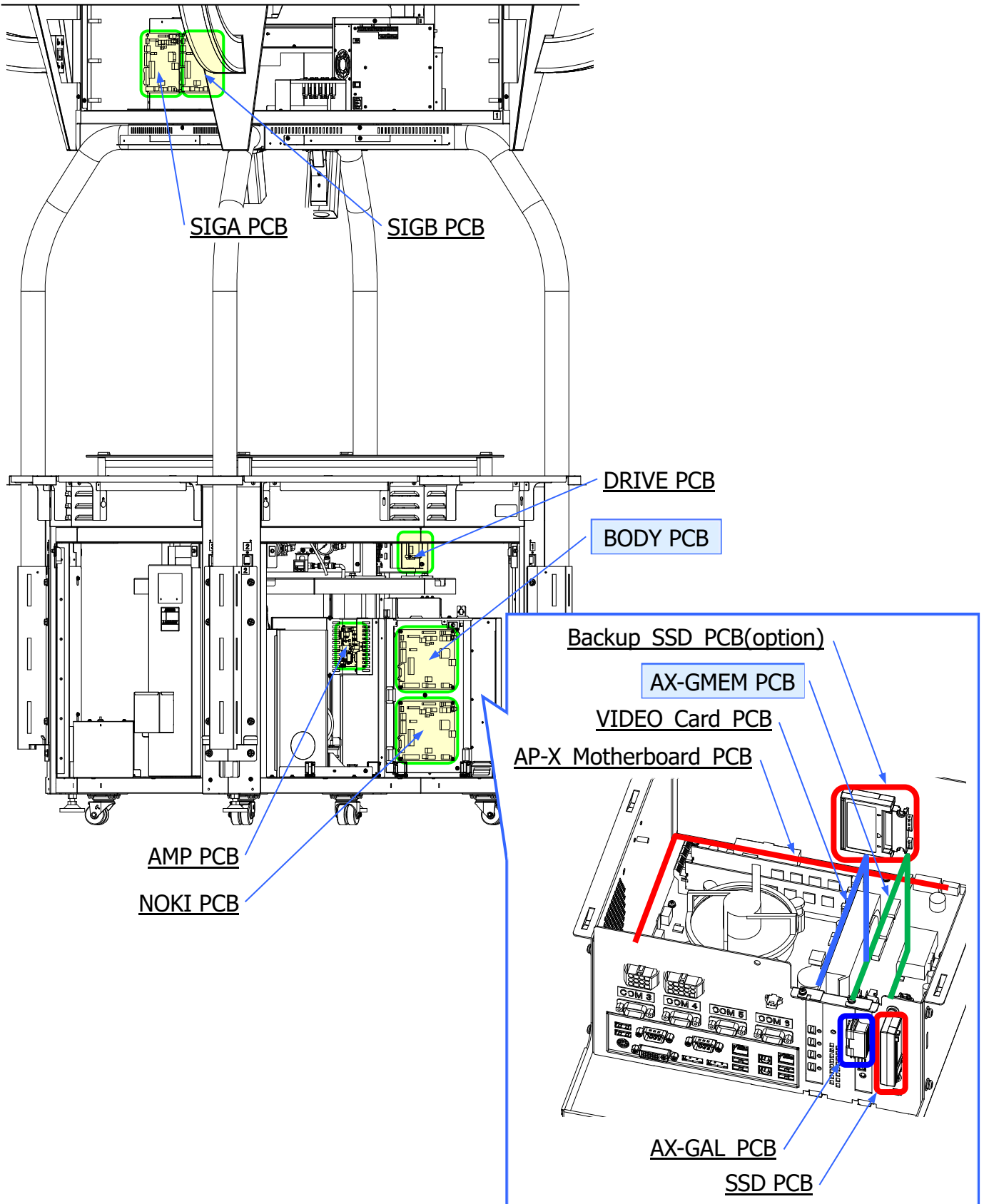

- AX-GMEM PCB -

PCB	Onboard Switch/Jumper	Factory Setting	Setting for Operation	Description
AX-GMEM PCB	S2 (Slide Switch)	Front (Battery OFF)	Back (Battery ON)	The switch for Backup Battery ON-OFF

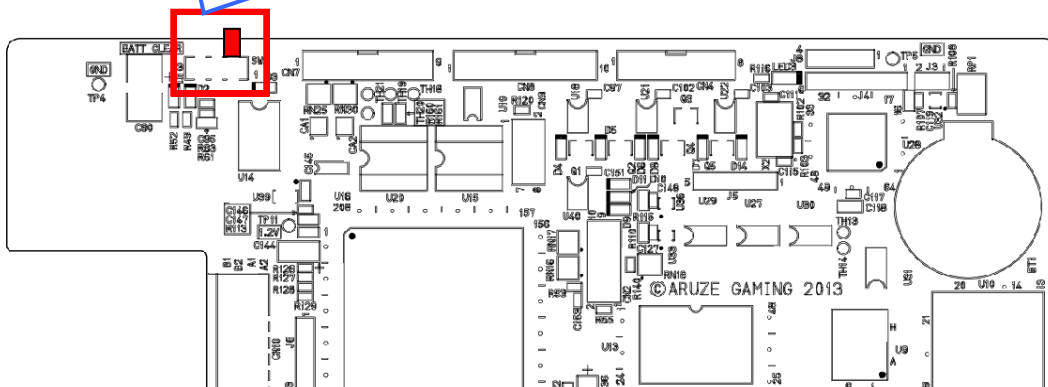
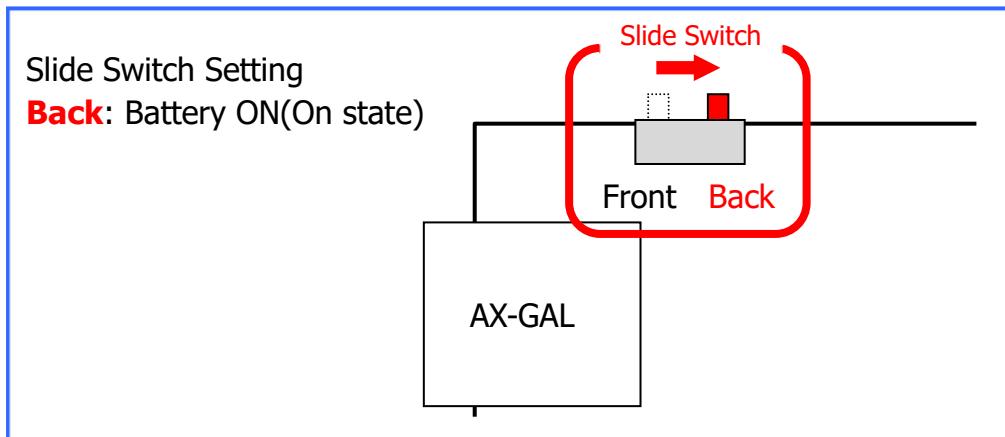
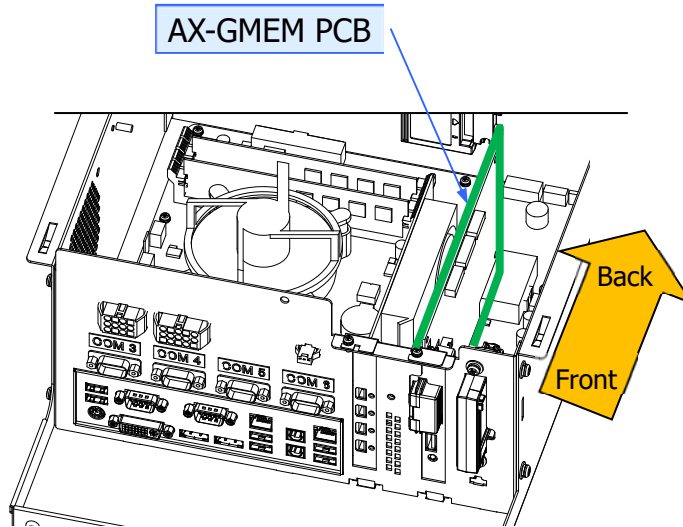

- BODY PCB -

PCB	Onboard Switch/Jumper	Factory Setting	Setting for Operation	Description
BODY PCB	SW2(2 Bit Dip Switch)	All OFF (Invalid)	All ON	The switch for enabling the Backup Battery

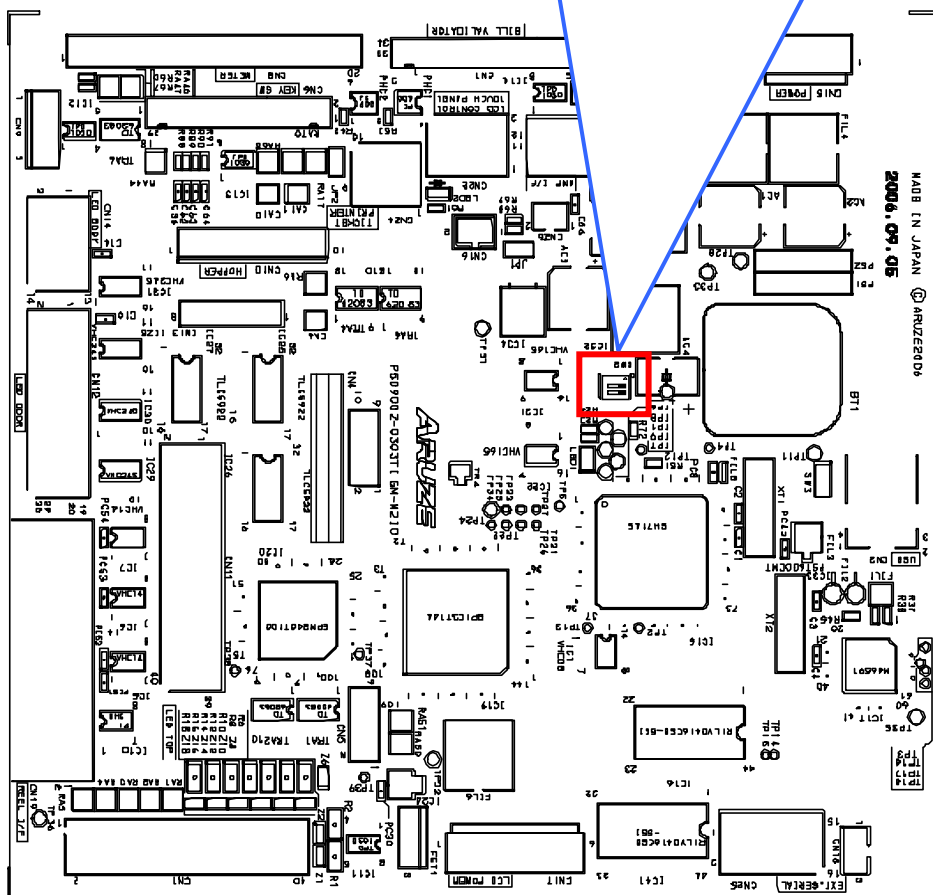
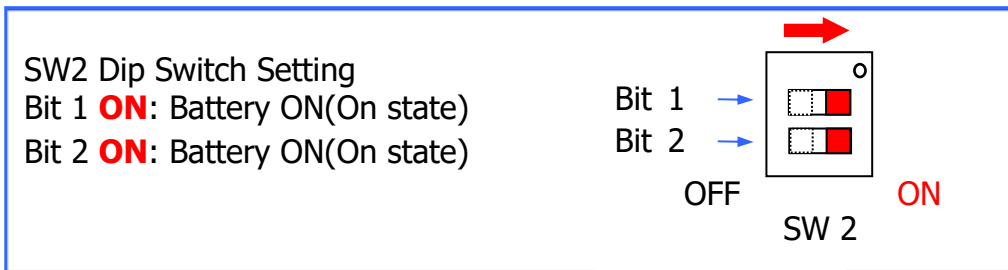
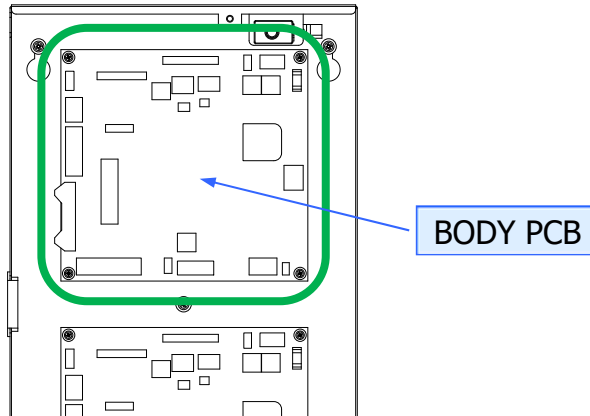

3. 2. 1. 16: Connecting the Center Unit to the Power Source

1. Remove one screw to the Switch Board Unit to detach the Switch Board Cover, and locate the Terminal Block.

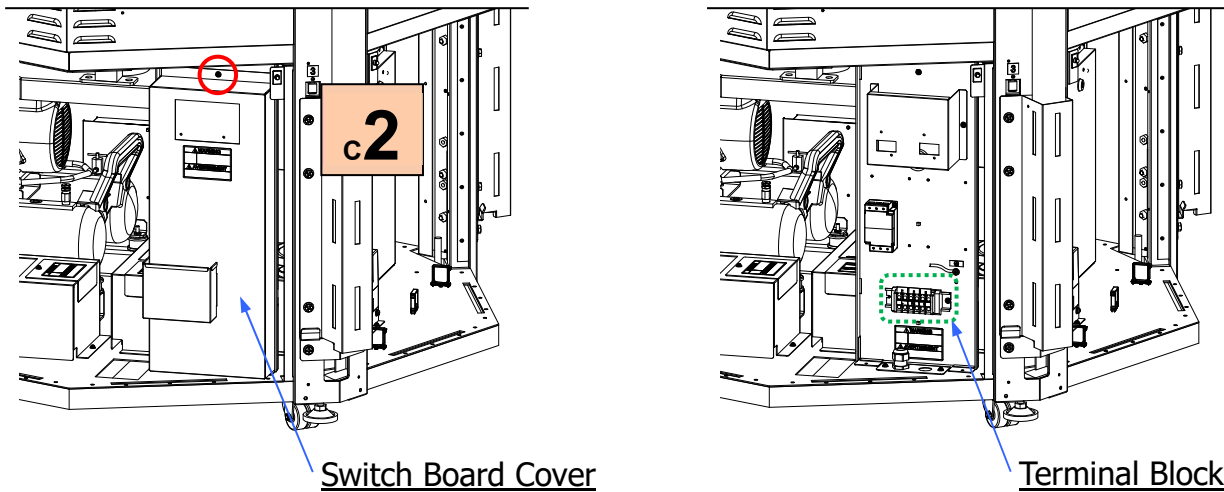

2. Insert your prepared 3Core, 2.0Sq Cabtyre Power Cable inside the Center unit, from the bottom. Then secure the power cable by turning the bush and install a 4mm diameter Solderless Terminal conforming to the Power Cable.

⚠ DANGER!

Risk of Electric Shock.

- The procedure for the connection to the Terminal Block can be performed only by electrical contractors or by qualified electricians.
- Before connecting power line, make sure to check that the power is OFF.

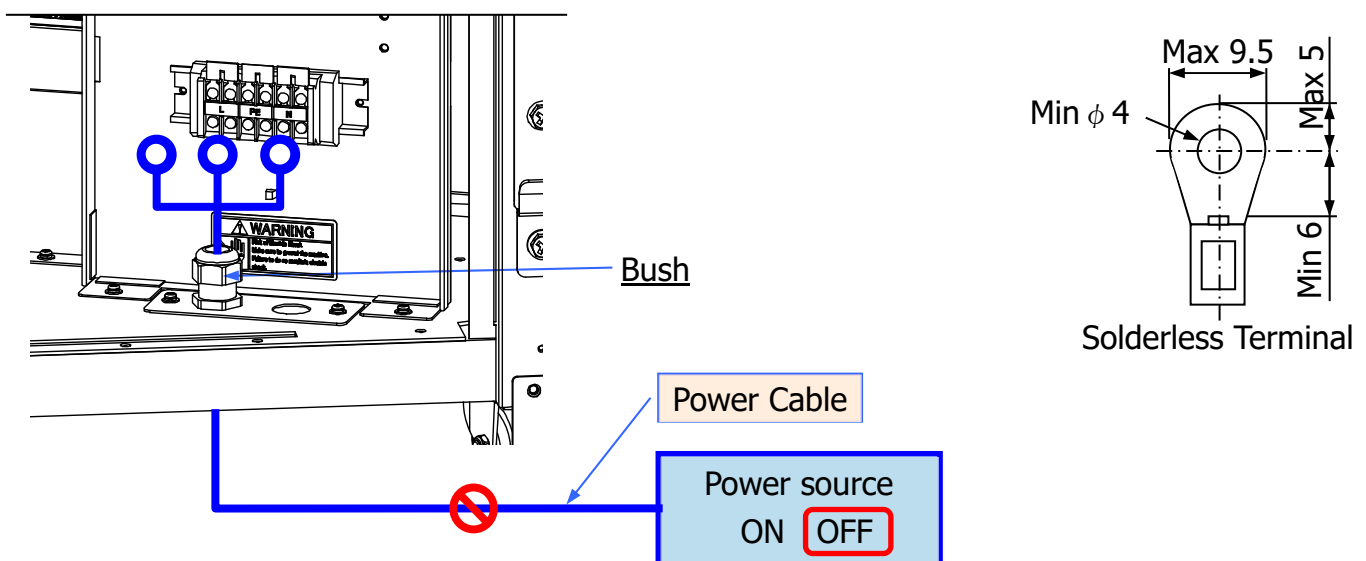

3. Connect the Cabtyre Power Cable to the terminal block.

Description of terminal notation
L : Live
PE : Protective Earth
N : Neutral

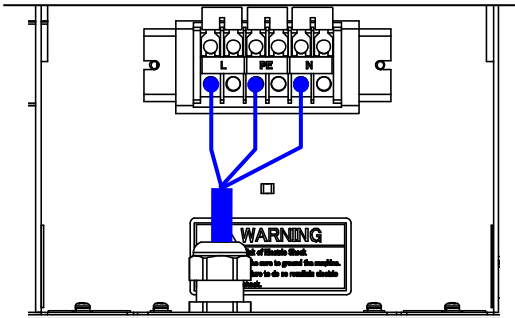

4. Return the Switch Board Cover.
 5. Plug the 2 AC Plugs from Pole 3, one for the Projector and the other for the Tracking Camera PC, to a power receptacle previously prepared.

⚠ CAUTION!

The Power Switches of the Projector and of the Tracking Camera PC are fixed to ON.

Do not electrify the Power Receptacle.

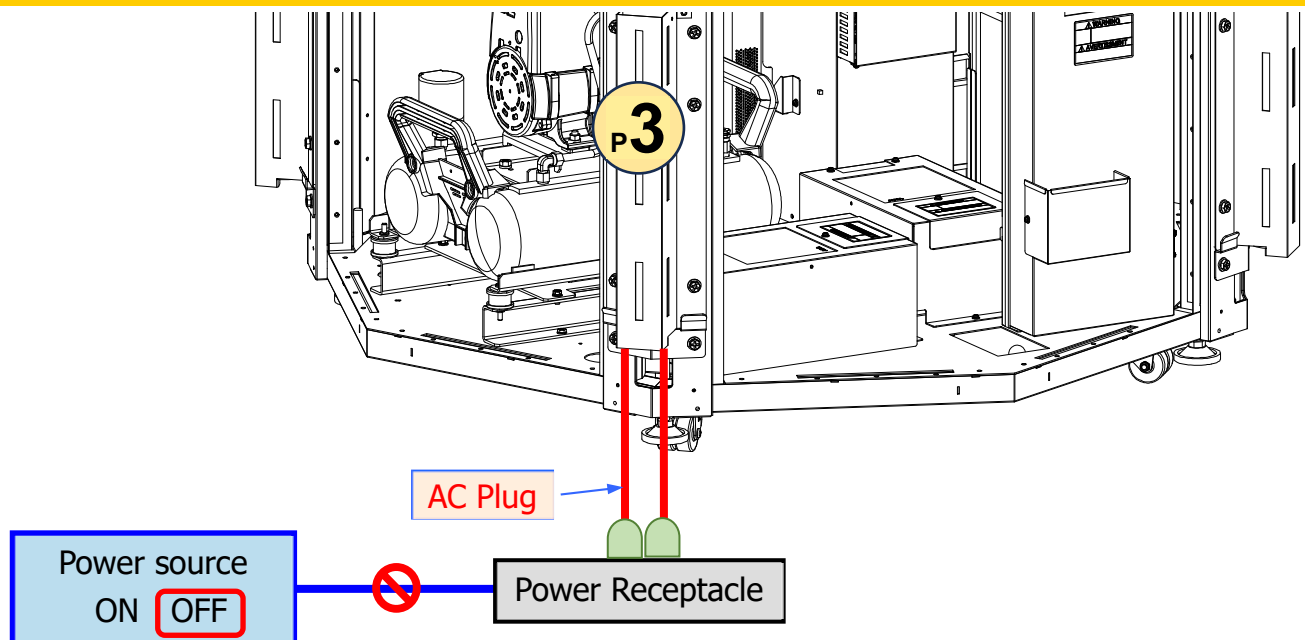

6. Arrange the cables so that they will not get in the way during the installation procedure.

3. 2. 1. 17: Preparation to install the Stations

1. Prepare the following Parts.

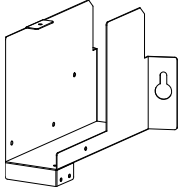
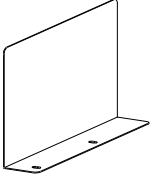
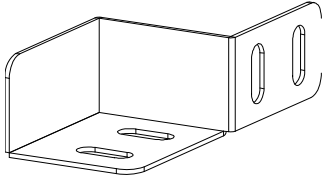
Parts Name	Qty	Appearance
Harness BRKT A	2	
Separate BRKT A	2	
Joint BRKT C	2	

2. Affix the Separate BRKT A and the Joint BRKT C to the Harness BRKT A by using 2 screws on each.

Fasteners		Qty	Appearance
F	PAN M4x8 3P	8	

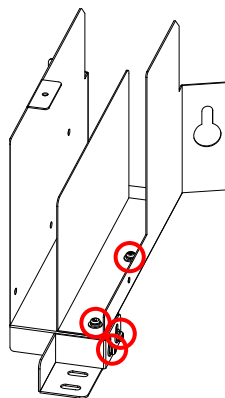

3. Affix the Harness BRKT Units assembled above, to the feet of Corner 2 and Corner 4 on the Center Unit, by using 2 screws on each.

Fasteners		Qty	Appearance
F	PAN M4x8 3P	4	

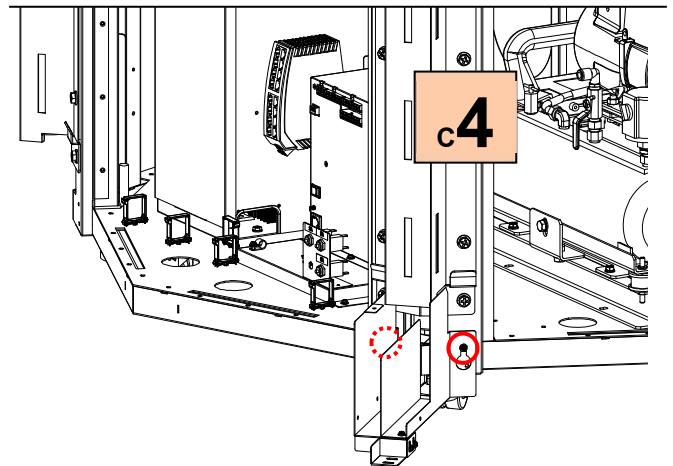
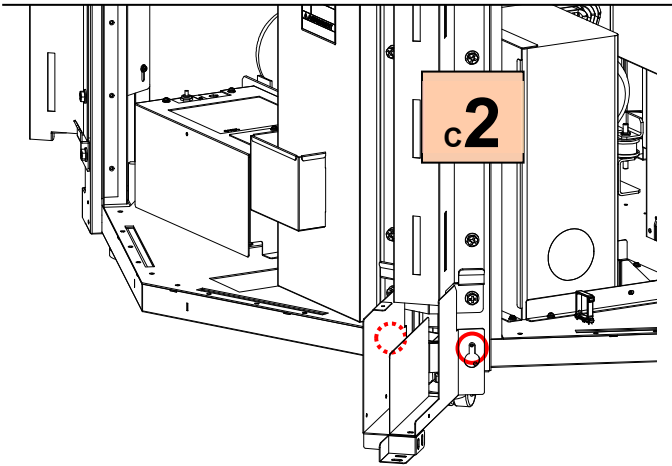

3. 2. 1. 18: Attaching the Control Spacer Unit and the Drain Spacer Unit

1. Prepare the following Parts.

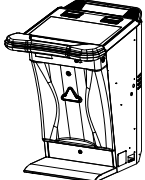
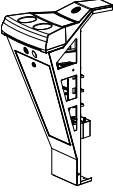
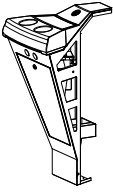
Parts Name	Qty	Appearance
Stations (STATION No.03 and No.07)	2	
Control Spacer Unit [RIGHT FILLER OF STATION No.03] (for Power Switch)	1	
Drain Spacer Unit [RIGHT FILLER OF STATION No.07] (For Air Filter)	1	

2. Unlock and remove the Front Door of each station.

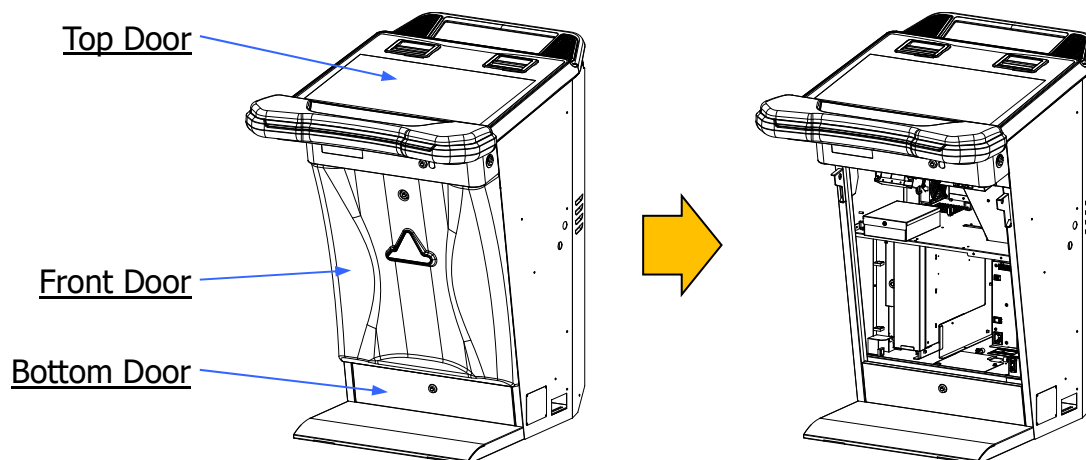

3. Affix the [RIGHT FILLER OF STATION No.03] to the right side of the [STATION No.03] by using 4 screws. This Station will become [Station 3 Unit].

Fasteners		Qty	Appearance
F	PAN M4x8 3P	4	

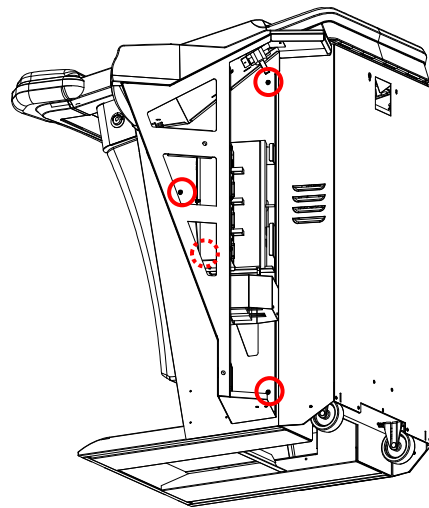
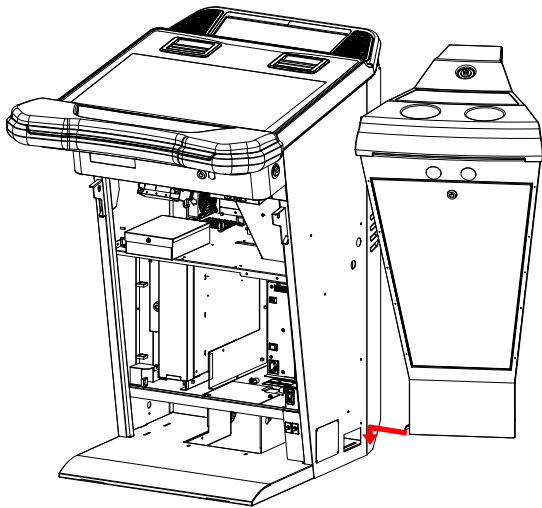

4. Affix the [RIGHT FILLER OF STATION No.07] to the right side of the [STATION No.07] by using 4 screws. This Station will become [Station 7 Unit].

Fasteners		Qty	Appearance
F	PAN M4x8 3P	4	

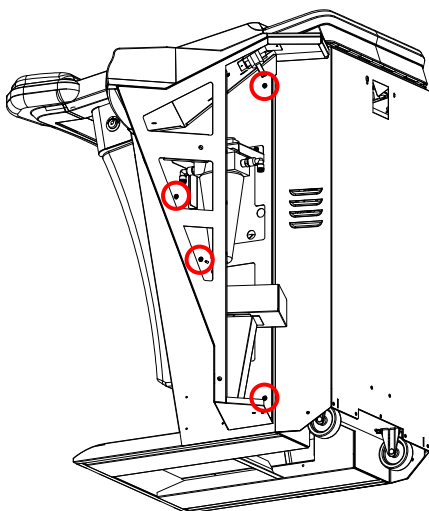
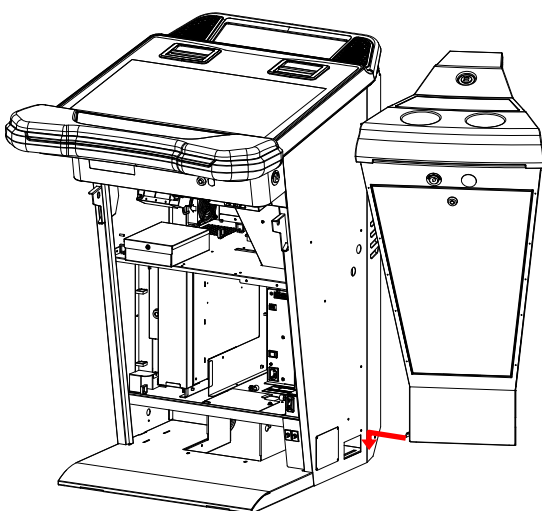

5. Unplug the [BL] connector connected to the inside of the station. Push inside the Station the [BLR] and [OPW] connectors located inside each Spacer Unit, through the opening on the lateral side, and connect them to the [BL] and [OPW] connectors of the Station.

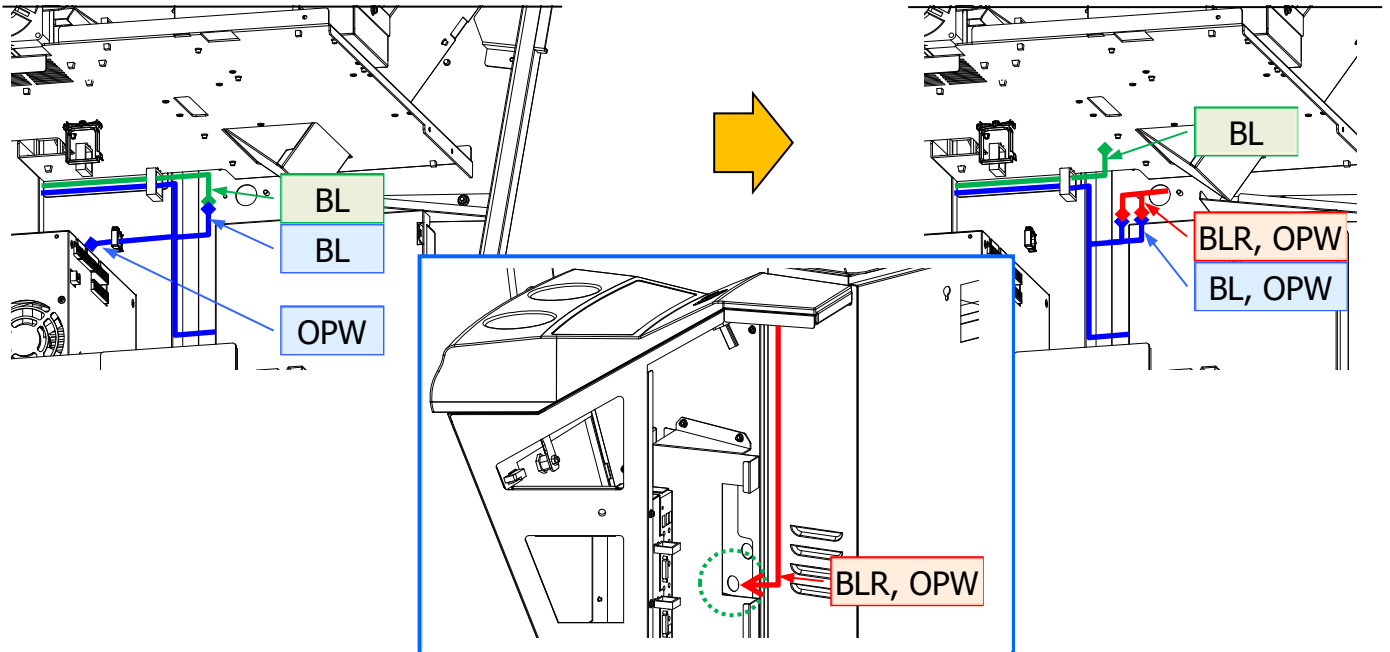

3. 2. 1. 19: Installing the Control and Drain Spacer Units to Center Unit

1. Remove 1 screw and detach the Bottom Cover on each station.

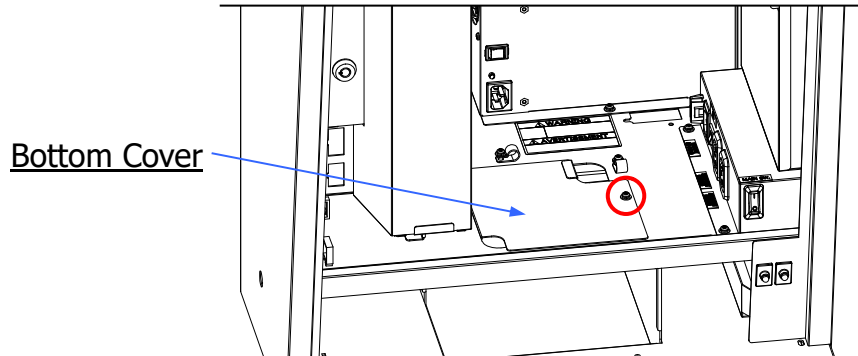

2. Prepare the following Parts.

Parts Name	Qty	Appearance
LAN Cable(for Station: 2.5m)	2	

3. Unlock the Security Cage Front Cover and connect the LAN Cable to the [LAN 2] Port indicated below. Then push the opposite head outside of the machine.

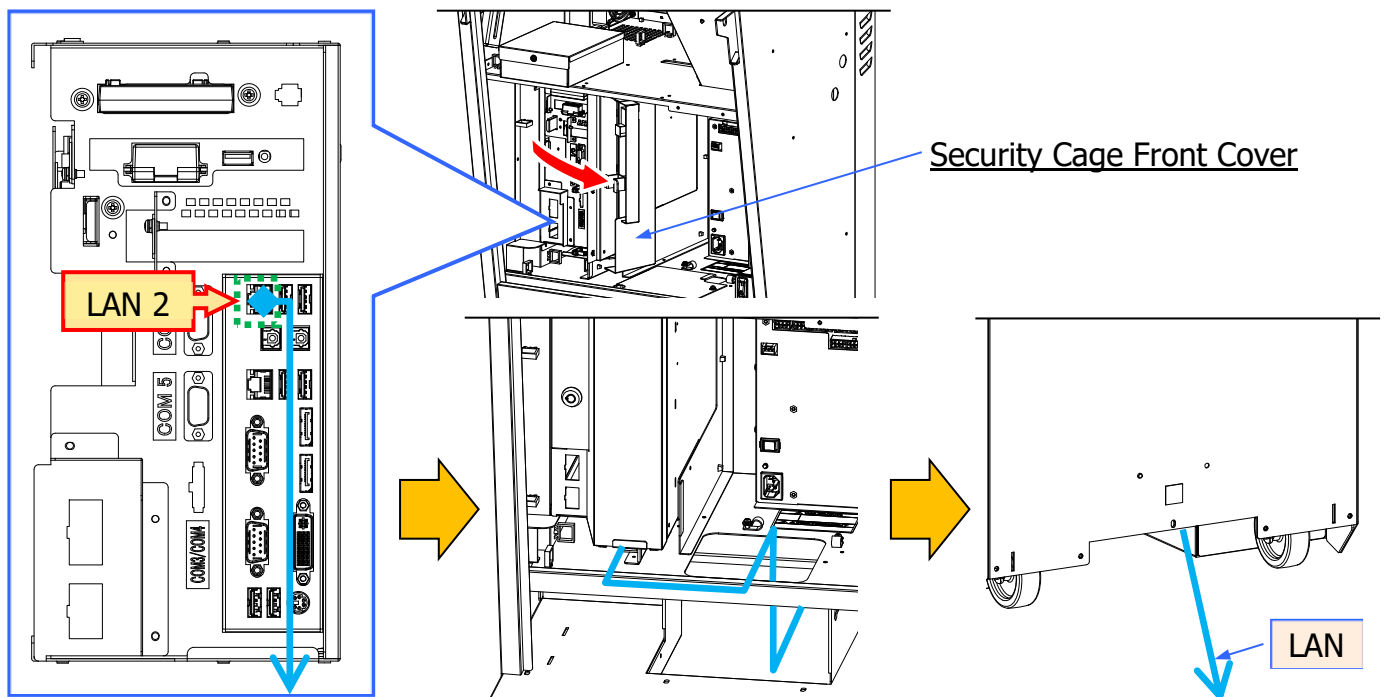

4. Move the [Station 3 Unit] close to the Corner 2, and connect the LAN Cable of [Station 3 Unit] to the LAN Port 3 of the Center Unit. In the same way move the [Station 7 Unit] close to the Corner 4 and connect the LAN Cable of [Station 7 Unit] to the LAN Port 7 of the Center Unit.

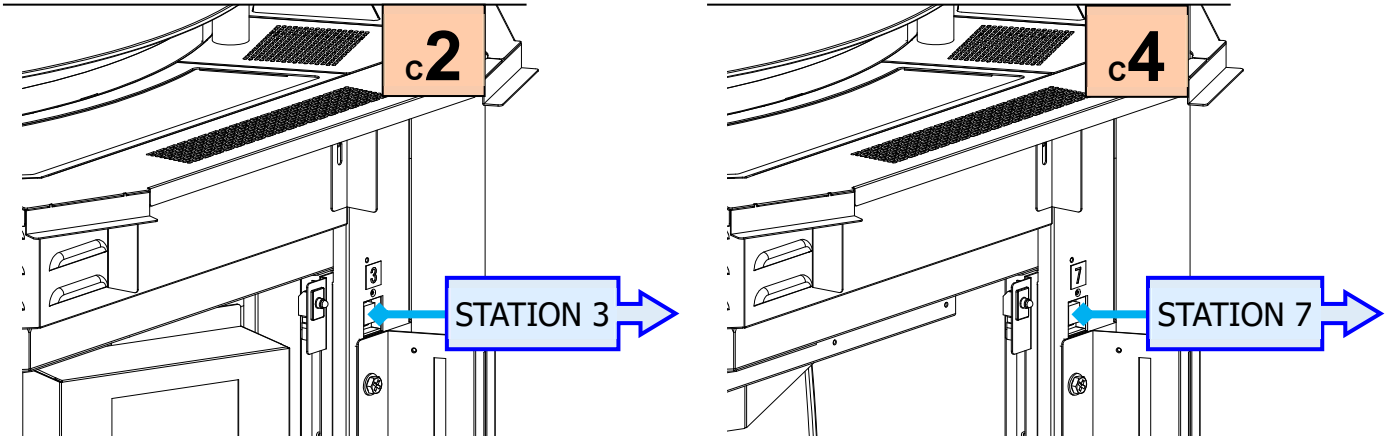

5. Start the composition of the layout by placing the [Station 3 Unit] and the [Station 7 Unit] as illustrated below.

s1 = Station
 p1 = Pole
 c1 = Corner

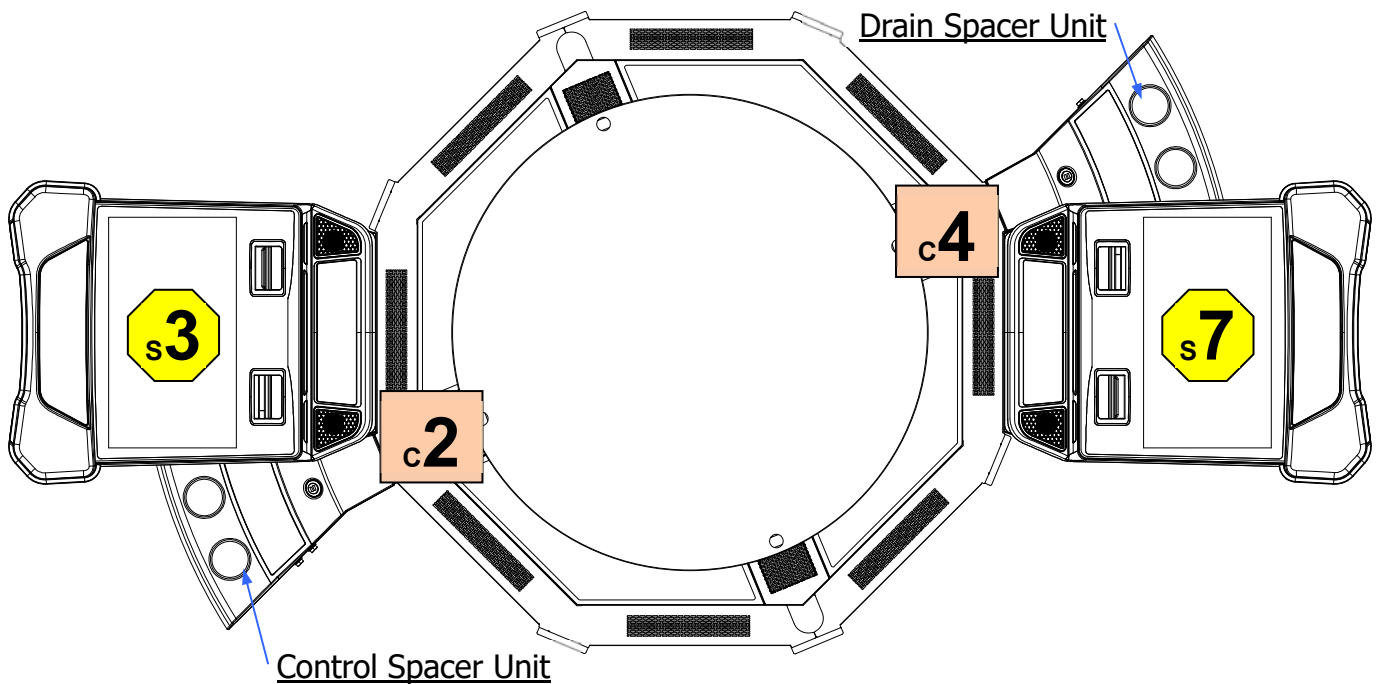

6. Affix the Control Spacer Unit and the Filterer Spacer Unit to the Center Unit by using 2 screws on each, and untie the cables that are inside each Spacer Unit.

Fasteners		Qty	Appearance
F	PAN M4x8 3P	4	

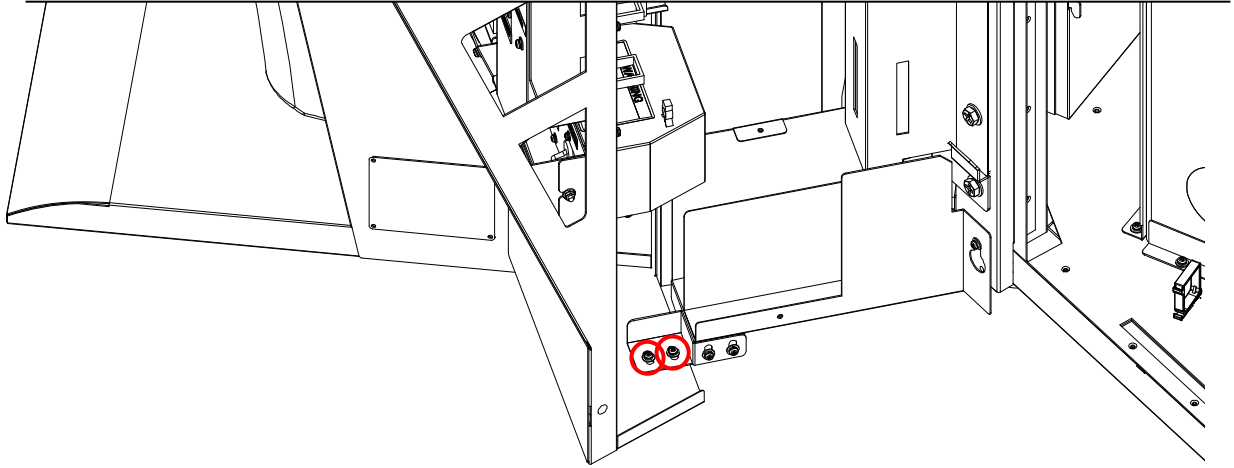

7. Thread outside the [A], [B], [CH], [D1], [DVI1(DVI1)], [DVI2(DVI2)], [DVIC(DVIC)], [USB1(KB)], [USB2(U2)] and the [Pin Plug] connectors remaining near the Corner 2 of the Center Unit, by passing through the hole at the bottom of the pole, and connect them to the [A], [B], [CH], [D1], [DVI1(DVI1)], [DVI2(DVI2)], [DVIC(DVIC)], [USB1(KB)], [USB2(U2)] and the [Pin Jack] connectors of the Control Spacer Unit.

i NOTE:

Split the paths of the Cable Line for Connectors [A] and [B] and the Cable Line for Connectors [CH], [D1], [DVI1(DVI1)], [DVI2(DVI2)], [DVIC(DVIC)], [USB1(KB)], [USB2(U2)], and the [Pin] as illustrated.

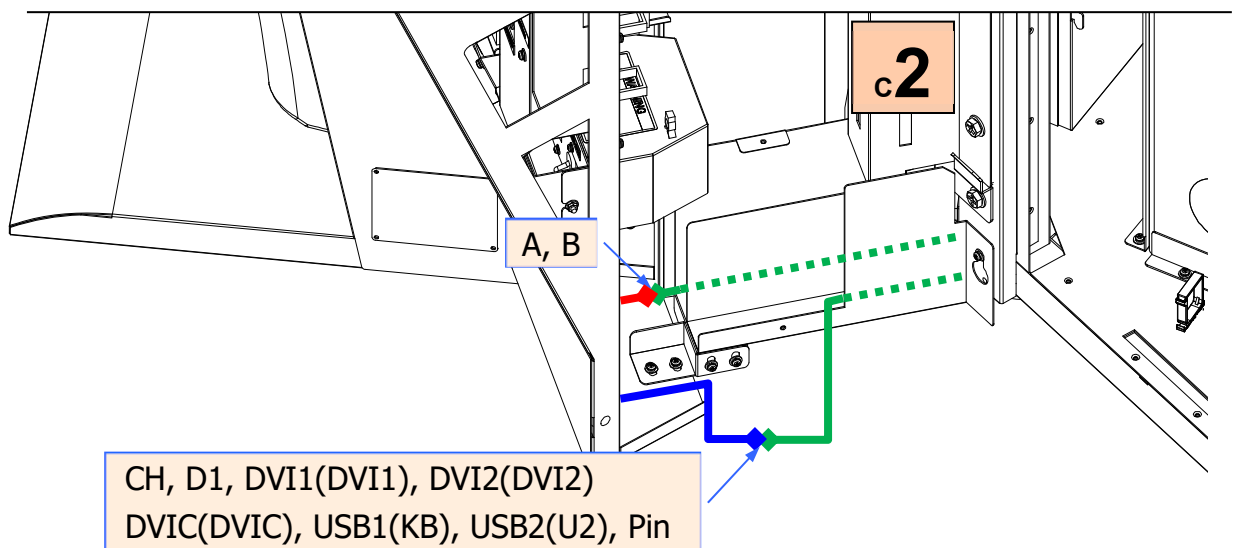
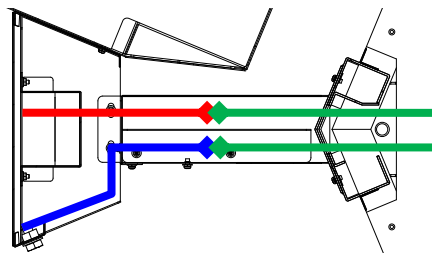

- Thread outside the [D2] connector remaining near the Corner 4 of the Center Unit, by passing through the hole at the bottom of the pole, and then connect it to the [D2] connector of the Drain Spacer Unit. Then thread outside the 2 Air Tubes that are kept inside the Center Unit, again through the hole at the bottom of the pole.

i NOTE:

Split the paths of the Cable Line for Connector [D2] and the Line of the Air TUBE as illustrated below.

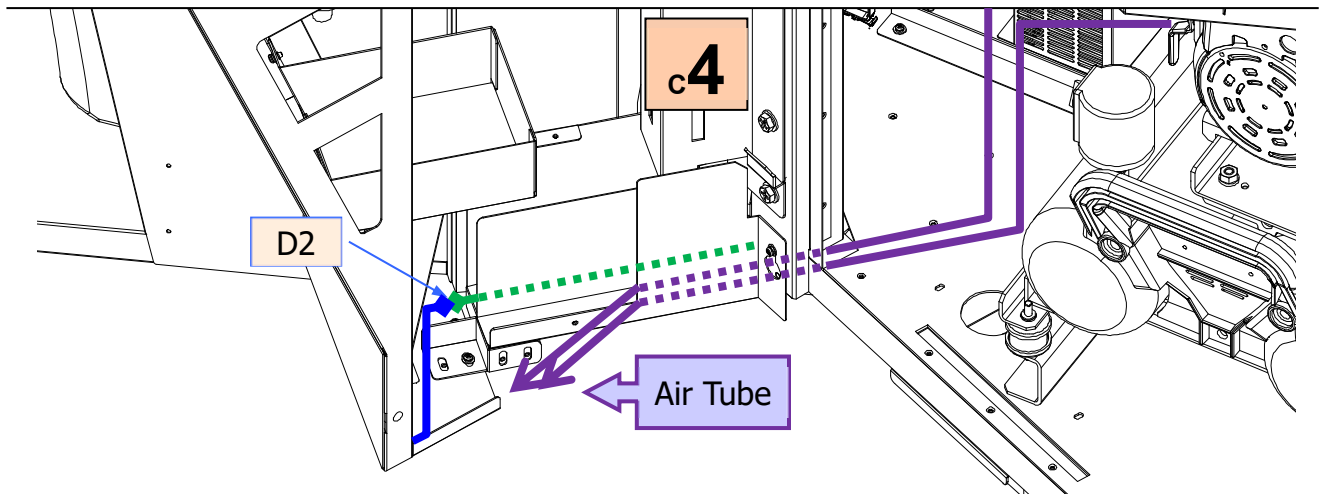
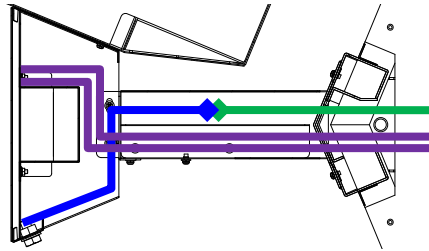

9. Connect firmly the [IN] and [OUT] Air Tubes to the Air Filter of the Drain Spacer Unit, following the IN/OUT marks.

i NOTE:

IN: from the Compressor. **OUT:** to the Wheel Unit.

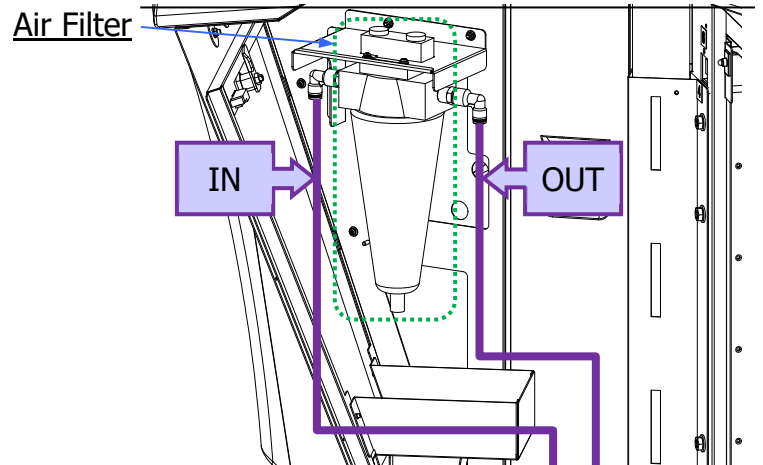

i NOTE: Option-[If using a USB Charger]

Insert the AC Adapter of the AC Cable for the USB Charger, at the bottom of the rear side of the Station.

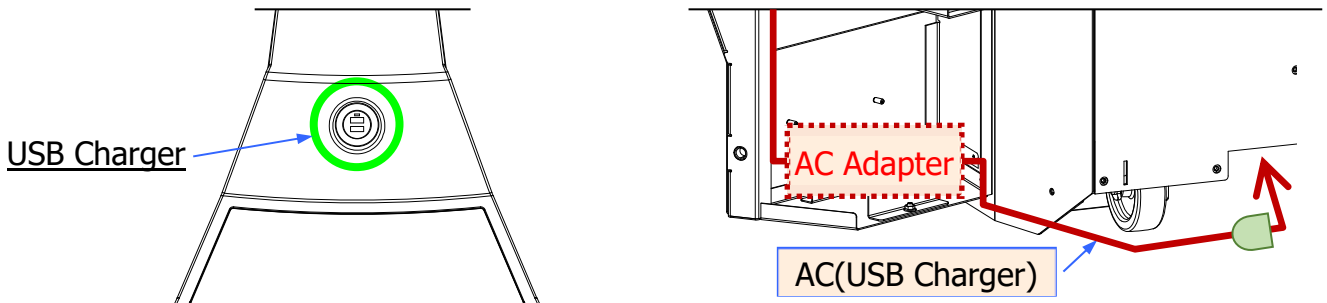

10. Prepare the following Parts.

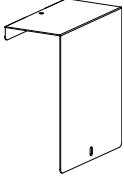
Parts Name	Qty	Appearance
Harness Cover	2	

11. Affix the Harness Covers to the Harness BRKT by using 2 screws on each, while paying attention not to pinch the cables or the Air Tubes.

Fasteners		Qty	Appearance
F	PAN M4x8 3P	4	

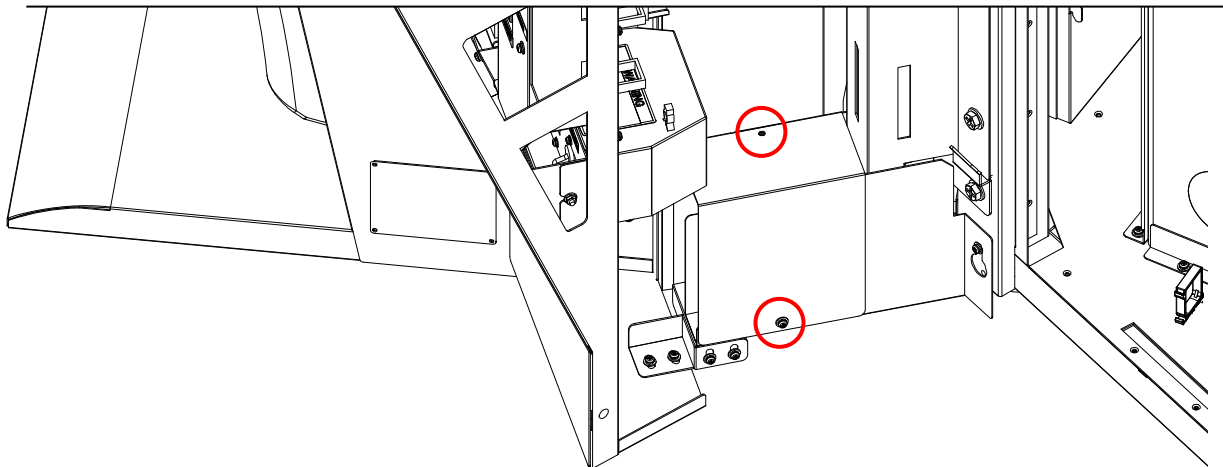

3. 2. 1. 20: Activating the Air Compressor Unit and Projector Unit

Perform a startup check of the Air Compressor Unit and of the Projector Unit before the operation check of the Center Unit.

Before turning ON the Center Unit, check the following:

- All the cable connectors are securely connected and the machine is properly grounded.

⚠ CAUTION!

Make sure that the Switch of the Air Compressor Unit and of the Main Power Box located inside the Center Unit, are switched to ON.

Please leave these switches to ON and do not change their status.

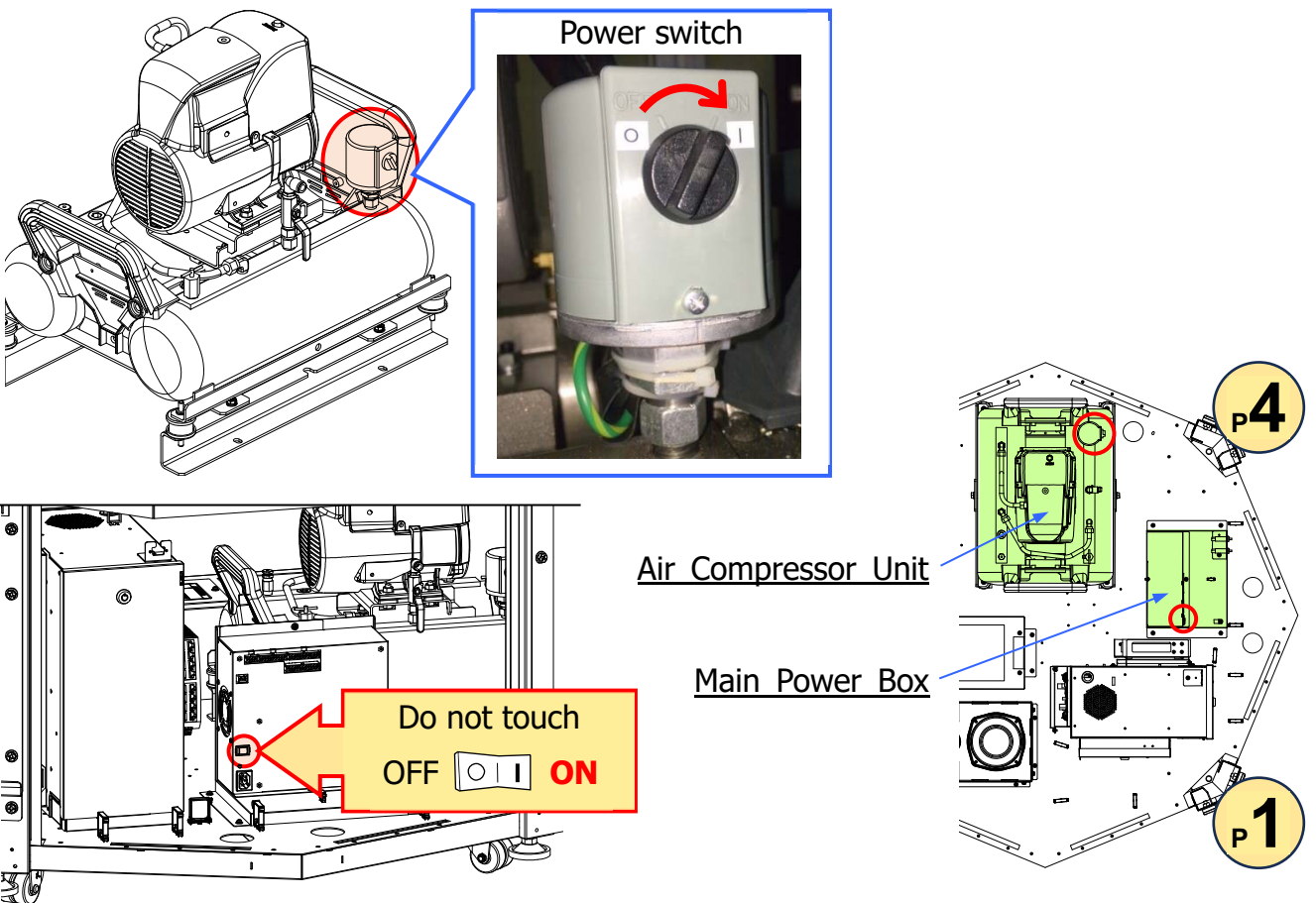

1. Locate the two shipping BRKT fixed at both sides of the air compressor unit. Remove the 2 bolts on each, and detach the shipping BRKTs.

⚠ CAUTION!

Make sure to remove the 2 shipping BRKTs before operating the air compressor unit, make sure not to lose the BRKTs.

The cushions that support the air compressor unit can be easily damaged, therefore when moving the machine, always re-install the 2 shipping BRKTs in their original position.

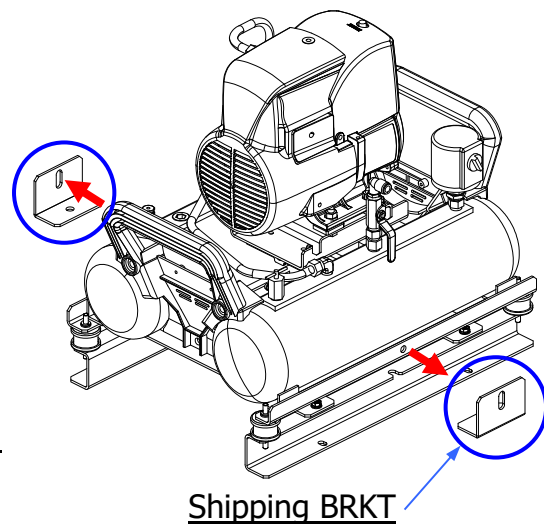
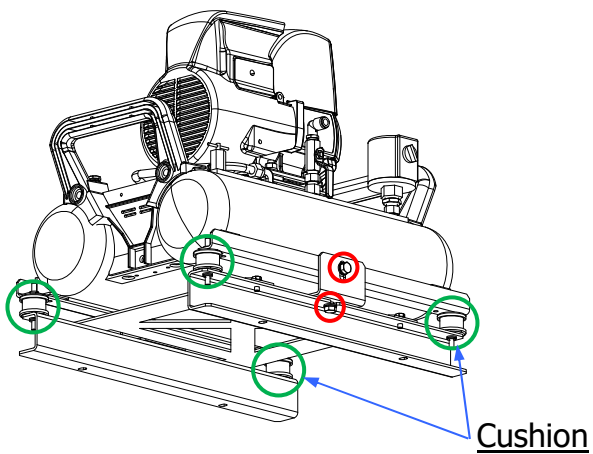
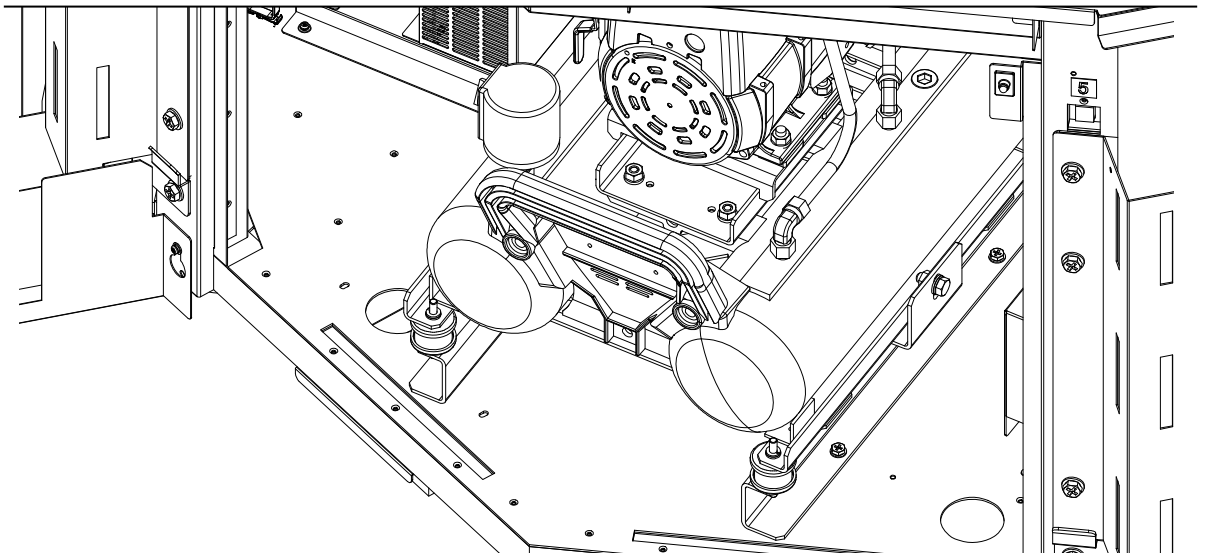

2. Check that there is no damage, deformation or pinching of the air tubes of the compressor.
3. Close the air compressor unit lever.

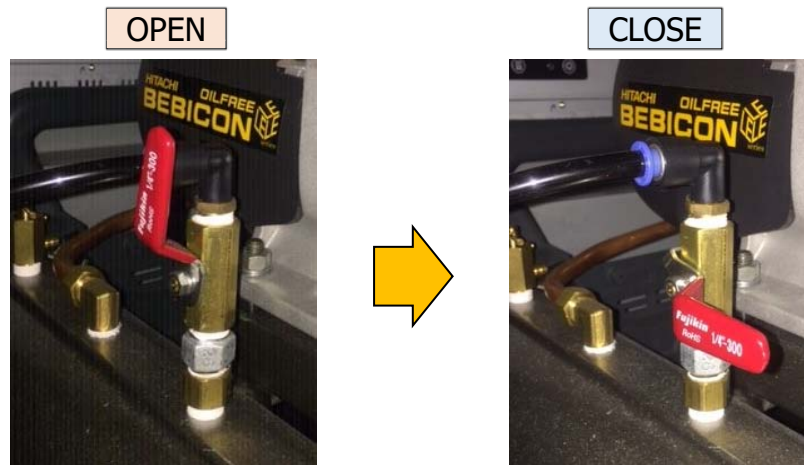

4. Check that the air tube is securely connected.

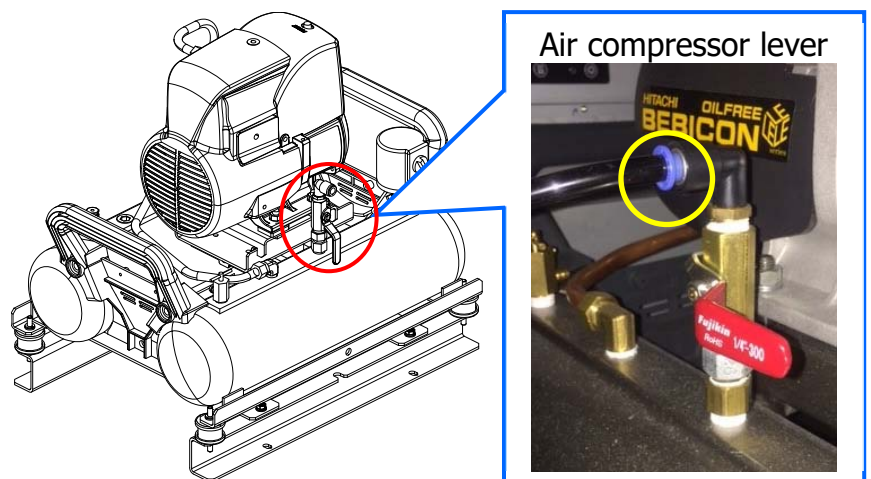

5. There are 3 or 4 pieces of tape place on the inner side of the Wheel Unit (inside the Cabinet) to stop the Wheel rotation. Peel off all of them. Turn the Wheel with your hand to make sure that to residue of tape is left on the wheel.

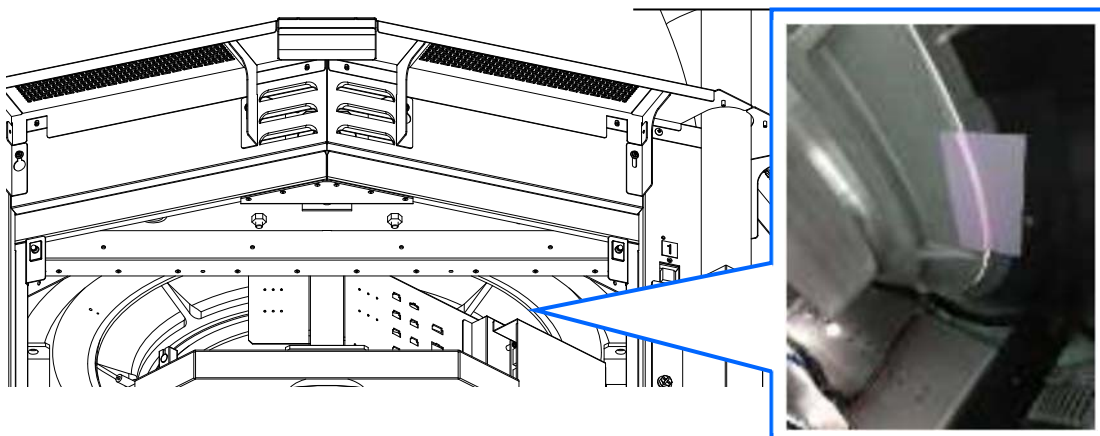

- First turn ON the power source. The devices directly connected to the power source will boot up.

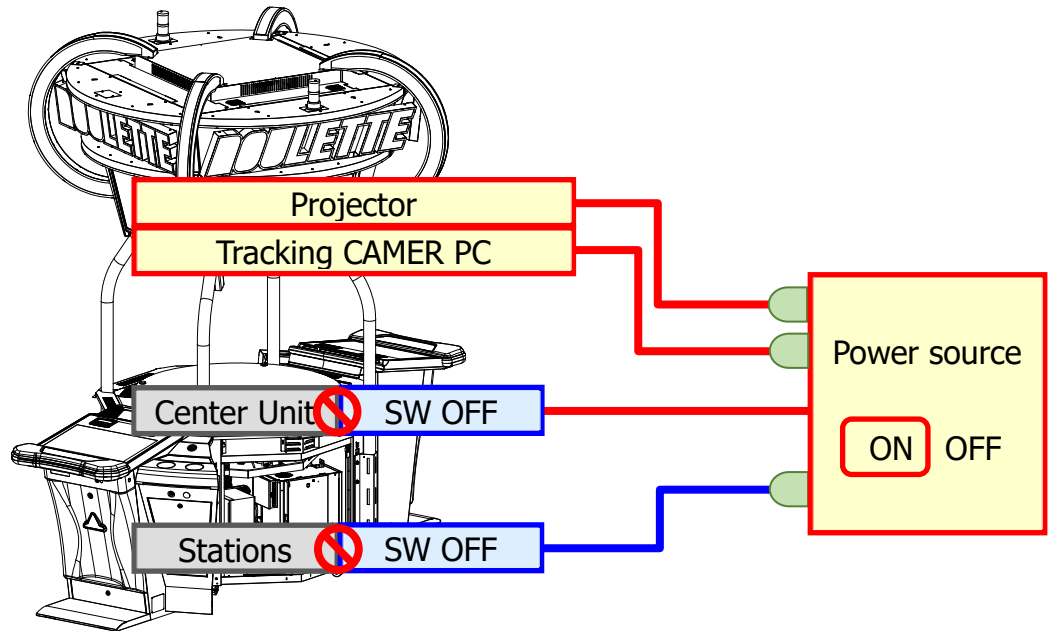

- Unlock and detach the Control Spacer Door. Turn ON only the Power Switch on the right (MAIN SW 2), and the Air Compressor will start working. Wait until the Air Compressor Unit is in Standby mode, and then turn OFF the Power Switch (MAIN SW 2)

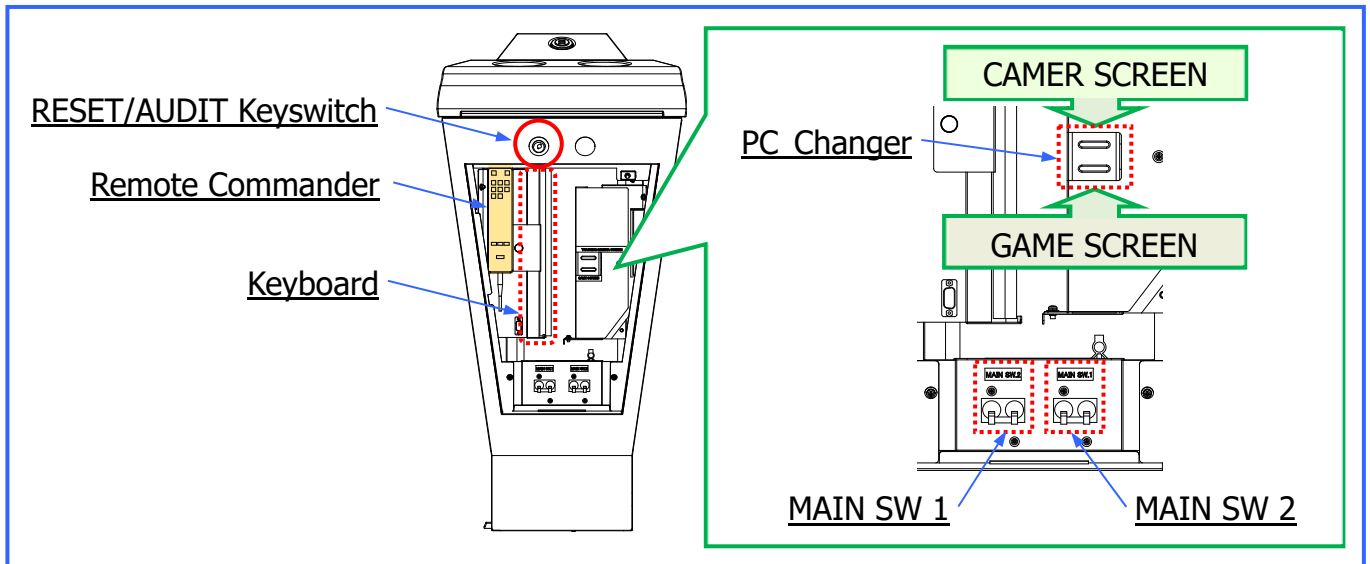

CAUTION!

When doing "Power OFF-ON" wait at least 15 seconds before power On.

8. Locate the vent of the drain valve, and wrap it with waste cloth. Open slowly the drain valve, and it will discharge the filthy air that was inside the air tank.

⚠ CAUTION!

Pay attention to the rust that from inside the tank may be spread outside during the air discharge.

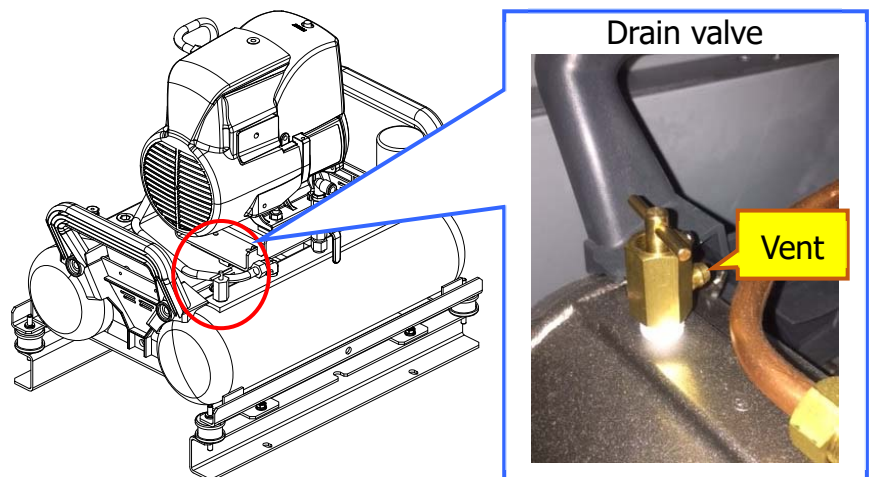

9. When the air discharge ends, close the drain valve.
10. Open the Air Compressor Unit Lever.

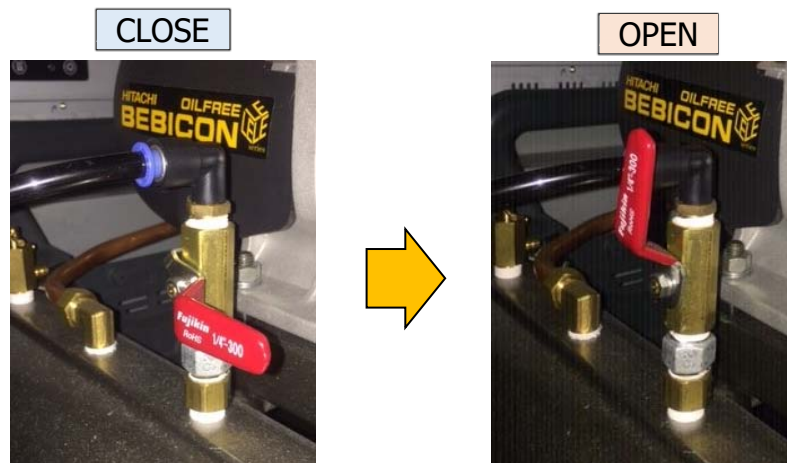

11. Check if the Projector Unit is working. Refer to the Appendix of the SERVICE Manual Appendix **"Projector User's Manual"** and adjust the image by using the Remote Commander of the Projector contained inside the Control Spacer Unit.

Setting of Projector	DESCRIPTION
LENS SHIFT	Move the lens (the image) in each direction.

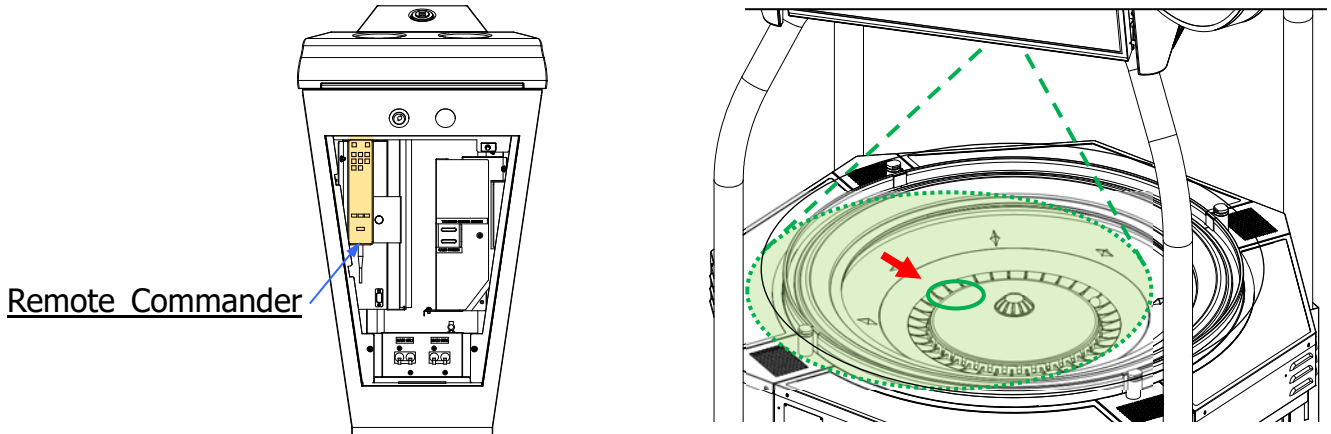

12. Open the Lens Door by removing the 2 screws.

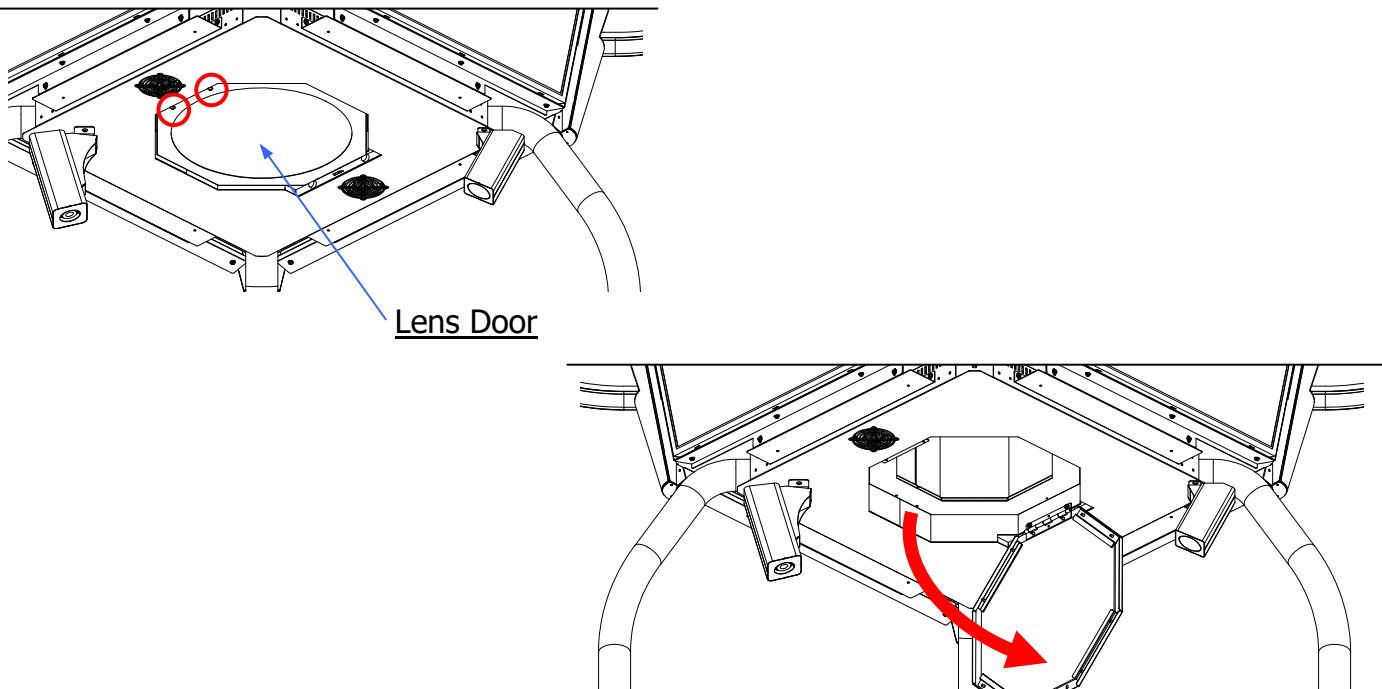

13. Locate the Lens barrel of the Projector, placed 350 mm inside the cavity behind the Lens Door.

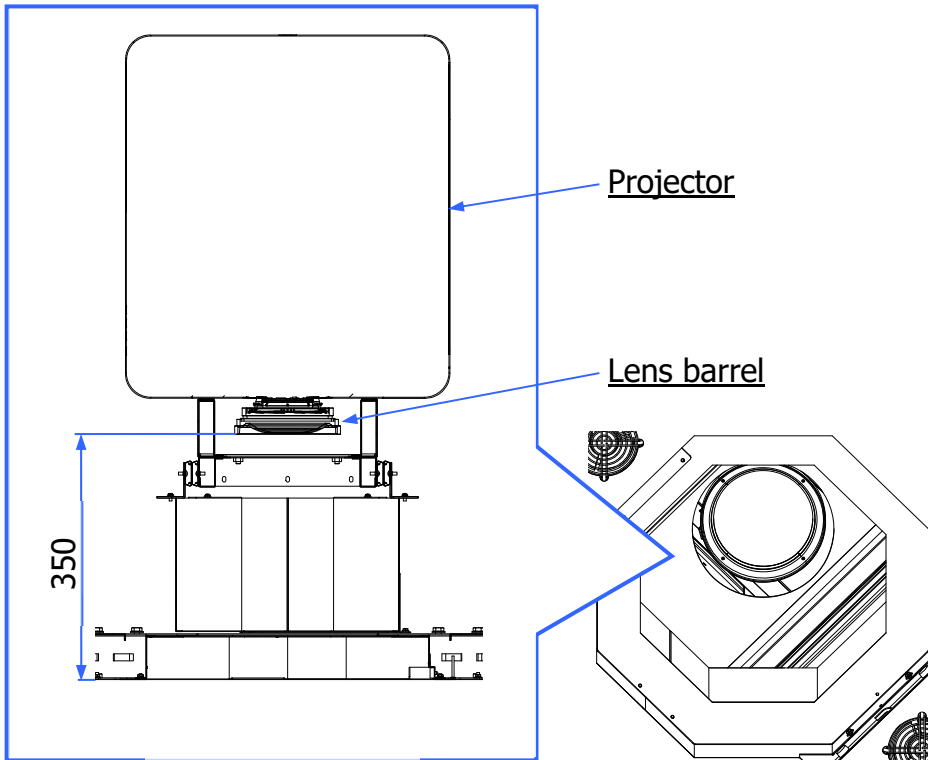

14. Refer to the Appendix of the SERVICE Manual "**Projector User's Manual**" and adjust the focus and the size while watching the images projected on the Center Unit. Then close the Lens Door.

i NOTE:

※To correctly project the images, use the Zoom to fit the area as indicated in the illustration on the right.

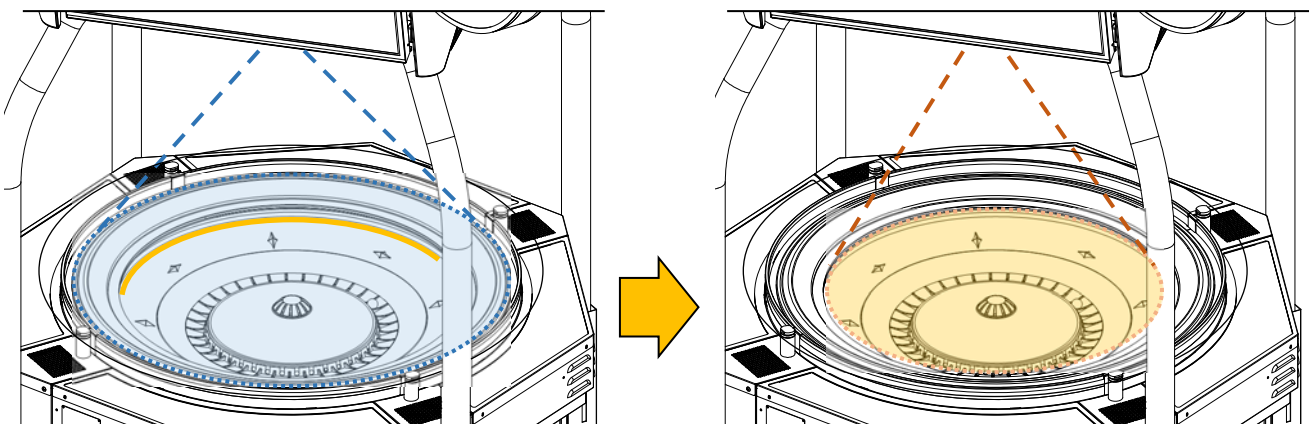

The light is reflected

The image is shrunk enough that the light is not reflected

3. 2. 1. 21: Checking Operation of the Center Unit – 1st Step

Check the functioning of the Center Unit before the installation of the Stations.

1. To change the AUDIT settings of the Center Unit, unlock and remove the Security Cage Door inside the Center Unit.



CAUTION!

For specific jurisdictions, to configure the **“IMPORTANT SETTING (BASIC SETTING)”** and the **“PROGRESSIVE SETTING”** described below, a [Setting GAL Cassette] and a [Setting Password] are necessary. Refer to **“Configuring Settings by using a Setting GAL :for Nevada/Arizona”** on chapter 6 of the SERVICE Manual to configure these settings, and change the GAL with the Setting GAL Cassette.

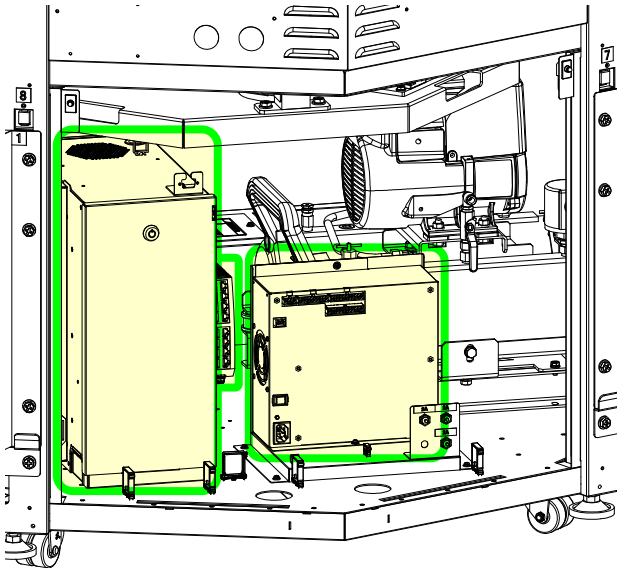

- Turn ON the Power Switches (MAIN SW 1 and MAIN SW 2) of the Control Spacer Unit. Push the [GAME SCREEN] switch of the PC Changer. The GAME screen will be displayed on the Monitor of the Top Base Unit.

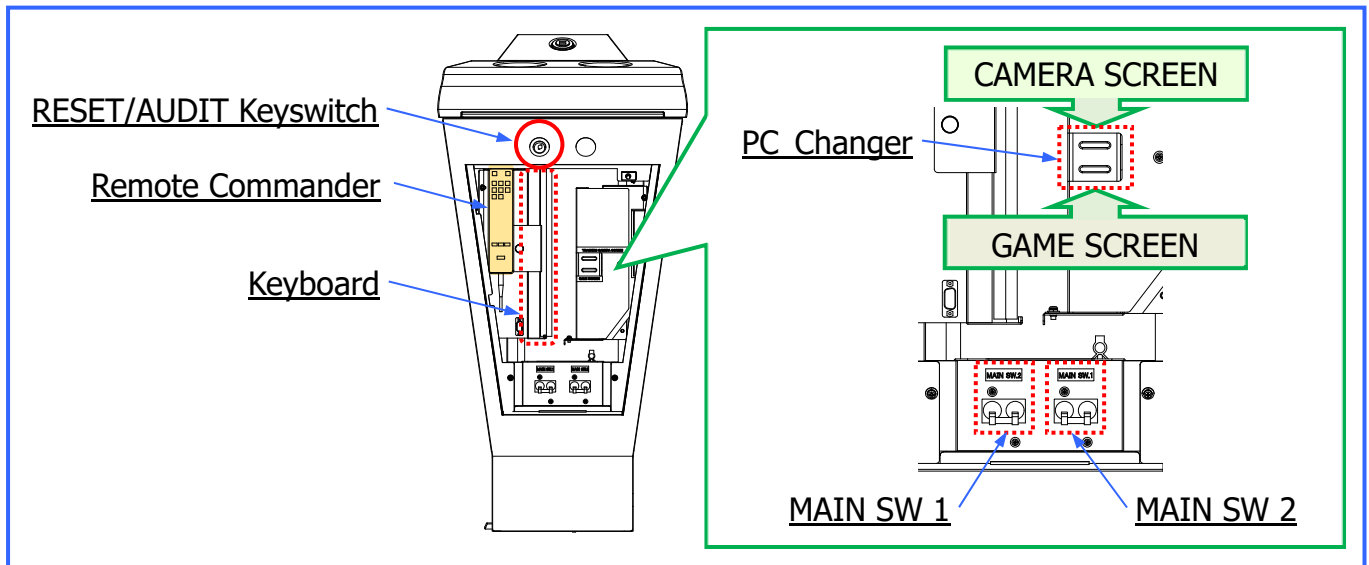

CAUTION!

- Do not turn ON the 2 Power switches at the same time. Doing so can result in a start-up error of the machine.
- When doing "Power OFF-ON" wait at least 15 seconds before power On.

NOTE:

- If an error appears during the POWER UP SELF TEST, the activation of the Machine halts. Refer to OPERATION Manual Chapter 8 "Error Messages" to clear it.
- If it is necessary to perform the RAM Clear (Memory Clear), refer to "Memory Clear Procedure" on Chapter 6.

- Are there any strange sounds or smells coming from the machine?
- Test the proper functionality of Sensors, RESET/AUDIT key switches etc.

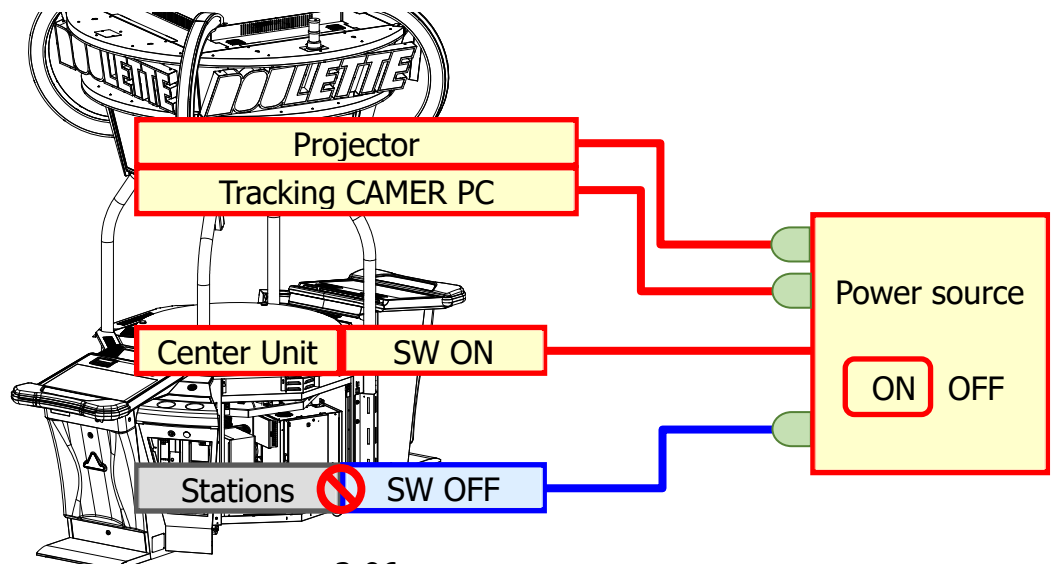

- To call the AUDIT mode, turn the key to the AUDIT position, and return it to the neutral position.



- Refer to "**Version Information**" at Chapter 6 of the OPERATION Manual, to check that the Software version is the same as the Software Version approved for installation.
- Refer to "**Settings**" at Chapter 4 of the SERVICE Manual to perform all the necessary settings.

i NOTE:

IMPORTANT SETTINGS

ONLINE SYSTEM SETTINGS

The settings above require a **[reboot]**, therefore it is necessary to pay attention at the order the settings are inputted. Please follow the procedure below.

- First, complete only the settings above (listed in green uppercase fonts). (If the machine runs a Game as **<<LUCKY ROULETTE>>** that includes a PROGRESSIVE function, set at "NUMBER OF STATIONS" the total number of stations including the Extension Stations (if any is installed).) When completed, press the [RETURN TO PREVIOUS MENU] button, and exit [SETTINGS] once.
- The display will change to the following screen. Press [SAVE and SHUTDOWN] button. The Center Unit will turn into standby shutdown.

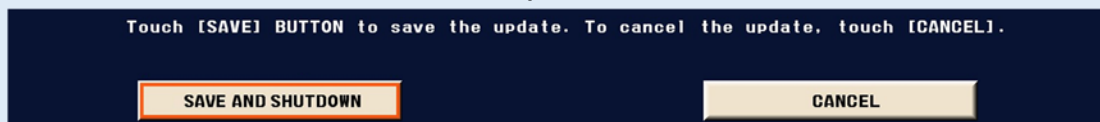

- ✘ If the GAL was changed to a Setting GAL Cassette, at this point of the procedure change it back to the original game GAL Cassette.
- Turn OFF and ON the Power Switch of the Center Unit and do **[reboot]**. Close the Security Door of the Center Unit. (When doing "Power OFF-ON" wait at least 15 seconds before power On.)
 - Open again the AUDIT [SETTINGS] and perform the remaining settings. When completed, press [RETURN TO PREVIOUS MENU] to return to the TOP MENU.

i NOTE: Option-[In case it is planned to extend the number of stations]

Change the setting from [8], the "original (DEFAULT)" to the total number of stations, by adding the number of expansion stations. (Example: in case of 4 Extension stations, set $[8]+4=[12]$).



i NOTE:

Refer to "LIVE CAMERA TYPE", "LIVE CAMERA ADDRESS", "LIVE CAMERA SETTINGS" and "LIVE CAMERA ERROR" inside "**Main Unit Settings**" to set the Live Camera. If the condition requires it, partially unscrew the screws at the feet of the Live Camera Unit, to adjust its position and angle.

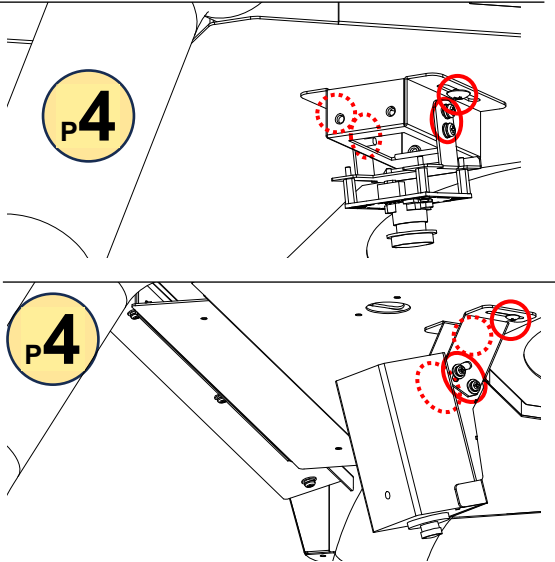

Reference image "LIVE CAMERA SETTINGS"

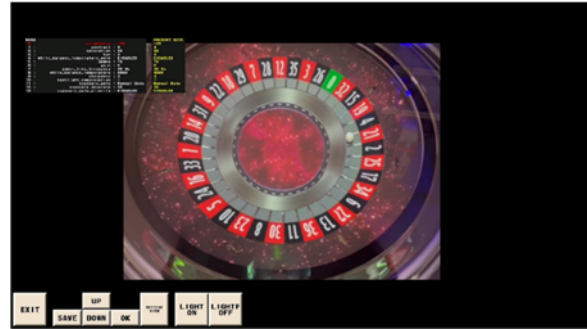

3. 2. 1. 22: Remove the Top Glass, Check the Machine and insert the Ball

1. Prepare the following Parts.

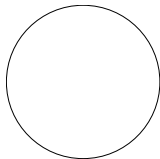
Parts Name	Qty	Appearance
Ball (for Roulette)	1	

2. Remove the 4 Post B Bolts from the Top Glass, then remove the Top Glass and insert the Ball.

i NOTE:
Use a wrench to remove the Post B Bolts toward upside.

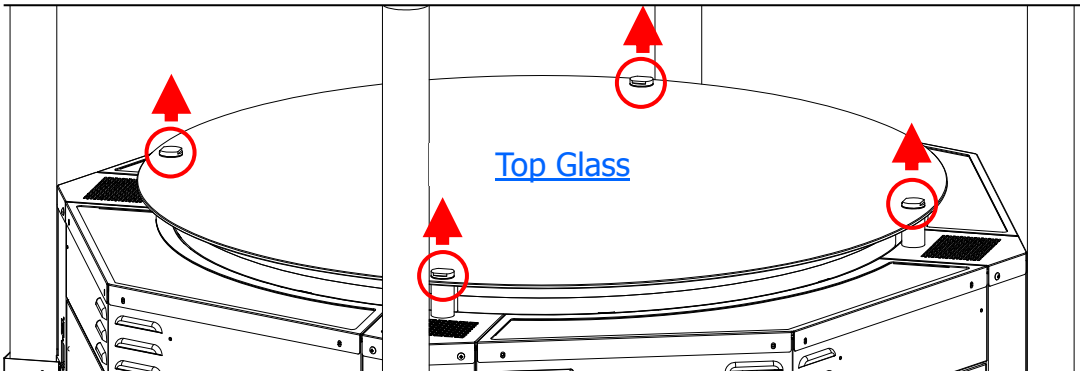

3. Check the Bank (green), Number (yellow) and pockets (red) surface for stains, dents, scratches, air bubbles, excessive wear, etc.



4. Check that there is no dust nor stain on the sensors and the holes (4 inside and 2 outside).

(Inside)

(Outside)



5. Refer to **"ROULETTE UNIT TEST"** on SERVICE MANUAL Chapter 4 to confirm that the 9 sensors below are working correctly.

No	Sensor Name	Sensor Position
1	AROUND SENSOR 1 Wheel around sensor O1200	
2	ENCODER SENSOR 1	
3	ZERO SENSOR	
4	ENCODER SENSOR 2	
5	POSITION SENSOR4(REF1030) Pocket sensor I1030	
6	POSITION SENSOR1(REF0730) Pocket sensor I0730	
7	AROUND SENSOR 2 Wheel around sensor O0600	
8	POSITION SENSOR3(REF0430) Pocket sensor I0430	
9	POSITION SENSOR2(REF0130) Pocket sensor I0130	

6. When the procedure is completed, return the **Top Glass to its previous position.**
7. With the Top Glass installed, check the items indicated by "After installation" on the **"Machine check list (Lucky Roulette)"** chart, and then perform the following:
- Checking Ball Operation**
 - Adjusting the Air Pressure for Ball Rise**
 - Adjusting the Air Pressure for Ball Rotation**

#	Machine check list (Lucky Roulette) Item Name	After installation	Periodic inspection	Replacement cycle
1	Drain box	<input type="radio"/>	1 week	
2	Ball condition	<input type="radio"/>	1 months	3 months
3	Pocket shuffle		3 months	
4	Cleaning inside cabinet	<input type="radio"/>	3 months	
5	Cleaning glass	<input type="radio"/>	3 months	
6	Bank sheet condition	<input type="radio"/>	3 months	36 months
7	Number sheet condition	<input type="radio"/>	3 months	36 months
8	Pocket sheet condition	<input type="radio"/>	3 months	36 months
9	Ball pocket and wall condition	<input type="radio"/>	3 months	
10	Wheel pin (Cat's eye) condition	<input type="radio"/>	3 months	
11	Center cap condition (Crack,distortion)	<input type="radio"/>	3 months	36 months
12	Wheel level	<input type="radio"/>	3 months	
13	Ept Sealer of the canter cap	<input type="radio"/>	6 months	12 months
14	Sensor hole condition	<input type="radio"/>	6 months	
15	Clearance between bank and pocket	<input type="radio"/>	6 months	
16	Gap between bank and pocket	<input type="radio"/>	6 months	
17	Dead rebound position	<input type="radio"/>	6 months	
18	Roller Assy and motor (Wheel)	<input type="radio"/>	6 months	24 months
19	Fiber sensors condition	<input type="radio"/>	6 months	
20	Projector filter condition	<input type="radio"/>	6 months	12 months
21	Tracking ball condition	<input type="radio"/>	6 months	
22	Compressor filter condition	<input type="radio"/>	3 months	6 months
23	Compressor condition	<input type="radio"/>	12 months	5 years
24	Separator filter(corner) condition		6 months	12 months
25	Air pressure and ball rotation	<input type="radio"/>	6 months	
26	Air regulator condition	<input type="radio"/>	6 months	24 months
27	Air tube condition	<input type="radio"/>	6 months	36 months
28	Air nozzle condition	<input type="radio"/>	6 months	36 months
29	Projector (Placement/angle of image,focus)	<input type="radio"/>	6 months	24 months
30	Projector setting before shipment		-	
31	Live camera image (Focus, blur, brightness)	<input type="radio"/>	6 months	
32	Perform I/O test	<input type="radio"/>	6 months	
33	Confirm error meter	<input type="radio"/>	6 months	
34	RNG test (10000games)		-	
35	Wheel unit (Repair)		-	36 months

3. 2. 1. 23: Checks during operation

WARNING!

Operation of the machine without the following check could potentially cause serious financial loss to the casino.

1. Select **TEST>ROULETTE UNIT TEST>AUTO RUN**. Perform the aging test for at least 10 minutes, refer to "ROULETTE ERRORS" inside "**ERROR METERS**" at OPERATION Manual Chapter 6, to check if any error occurred.

AUDIT>MAIN METERS>ERROR METERS>ROULTTE ERRORS

CALL SERVICE IMMEDIATERY!

If the following Critical errors happens even one time, turn immediately OFF the machine and contact the Customer Technical Support or your nearest distributor.

GAME INIT ERROR

BALL START ERROR

BALL FALL ERROR

COMPRESSOR ERROR

BALL COUNT ERROR

MOTOR ERROR

POSITION SENSOR ERROR (REF0130): (REF0430): (REF0730): (REF1030)

ZERO SENSOR ERROR

ZERO SENSOR DETECT ERROR

AROUND SENSOR ERROR

ENCODER COUNT ERROR

POCKET SHUFFLE ERROR

WHEEL ORIGIN DETECT ERROR

WHEEL DIRECTION ERROR

※When there is no problem, the setting has been completed.

3. 2. 1. 24: Checking Operation of the Center Unit – 2nd Step

1. Return the doors of the Center Unit to their original position.

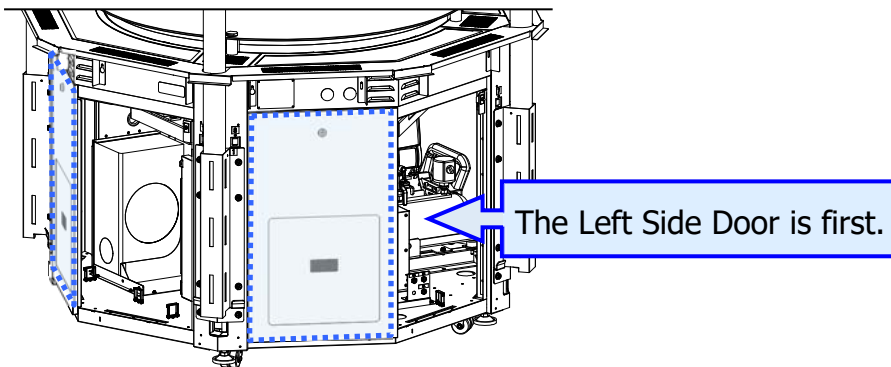

2. Push the [CAMERA SCREEN] switch of the PC Changer so that the screen of the Tracking Camera PC will be displayed on the Monitor of the Top Base Unit.

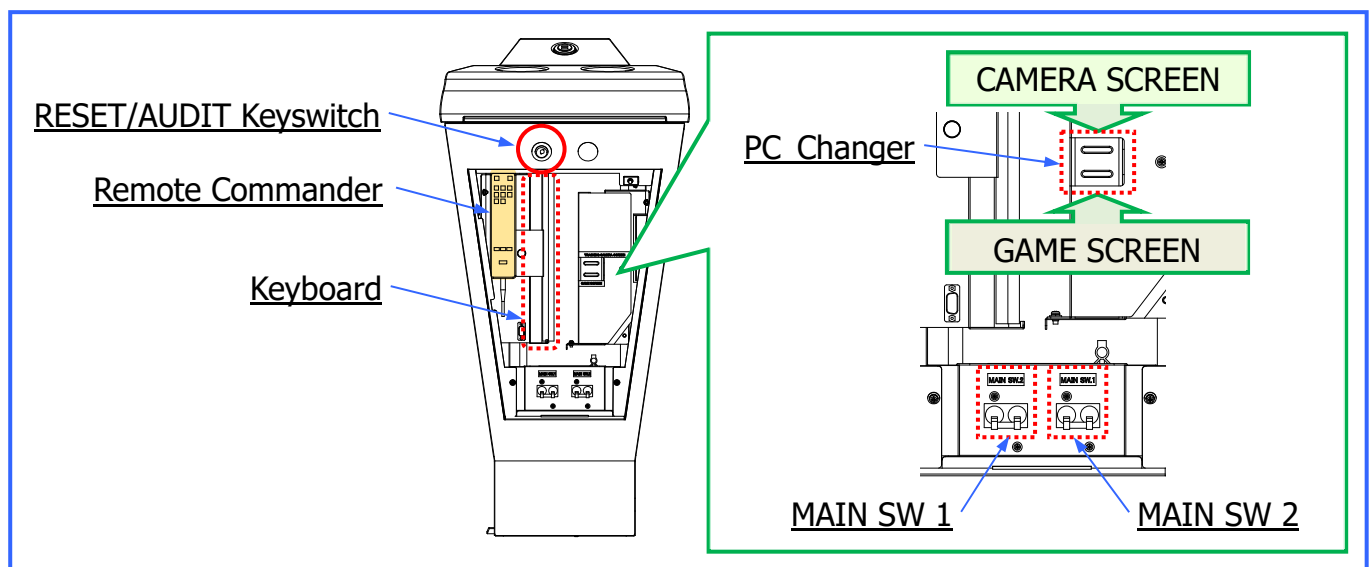

3. Refer to the Appendix of the SERVICE Manual "**HS CAMERA setting Instruction**" and set the Tracking Camera by using the Keyboard located inside the Control Spacer Unit.

NOTE:

- If it is necessary to reboot the PROJECTOR or the Tracking Camera PC, disconnect the AC Plug of the PROJECTOR or the Tracking Camera PC from the power source (power OFF), and then reconnect it (power ON).
- According to the condition of the Tracking Camera, adjust its angle by loosening the nut on its support.

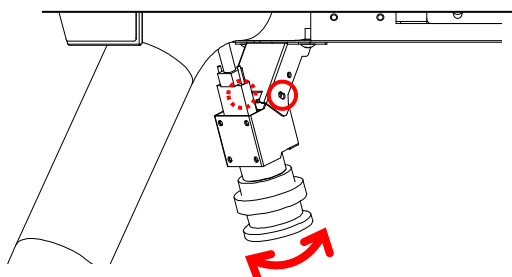

4. After the setting of the Tracking Camera push the [GAME SCREEN] Switch on the PC Changer, so that on the Monitor of the Top Base Unit will be displayed the GAME screen.
5. Refer to "**Test**" on Chapter 4 of the SERVICE Manual to check the functionality of each part.

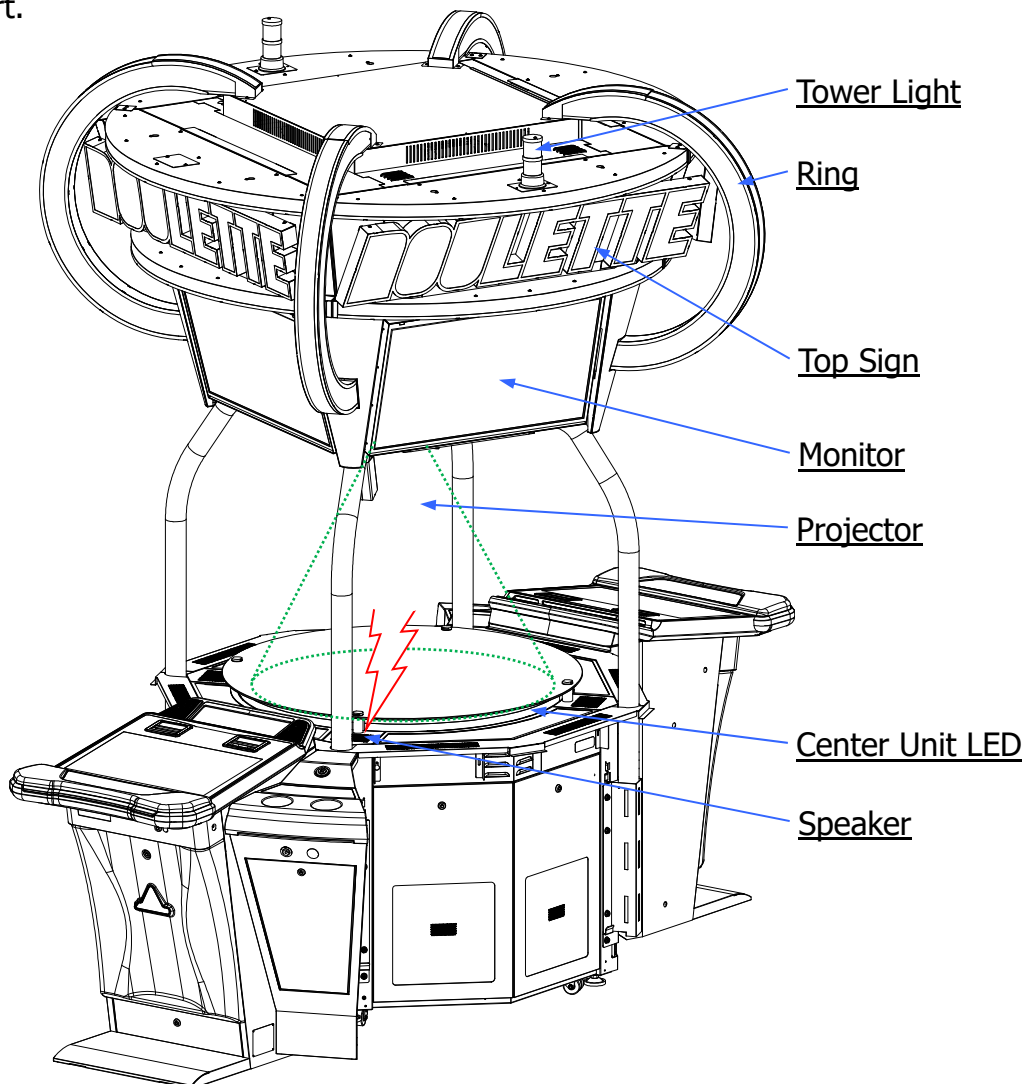

- Exit the Audit and close the Control Spacer Door. Check that the Voice sound and the Background Music can be heard.

i NOTE:

If a [GAME FAILURE ERROR] error appears, clear the error by turning the key to the RESET position, and returning it to the neutral position.

If the above check points are cleared, the functionality test of the Center Unit is finished.

Turn OFF all the Power switches of the Center Unit (MAIN SW 1 and MAIN SW2) and then turn OFF also the power source

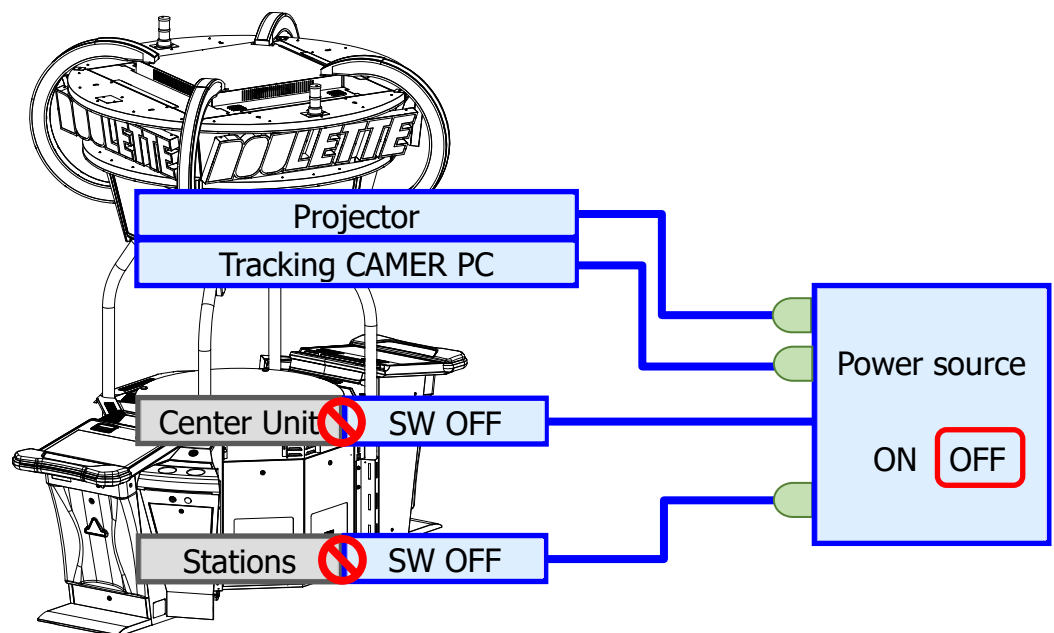

- Return the Tracking Camera Cover and the Live Camera Cover, that were detached at 3.2.1.11, to their original position by using the screws that were removed.

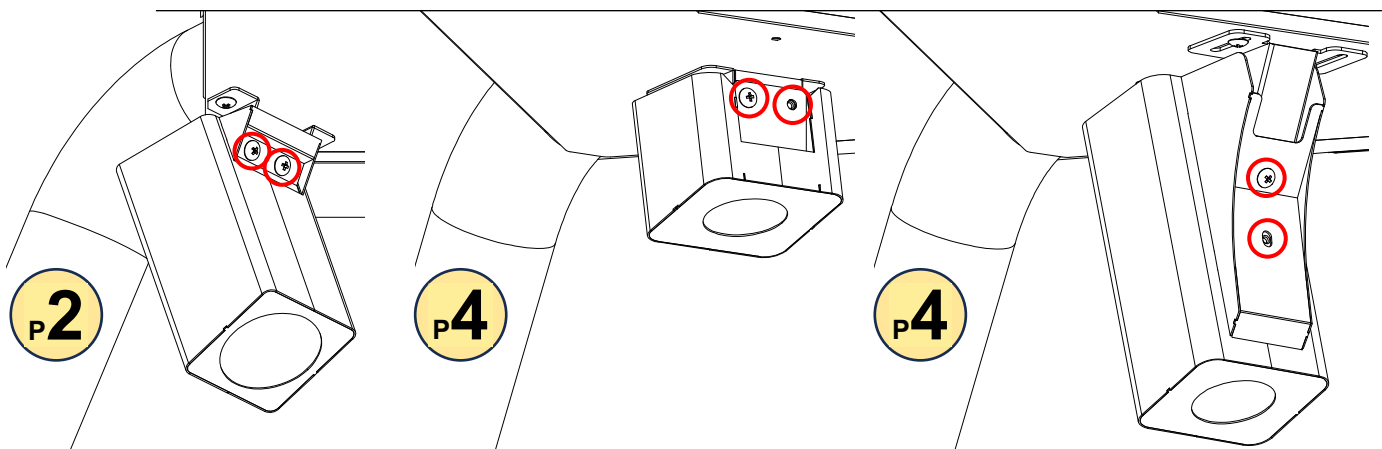

3. 2. 1. 25: Installing the Monitor Bezel

1. Prepare the following Parts.

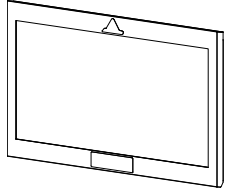
Parts Name	Qty	Appearance
Bezel (Disassembled in 3.2.1.9)	4	

2. Hang the hooks on the back of the Bezel to the slits in the Monitor Unit.



CAUTION!

Hold the Bezel with your hands until you are sure that the hooks are firmly hung to the slit.

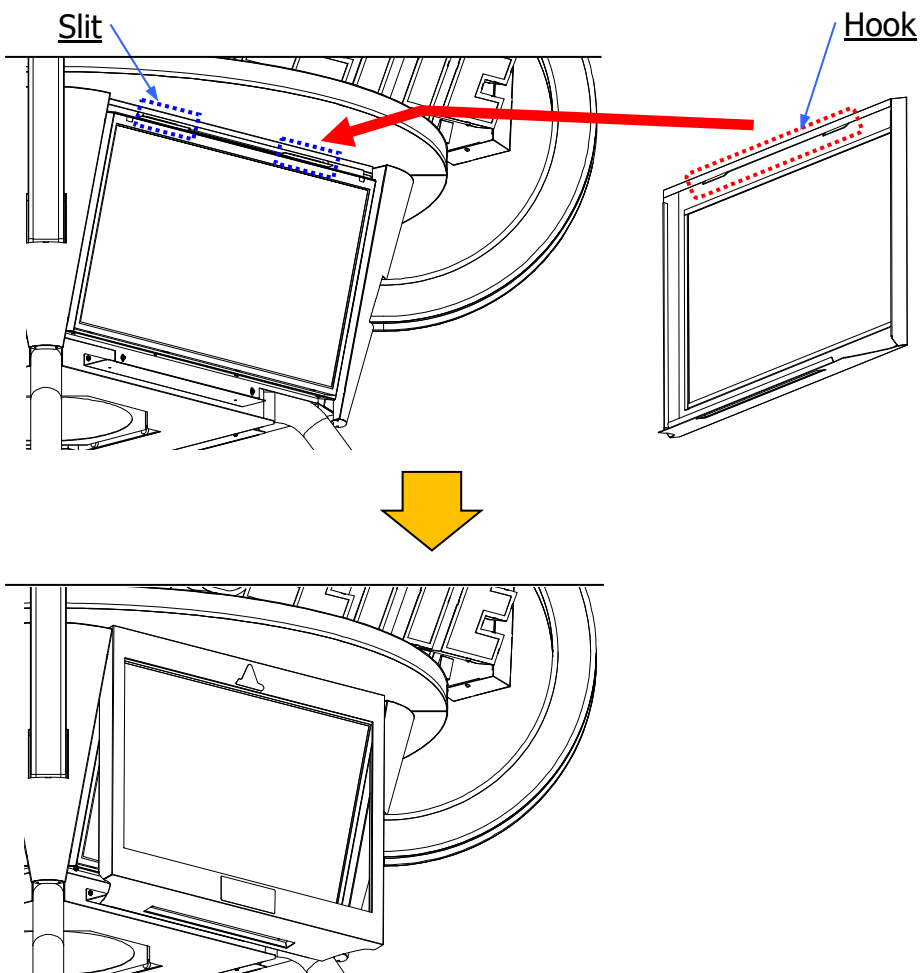

3. Affix the Bezels to the Monitor Unit by using 2 Screws for each.

Fasteners		Qty	Appearance
Bb	TRUSS M4x10 BLK	8	

i NOTE:

Pay attention not to damage the USB (HSC) Cable connected to the Tracking Camera, and install the Bezel.

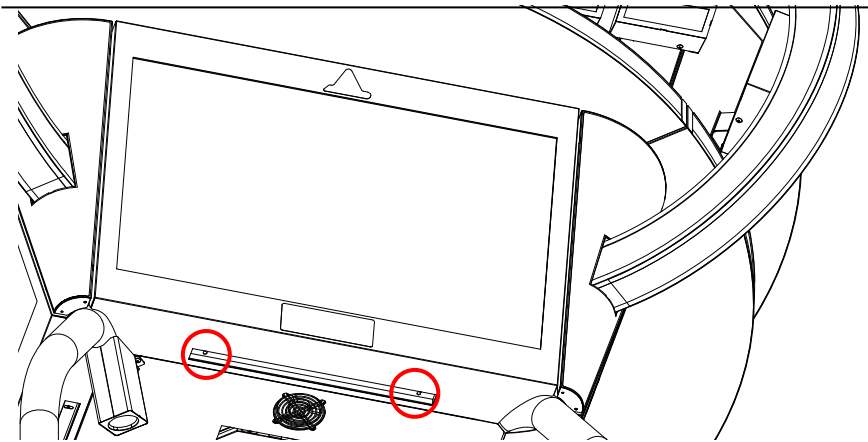

3. 2. 2: Stations

3. 2. 2. 1: Attaching the Spacer Units for the other Stations

1. Prepare the following Parts.

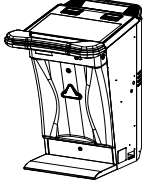
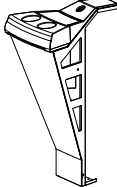
Parts Name	Qty	Appearance
Stations (STATION No.01, 02, 04, 05, 06 and 08)	6	
Spacer Units (RIGHT FILLER OF STATION No.01, 02, 04, 05, 06 and 08)	6	

2. Unlock and remove the Front Door and Bottom Door of each station.

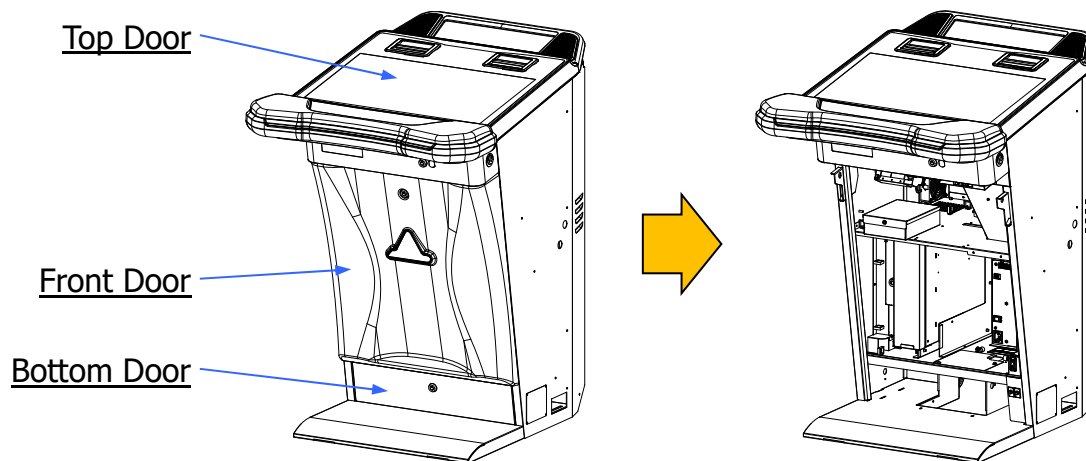

3. Affix the [RIGHT FILLER OF STATION No.x] to the right side of the [STATION No.x] by using 4 screws. The Station will become [Station x Unit].

Fasteners		Qty	Appearance
F	PAN M4x8 3P	24	

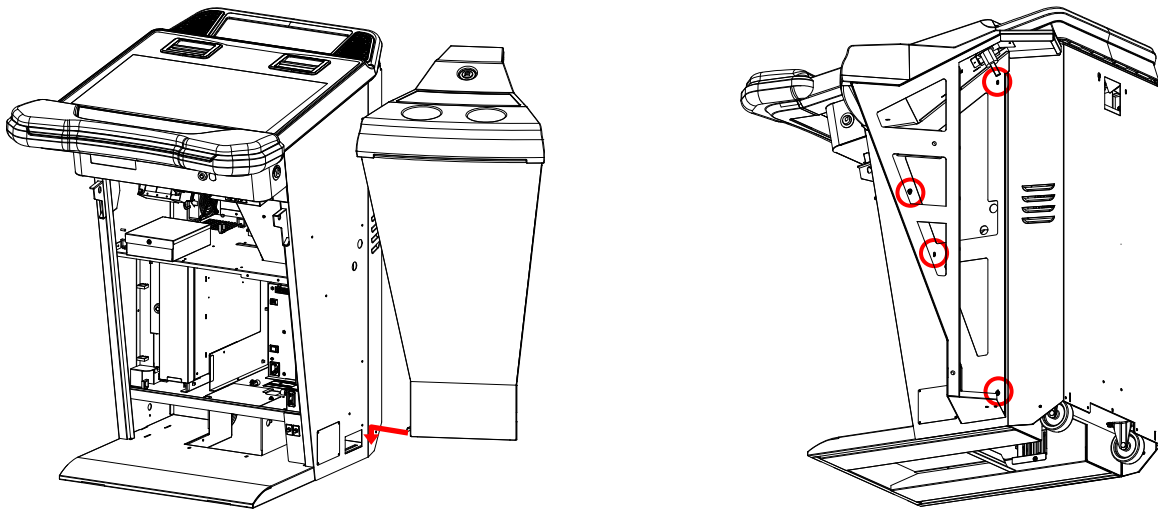

4. Unplug the [BL] connector connected to the inside of the station. Push inside the Station the [BLR] and [OPW] connectors located inside each Spacer Unit, through the opening on the lateral side, and connect them to the [BL] and [OPW] connectors of the Station.

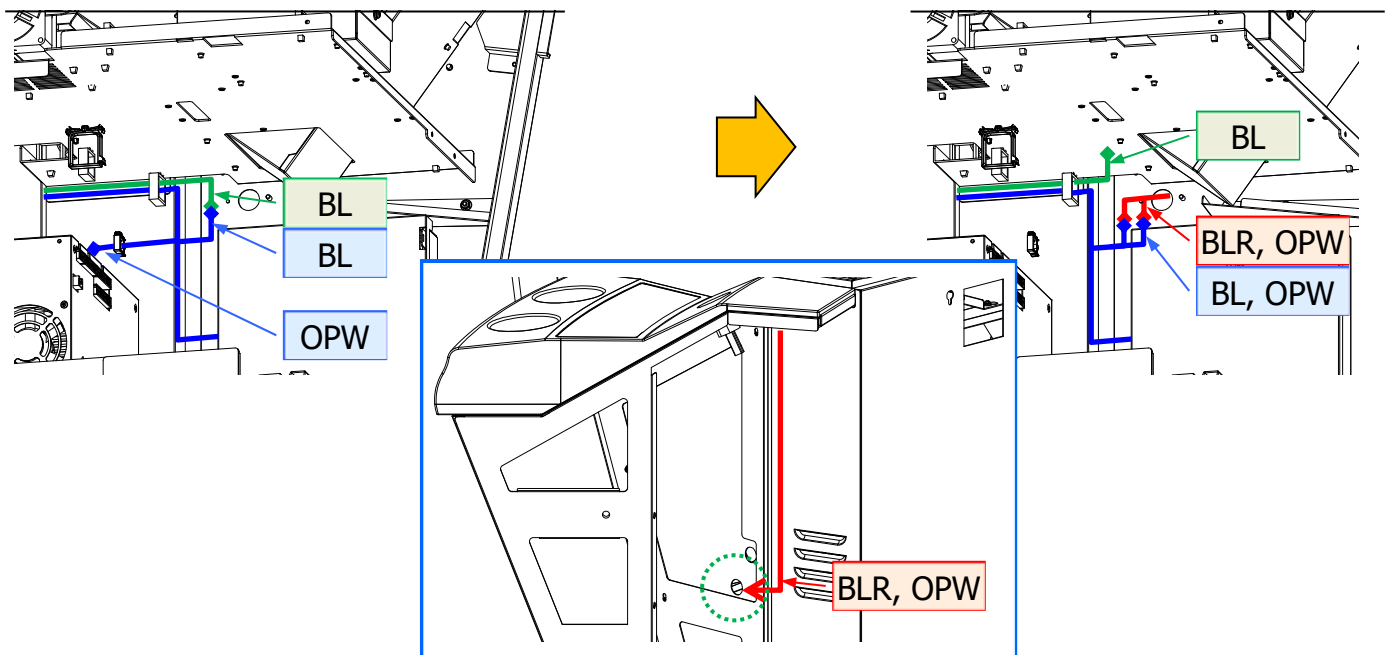

3. 2. 2. 2: Installing Other Stations and Connecting to Center Unit

1. Remove 1 screw and detach the Bottom Cover on each station.

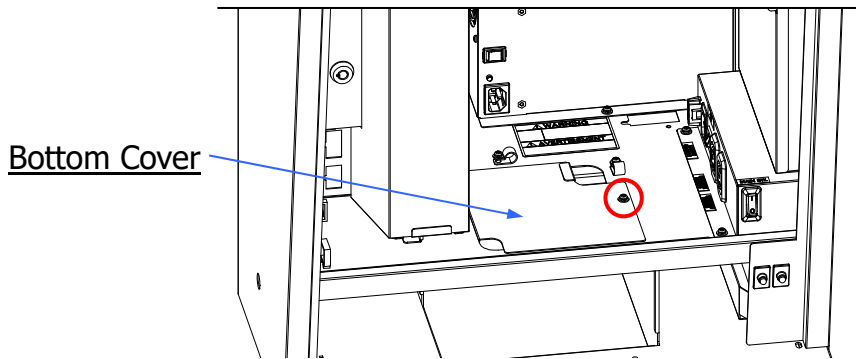

2. Prepare the following Parts.

Parts Name	Qty	Appearance
LAN Cable(for Station: 2.5m)	6	

3. Unlock the Security Cage Front Cover and connect the LAN Cable to the [LAN 2] Port indicated below. Then push the opposite head out of the Station.

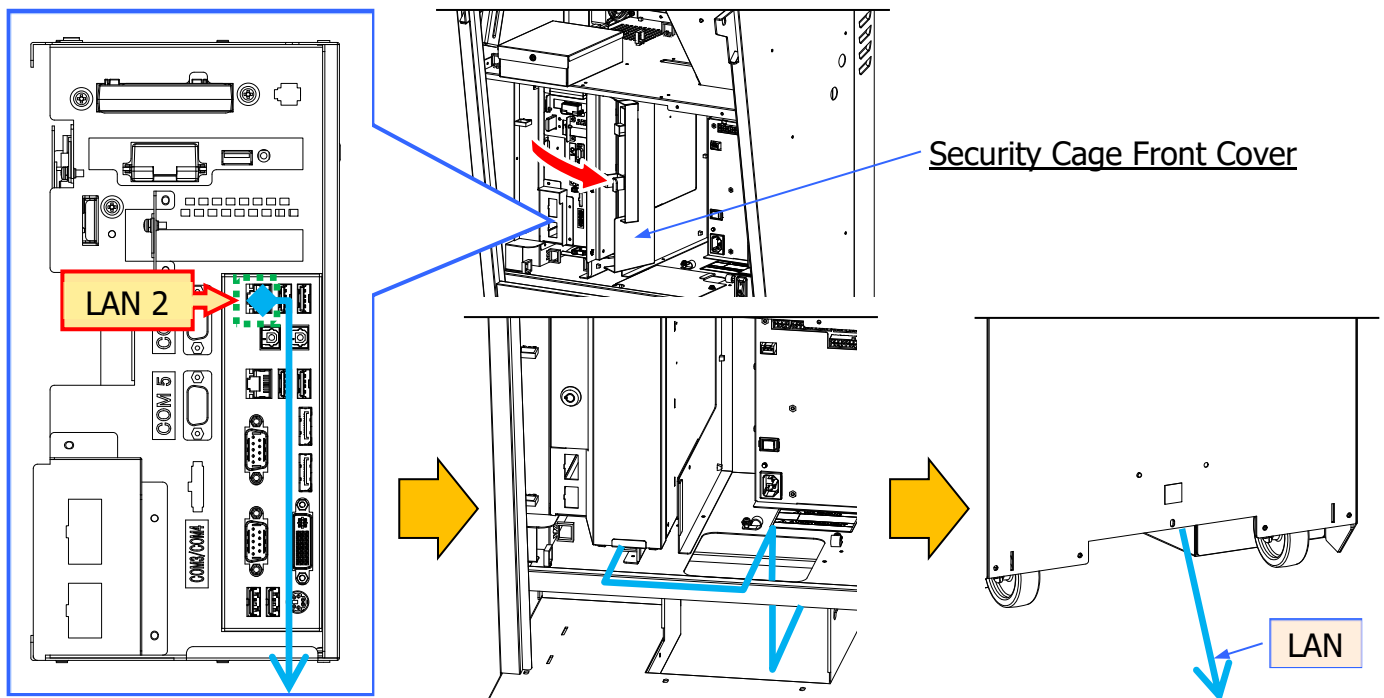

4. Refer to the illustration below, and while connecting the LAN Cable that was pulled out from each Station to the LAN Ports of the Center Unit, arrange the Station Units around the Center Unit. (The [STATION No.x] of each Station Unit is the same as the corresponding [LAN Port No.x]).

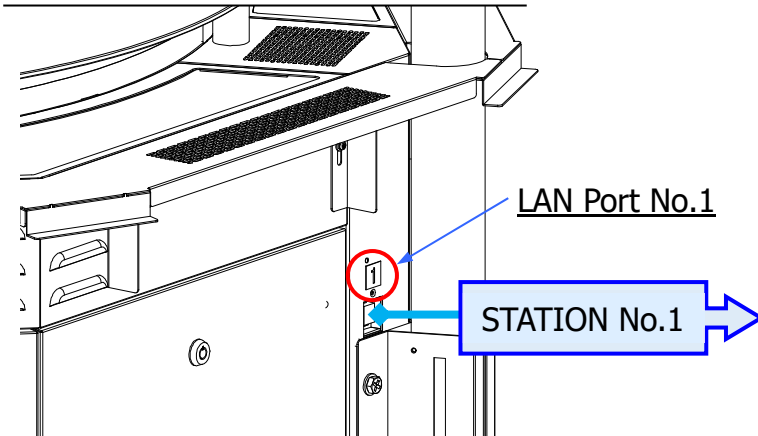

i NOTE: Option-[If using a USB Charger]

Insert the AC Adapter of the AC Cable for the USB Charger, at the bottom of the rear side of the Station.

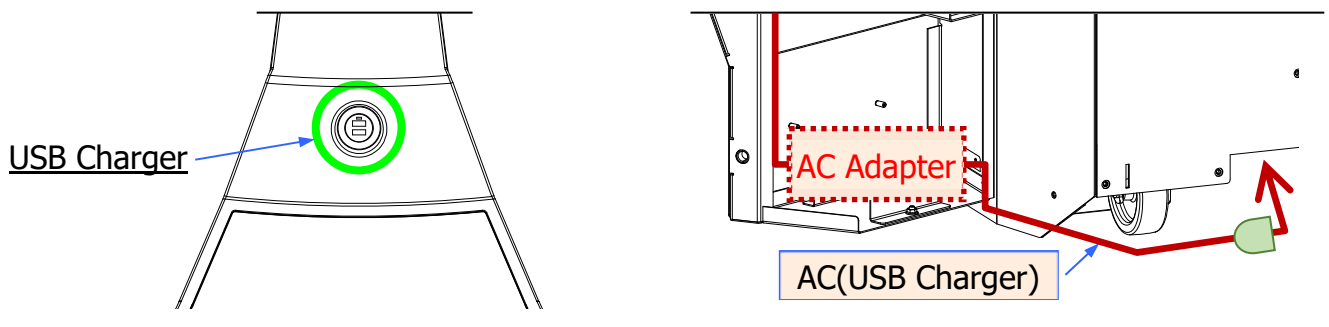

[Station Layout Chart]

s1 = Station **p1** = Pole **c1** = Corner

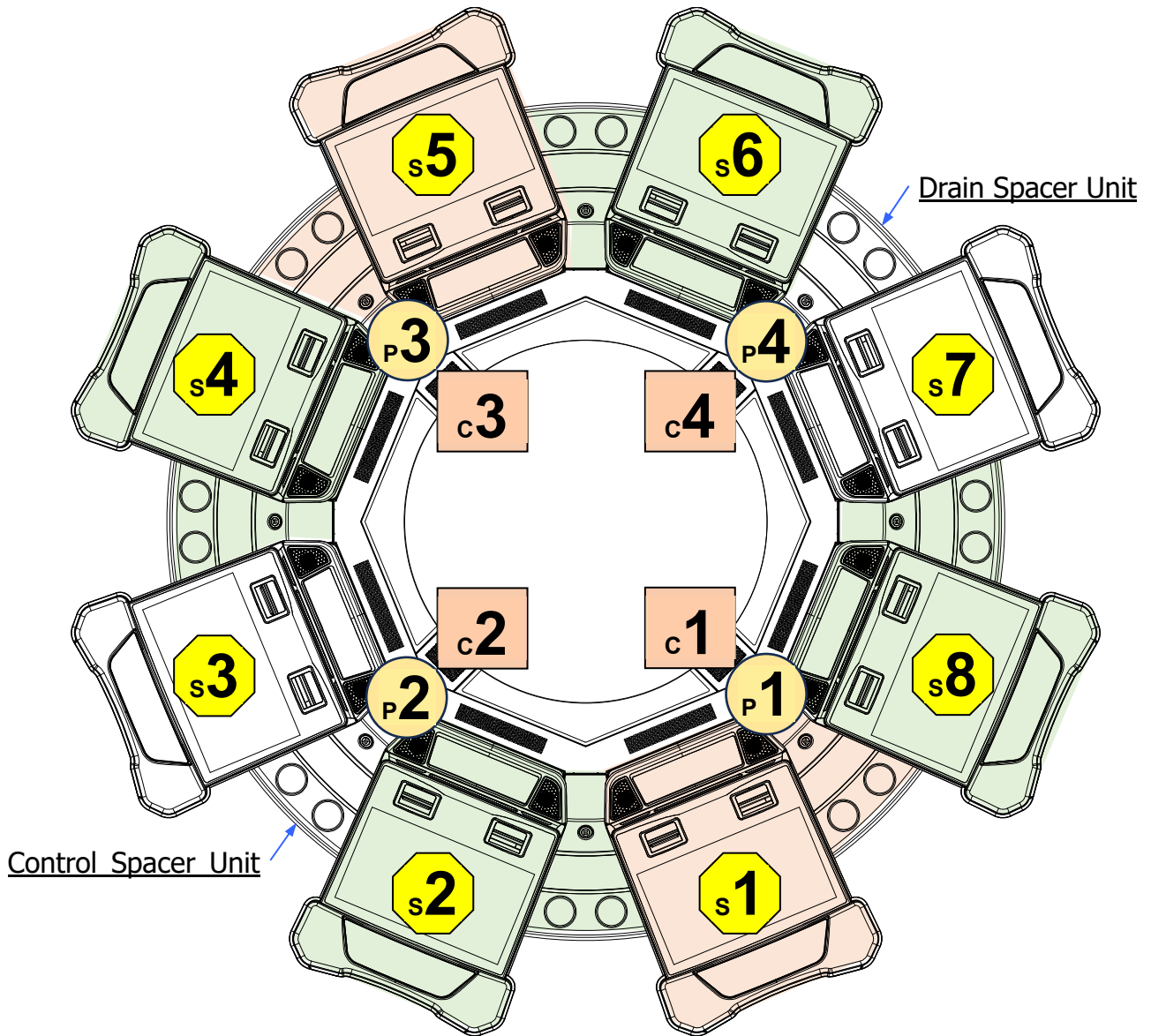

5. Affix each station to the Spacer Unit immediately on the left, by using 2 bolts.

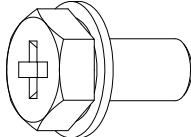
Fasteners		Qty	Appearance
P	HEX UPSET M10 x 20 3P	16	

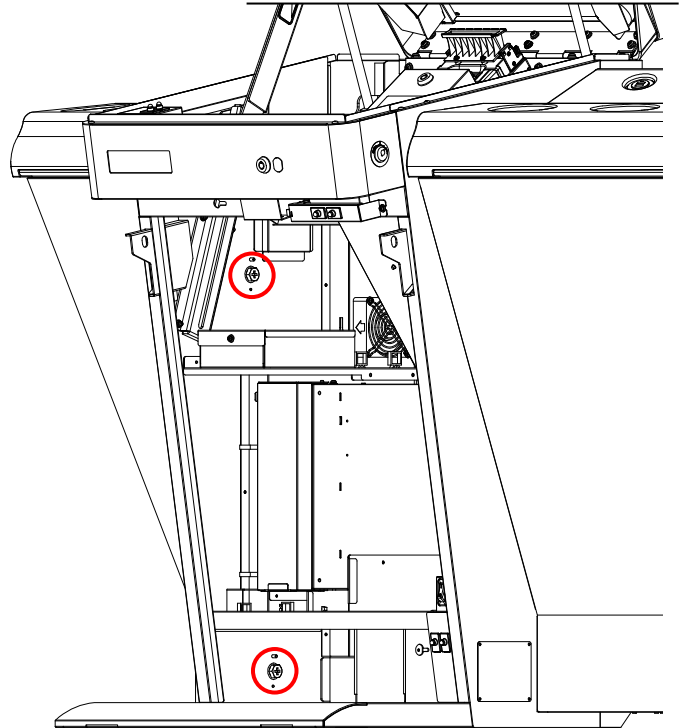

i NOTE: [In case it is planned to extend the number of stations]
 Complete in advance the installation of all the Extension Stations. Connect the [LAN] Cables for Extension Stations use, that were connected to the Switching Hub of the Center Unit (**Refer to 3.2.1.13**), to the Extension Stations (or to the Hub connected to that).

3. 2. 2. 3: Hardware Setting for Station Unit

Hardware Settings are necessary for factory shipped products to be operational. Before commencing with operation, make sure to do the settings explained below.



WARNING!

Electrostatic discharge may damage internal components. When accessing the inside of the Cabinet, take anti-static measures (as wearing anti-static wrist band etc.) before proceeding.



CAUTION!

Hardware Settings must be done by authorized personnel.
Once Hardware Settings are updated, all the Software Meters will be cleared to zero.
Make sure to take note of all necessary Software Meters before updating.

- Location of PCBs -

The PCBs that require setting are shown below inside a frame.

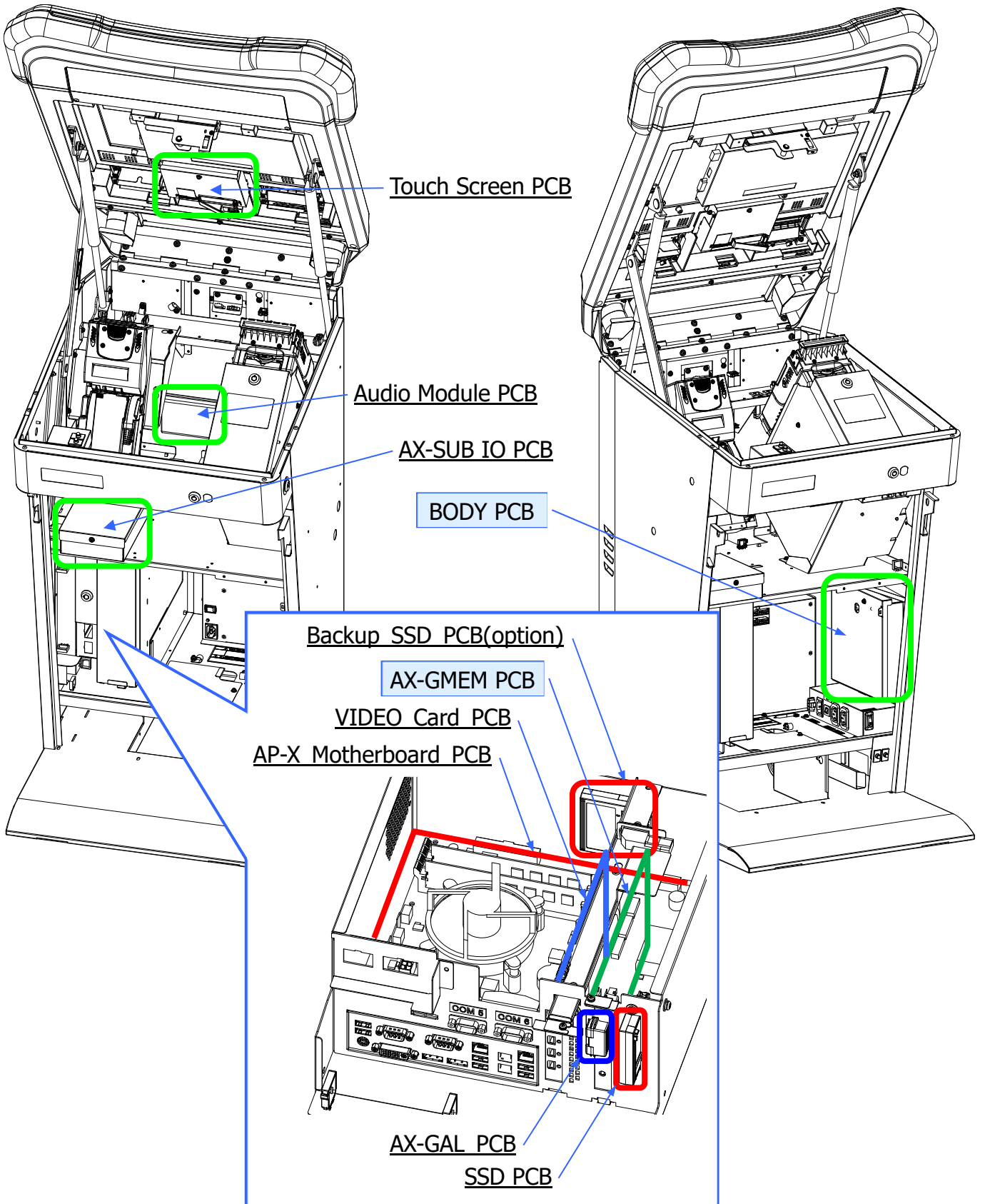

- AX-GMEM PCB -

PCB	Onboard Switch/Jumper	Factory Setting	Setting for Operation	Description
AX-GMEM PCB	S2 (Slide Switch)	Front (Battery OFF)	Back (Battery ON)	The switch for Backup Battery ON-OFF

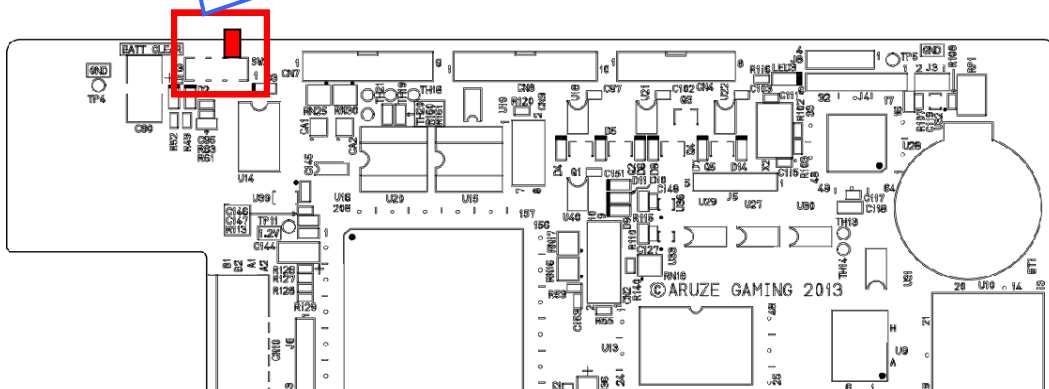
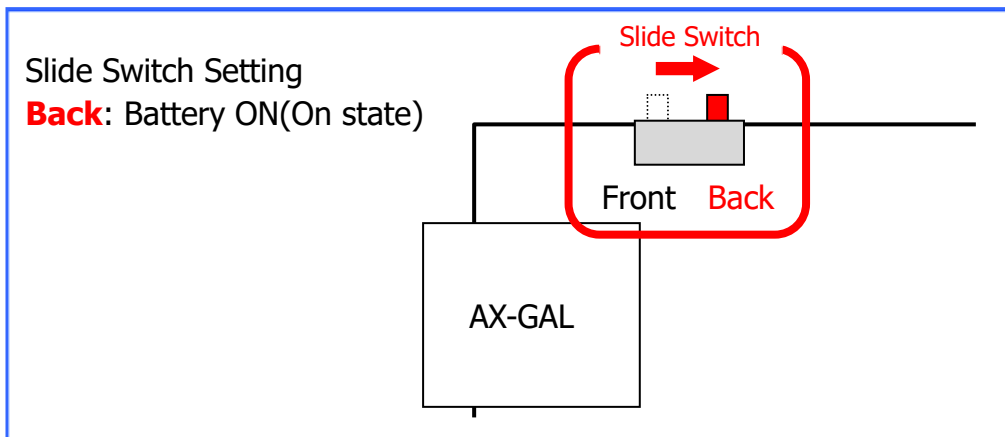
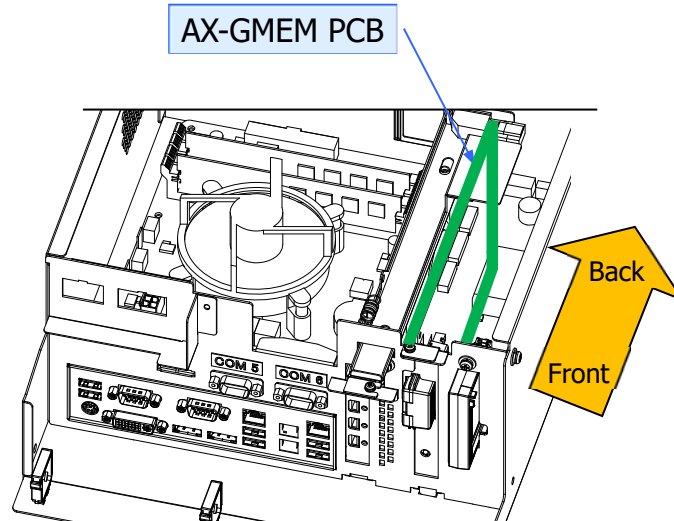

- BODY PCB -

PCB	Onboard Switch/Jumper	Factory Setting	Setting for Operation	Description
BODY PCB	SW2(2 Bit Dip Switch)	All OFF (Invalid)	All ON	The switch for enabling the Backup Battery

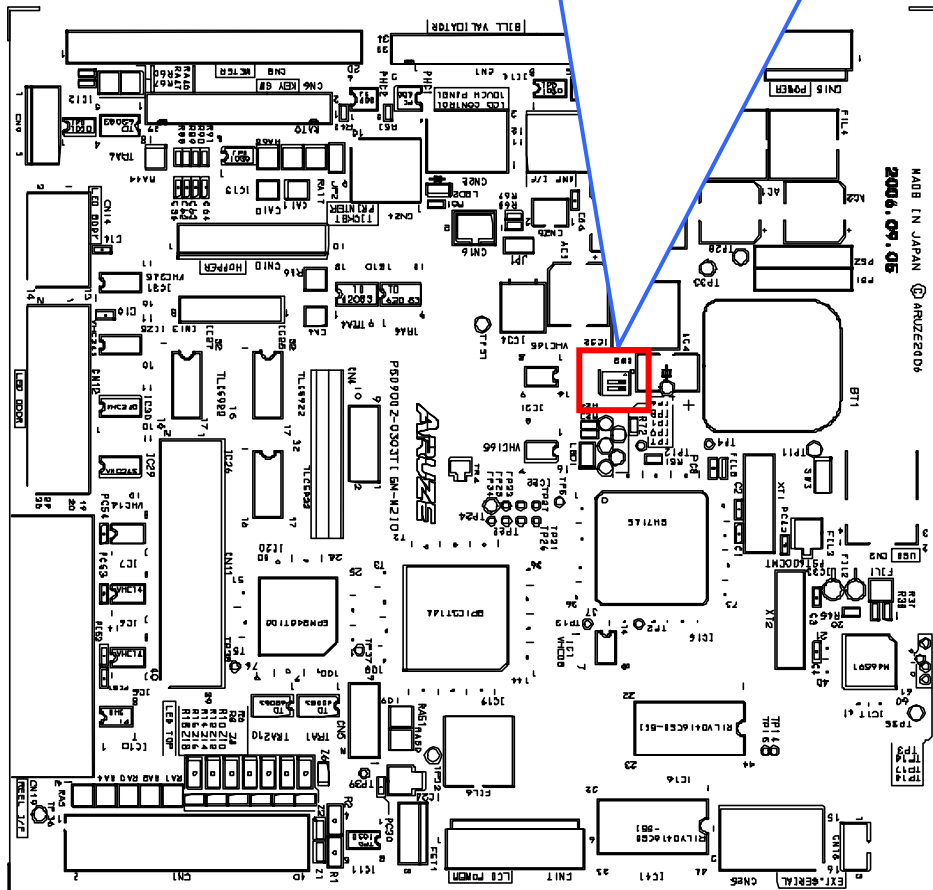
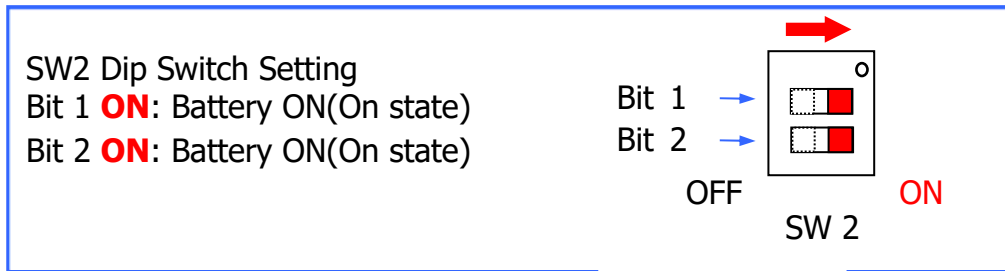
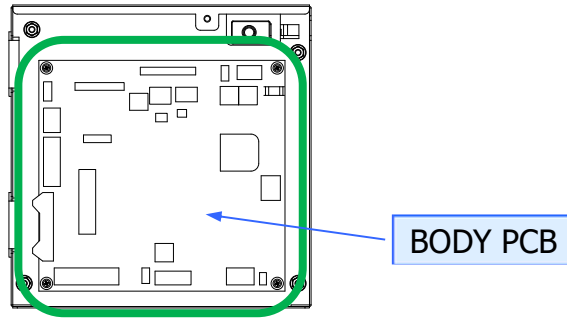

3. 2. 2. 4: Connecting the Stations to the Power Source

1. Make sure that the Power Switch of each Station is set to OFF.

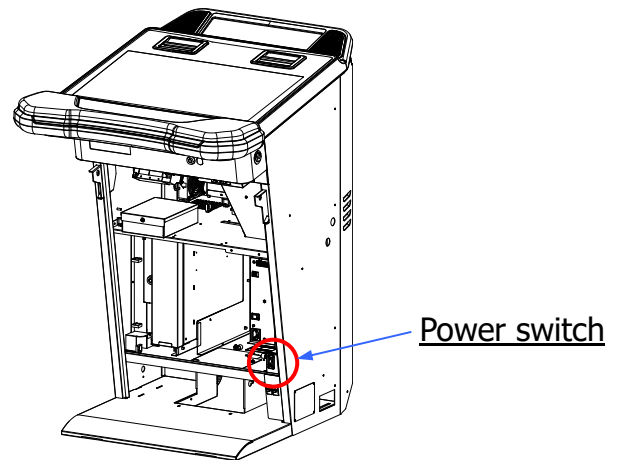

2. Prepare the following Parts.

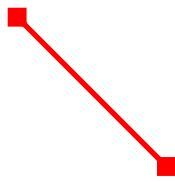
Parts Name	Qty	Appearance
AC Cable(for Station)	8	

3. Connect the Plug-in Unit (AC Base) and the Power receptacle of each station to the AC Cable. If a USB Charger is connected, when installing each Station plug also the AC (USB Charger). Arrange the cables installed so that they will not be an obstacle to the further procedures.

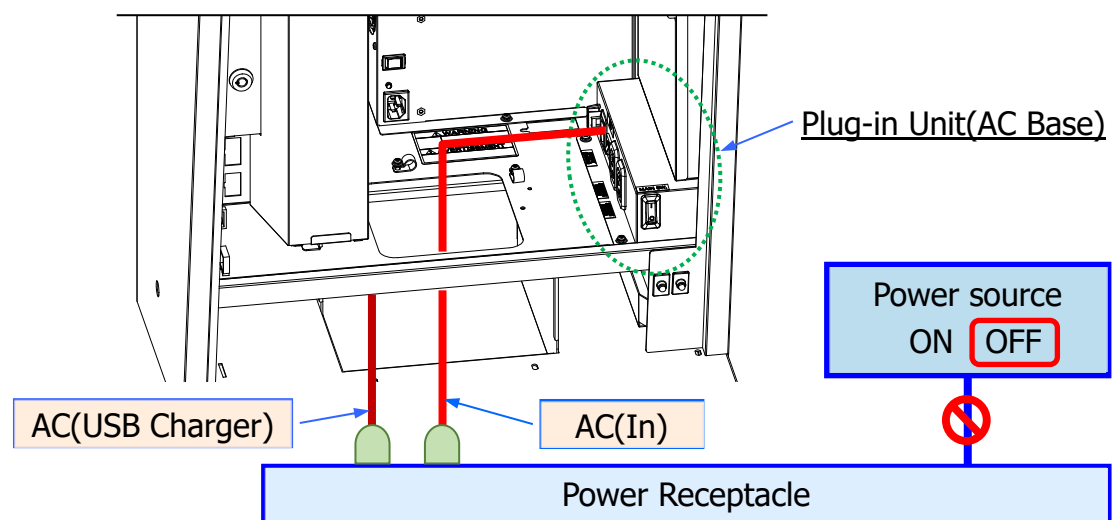

- Return the Bottom Cover and the Bottom Door of each Station to its previous position.

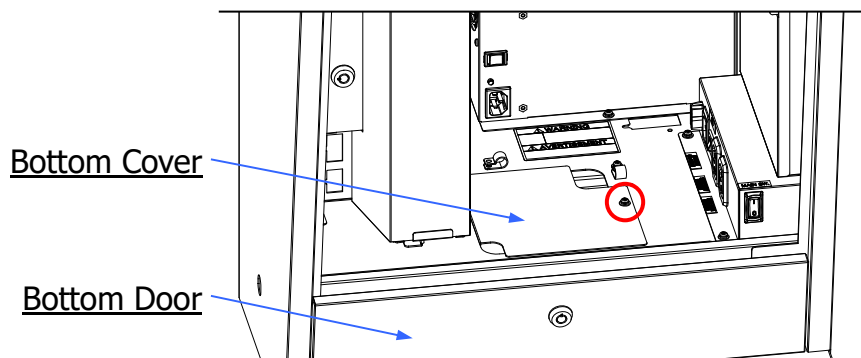

- This completes the connection to the Power Source of each Station.

3. 2. 3: Checking and Setting

i NOTE: Option-[In case it is planned to extend the number of stations]
Continue the procedure after the installation of all the Extension Stations is complete.

Before turning ON the Center Unit and the Stations, check the following;

- All the cable connectors are securely connected and the machine is properly grounded.

3. 2. 3. 1: Preparation to set the Stations

⚠ CAUTION!
Stations power should be OFF at this stage.

i NOTE:
The check for the operation functionality of the Center Unit has already been completed at "**Checking Operation of Center Unit – 1st and 2nd** ", therefore from now it will be performed only the setting of the Stations.

1. First turn ON the power source. The devices directly connected to the power source will boot up.

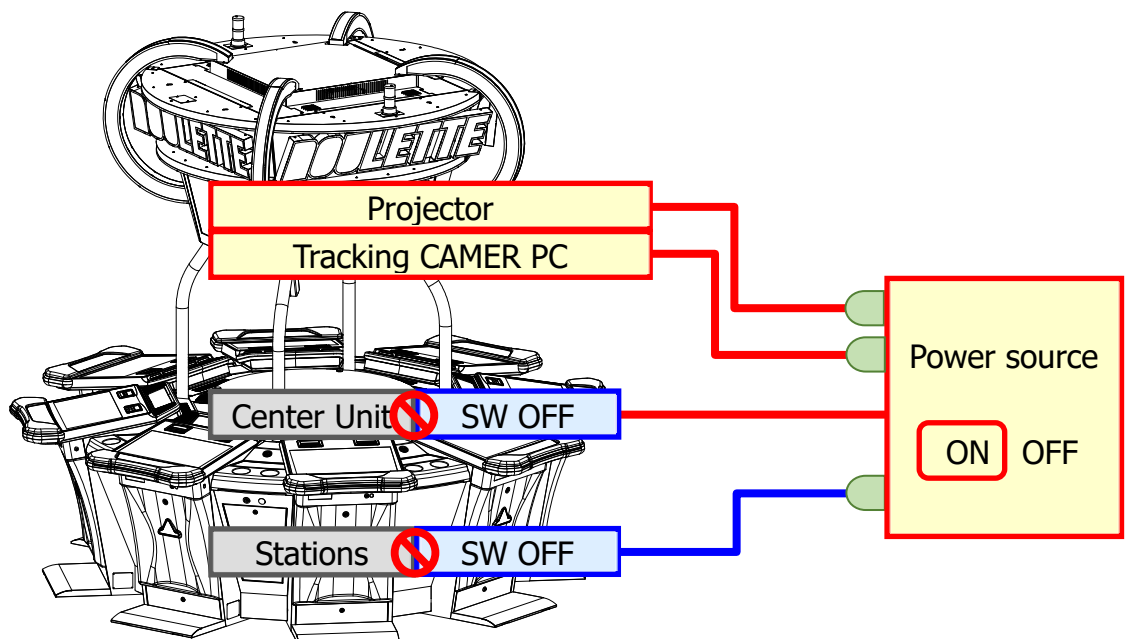

- Turn ON the Power Switches (MAIN SW 1 and MAIN SW 2) of the Control Spacer Unit. Close the Control Spacer Door.

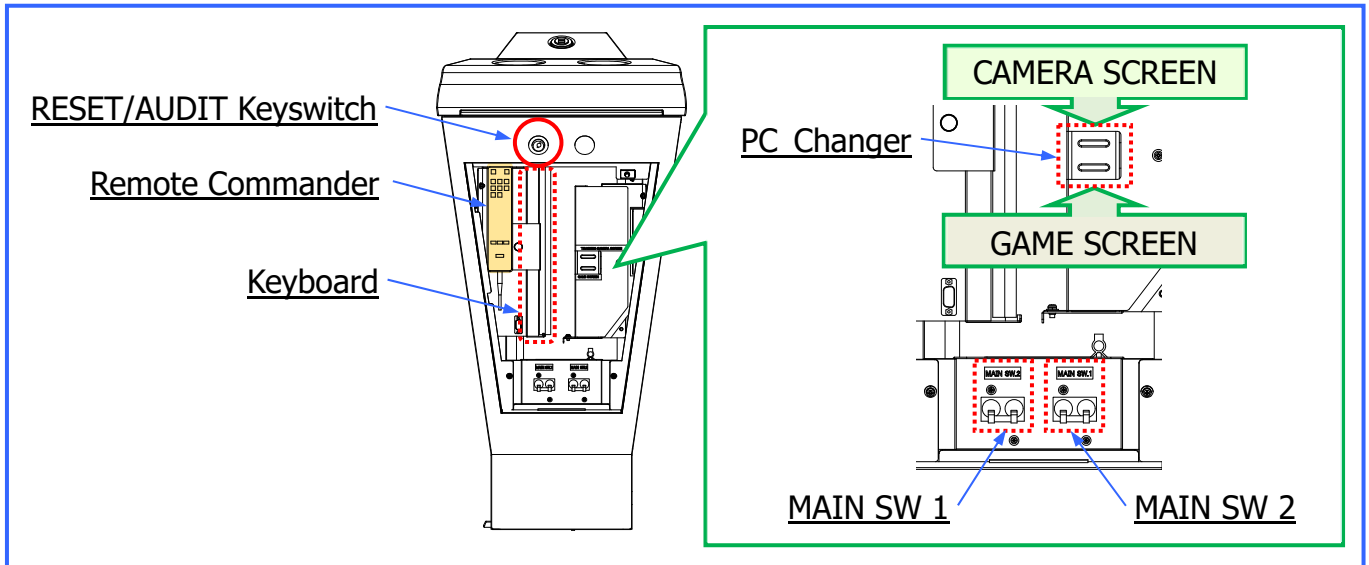

⚠ CAUTION!

- Do not turn ON the 2 Power switches at the same time. Doing so can result in a start-up error of the machine.
- When doing "Power OFF-ON" wait at least 15 seconds before power On.

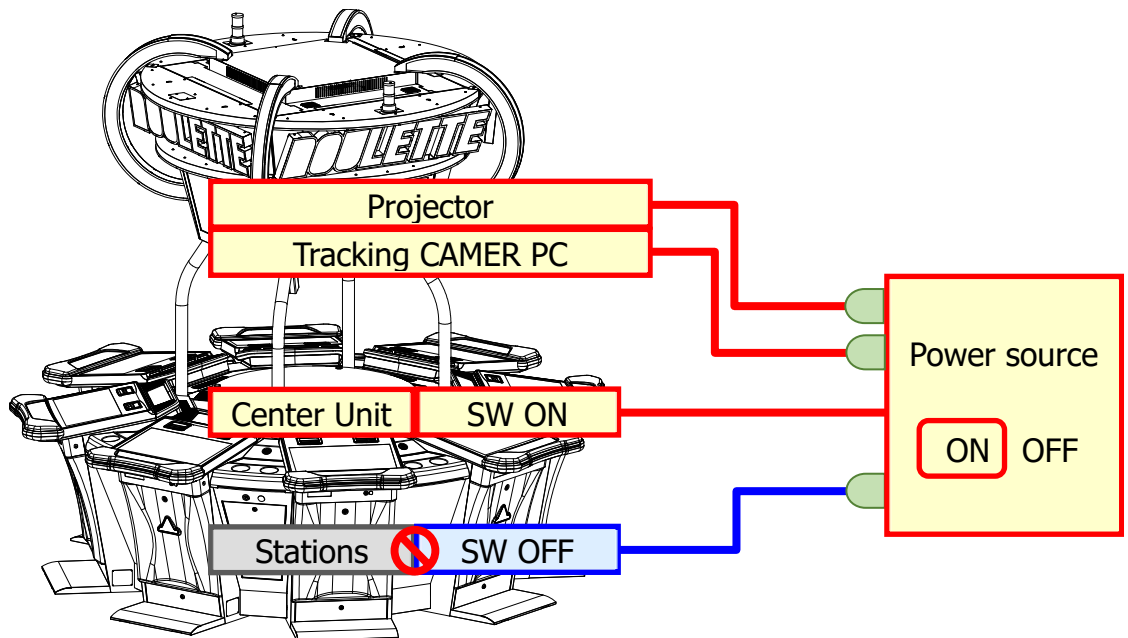

3. 2. 3. 2: Setting operation of Stations

1. Open the Security Cage Front Cover of each of the 8 Stations that are installed around the Center Unit.

CAUTION!

A Station that is booted up for the first time after it was connected to the Center Unit, first needs the setting of the [STATION ID NUMBER].

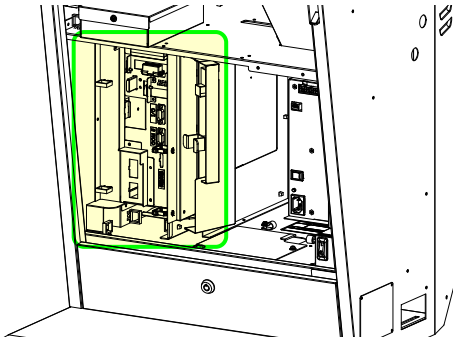

2. Turn ON the Power Switch of only 1 Station.

CAUTION!

- Perform the setting one station at time.
- Do not boot on other stations before the [STATION ID NUMBER] is set.
- When doing "Power OFF-ON" wait at least 15 seconds before power On.
- Do not touch the Touch Screen when [NOW CHECKING] is displayed. This may lead to Touch Screen malfunction.

NOTE:

- If it is necessary to perform the RAM Clear (Memory Clear), refer to **"Memory Clear Procedure"** on Chapter 7 of the SERVICE Manual.
- If an error appears during the POWER UP SELF TEST, the activation of the Machine halts. Refer to OPERATION Manual Chapter 8 **"Error Messages"** to clear it.
- When the machine was shipped, the touch Screens were calibrated. However, if needed, calibrate the touch Screens by referring to our Service Manual.

- ◇ Are there any strange sounds or smells coming from the machine?
- ◇ Test the proper functionality of Sensors, RESET/AUDIT key switches etc.

3. To call the AUDIT mode, turn the key to the AUDIT position, and return it to the neutral position.



4. Refer to "**Version Information**" at Chapter 7 of the OPERATION Manual, to check that the Software version is the same as the Software Version approved for installation.
5. Refer to "**Settings**" on Chapter 5 of the SERVICE Manual to configure the necessary settings.

i NOTE:

IMPORTANT SETTINGS

ONLINE SYSTEM SETTINGS

CELEBRATION SETTINGS

The settings above require a **[reboot]**, therefore it is necessary to pay attention at the order the settings are inputted. Please follow the procedure below.

- ① First, complete only the settings above (listed in green uppercase fonts). (At this point of the installation, set the item "STATION ID NUMBER" to the same value as the [STATION ID NUMBER]. Check the [STATION ID NUMBER] at **[Station Layout Chart]** (Refer to **3.2.2.2**.) When completed, press [RETURN TO PREVIOUS MENU] to return to the TOP MENU and close the [SETTINGS].

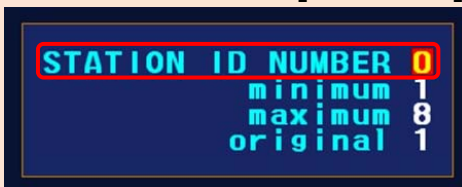

- ② The display will change to the following screen. Press [SAVE and SHUTDOWN] button. The Station Unit will turn into standby shutdown.

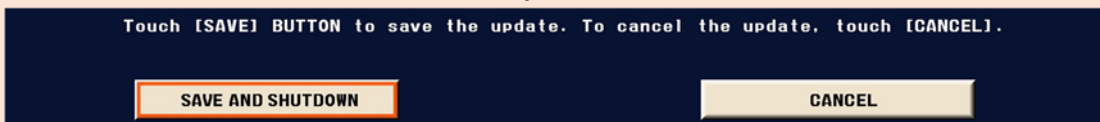

- ※ When the standby shutdown is complete, it is possible to proceed turning Power ON the next station. Repeat the same procedure to set the [STATION ID NUMBER] to each Station, making sure that the numbers do not repeat.
- ③ Turn OFF and ON the Power Switch of the Station Unit and do **[reboot]**. Close the Security Door of the Station Unit. (When doing "Power OFF-ON" wait at least 15 seconds before power On.)
 - ※ Check that the [STATION NO.] at the top of the screen displays the same value set as [STATION ID NUMBER].

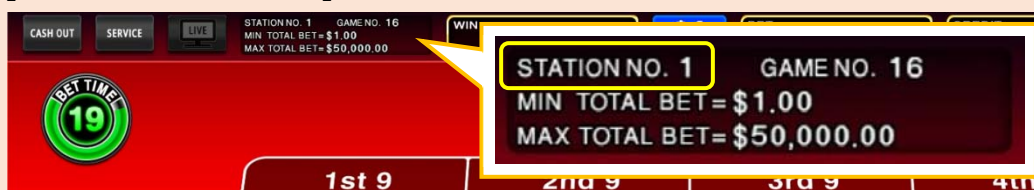

- ④ Open again the AUDIT [SETTINGS] and perform the remaining settings. When completed, press [RETURN TO PREVIOUS MENU] to return to the TOP MENU.

6. Refer to **"Output Test"** at Chapter 5 of the SERVICE Manual, to check if the illuminations are lit correctly.
7. Exit the AUDIT and close the Front Door. Press the GAME RULES button on the Station several times, and check if the BGM plays correctly.

i NOTE: Option-[In case it is planned to extend the number of stations]

Set also the [STATION ID NUMBER] of the additional Stations by following the same procedure and paying attention not to repeat the same number.

If the [maximum] is different from the total number of Stations, including the Expansion Stations, set again [NUMBER OF STATIONS] on the Center Unit. **(Refer to 3.2.1.21)**

Station AUDIT

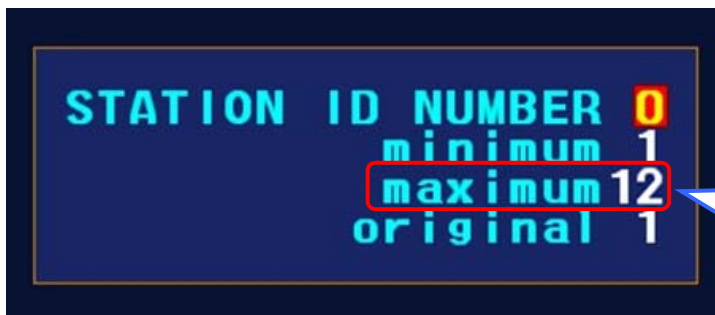

Center Unit AUDIT

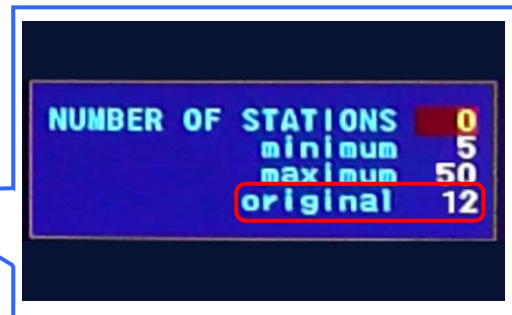

3. 2. 3. 3: Verifying Operation of Whole Machine

1. Verify on each Station that BILLS(NOTES)/Tickets are correctly counted by inserting BILLS(NOTES)/Tickets.
2. Play on each Station 10 games on the installed stations to check if the game normally proceeds.

Appearance of the completed machine.

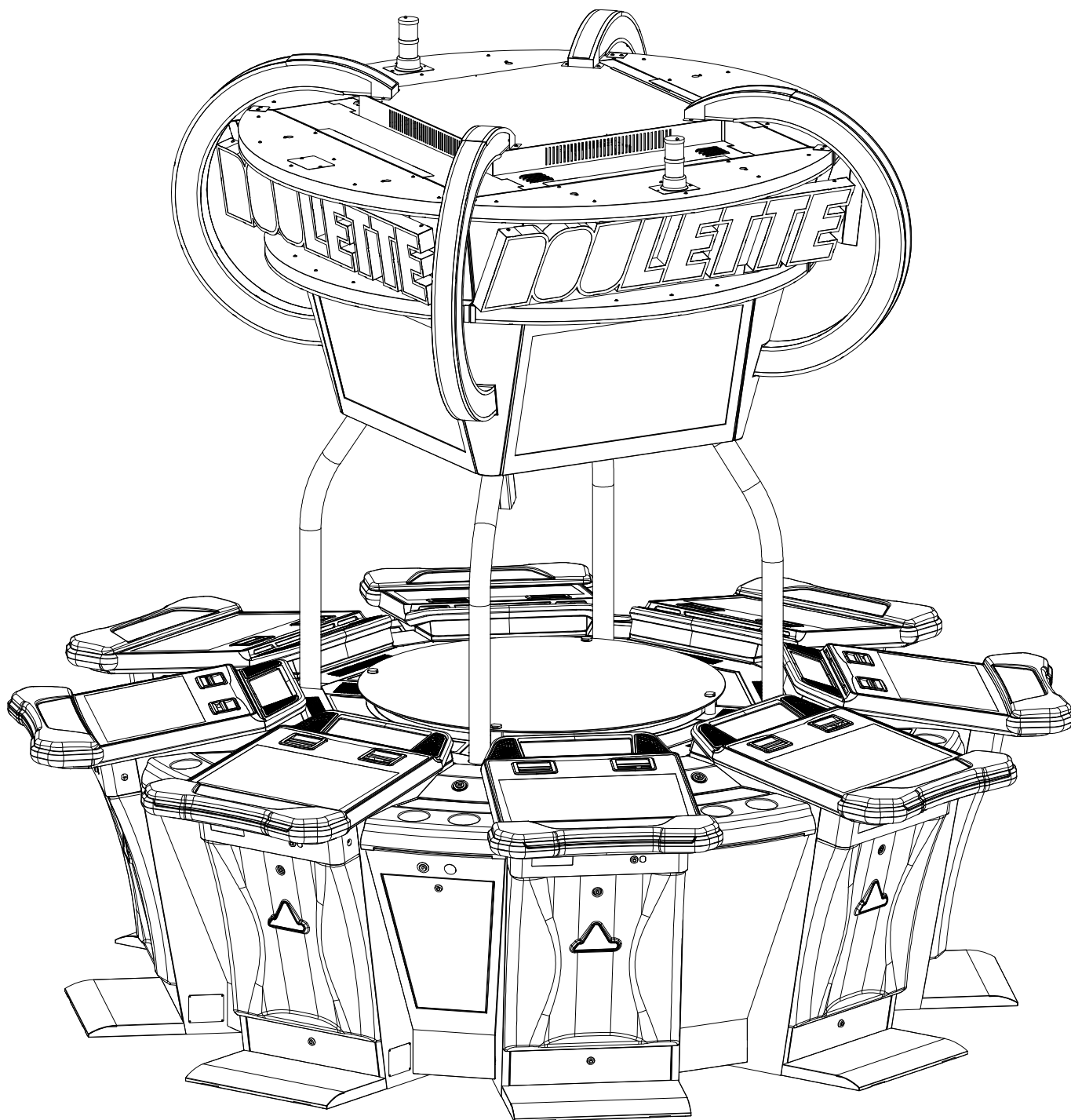



Chapter 4

Machine Specifications

4. 1: Cabinet Code(MODEL#)

Center Unit: ROUX-MS

Station: AXPS01

4. 2: Overall Dimension

	Width	Height	Depth
Whole Machine Including 8pcs Stations layout	3050 mm (120.08")	2735 mm (107.68")	3050 mm (120.08")
Center Unit : Excluding Tower Light	2170 mm (85.43")	2735 mm (107.68")	2170 mm (85.43")
Station : Excluding Back LED Unit : Including Back LED Unit	670 mm (26.38")	972 mm (38.27")	810 mm (31.89") 868 mm (31.17")

4. 3: Weight

Center Unit	600 kg(1322.8 lbs)
Station	90 kg(198.4 lbs)

4. 4: Electrical Specifications

Center Unit: ROUX-MS

Power Requirements

Input Voltage	100 - 120VAC	220 - 240VAC
Input Frequency	50 / 60Hz	50 / 60Hz
Mains Input Current		
EGM Maximum (* Including Service Outlet)	12.9 A	5.3 A
EGM Typical	5.8 A	3.2 A
Power Consumption at Nominal Voltage		
EGM Typical	684 W	647 W
Typical Heat Load	2334 BTU/hr	2208 BTU/hr
Maximum Load Current		
Service Outlet	N/A	N/A
Power Consumption at Nominal Voltage		
EGM Maximum (excluding Service Outlet)	Maximum allowed by PSU	Maximum allowed by PSU

Station: APX-MS

Power Requirements

Input Voltage	100 - 120VAC	220 - 240VAC
Input Frequency	50 / 60Hz	50 / 60Hz
Mains Input Current		
EGM Maximum (* Including Service Outlet)	4.7 A	3.7 A
EGM Typical	1.0 A	0.6 A
Power Consumption at Nominal Voltage		
EGM Typical	119 W	118 W
Typical Heat Load	404 BTU/hr	401 BTU/hr
Maximum Load Current		
Service Outlet	1A x 2	1A x 2
Power Consumption at Nominal Voltage		
EGM Maximum (excluding Service Outlet)	Maximum allowed by PSU	Maximum allowed by PSU

4. 5: Environment

Ambient temperature	0 through 30 degrees C
Ambient humidity	5 through 95% Free from dew condensation

i NOTE:

Please use this machine in an ambient with a temperature below 30°C.

If the ambient temperature exceeds 30°C, the security function of the Projector may put it into a light off status.

To restore the Projector from a light off status, please refer to Trouble Shooting.

4. 6: BILLS Capacity

Maker : Model	Capacity
JCM : UBA / i VIZION / i PRO	500 – 900 BILLS
Cash Code : CASH CODE ONE	600 – 900 BILLS
MEI : CASHFLOW	600 – 1200 BILLS





Customer Technical Support Available 24 hours a day/ 7 days a week

TEL: USA, Canada, Latin America, Asia-Pacific: +1 877 676 7711
Europe, Middle East and Africa: +386 51 305 111
FAX: +386 1 724 77 44
EMAIL: call.center@interblockgaming.com
WEB: www.interblockgaming.com/service

Australia

Interblock Asia & Pacific Pty Ltd

World Square Tower' Suite 4555 Level 45, 680 George Street, Sydney NSW 2000

Canada

Interblock Canada Inc.

#225 - 20316 56 Avenue, Langley, British Columbia, Canada V3A 3Y7

Asia

Interblock Asia Pacific Pty Ltd – Macau Branch

Avenida da Praia Grande, n. 325, Edificio Cheong Fai, 2 andar "B", Macau

USA

Interblock Usa L.C.

6900 S Decatur Blvd. Suite 100, Las Vegas, NV 89118, USA

Latin America

Interblock Spain S.L. – Argentina Branch Regional Office Buenos Aires, Argentina

Esmeralda 1320, Piso 6° Of. B, Buenos Aires 1007, Argentina

Europe

Interblock D.O.O.

Gorenjska cesta 23, 1234 Mengeš, Slovenia, Europe

Japan

G.K. Interblock

TS Tower, 4-12-3 Higashi-Shinagawa, Shinagawa, Tokyo, 140-0002 Japan