

# SHOOT TO WIN CRAPS LUCKY ROLL



## Important notice

### **ATTENTION!**

It is necessary to periodically clean the Wheel Bank, Dice Field etc., according to the prescribed procedure.

It is also strongly recommended to replace the Ball (for Roulette), Clapper (pointer for Big Wheel or Wheel of Wealth) and Dice (for Sic Bo and Craps) if these items are suspected to have developed any abrasions or damage, and to replace these items when their defined usage period has expired.

Furthermore, if abnormal behavior of the machine is observed despite adherence to the prescribed maintenance procedures previously described, please immediately contact the Customer Technical Support or your Sales Representative/Representative Agent. Please notice that failure to adhere to the aforementioned prescribed procedures could result in machine trouble that may not be covered under the conditions of the guarantee.

For any questions regarding maintenance, machine check-up, or the expendable replacement parts, please contact the Customer Technical Support or your Sales Representative/Representative Agent in your area.

### **重要通知**

Wheel Bank、Dice Field 等部件需要按照指定方法定期的进行清理。

除了因为磨损或者损坏进行更换以外，我们也非常建议您在使用了超出规定时间后，定期的更换小球(轮盘)，拍板，骰子(骰宝，花旗骰)等部件。

并且，当进行上述维护步骤时如果游戏机有任何异常时，请迅速与我们的营销人员，服务窗口，供应商取得联系。如果没有按照上述规定的步骤而引起游戏机发生任何的故障问题，不包含在保修之内。请见谅。

关于本公司游戏机的整備，点检以及消化品的交换，如果您有任何疑问，请联系我们的销售人员，服务窗口或者您所在区域的代理商。

## Table of Contents

	Page
<b>General Information</b>	
Introduction _____	1
Technical Support _____	1
Copyright _____	1
<b>Safety Instructions</b>	
Definition of Safety Vocabulary _____	2
Installation _____	3
Replacement of Lithium Batteries _____	3
Disposal of Lithium Batteries _____	3
Environmental Specifications _____	4
Grounding _____	4
Others _____	4
<b>Chapter 1: Major Components</b>	
1. 1 ___ Appearance of Whole Machine _____	<b>1-1</b>
1. 2 ___ Outside View of Center Unit _____	<b>1-2</b>
1. 3 ___ Inside View of Center Unit _____	<b>1-3</b>
1. 4 ___ Outside View of Station _____	<b>1-5</b>
1. 5 ___ Inside View of Station _____	<b>1-6</b>
<b>Chapter 2: Unpacking and Inspection</b>	
2. 1 ___ Unpacking and Inspection _____	<b>2-1</b>
<b>Chapter 3: Installation</b>	
3. 1 ___ Whole Machine Dimension _____	<b>3-1</b>
3. 2 ___ Installing the Machine _____	<b>3-2</b>
3. 2. 1 ___ Center Unit _____	3-4
3. 2. 1. 1 ___ Installing the Center Unit _____	3-4
3. 2. 1. 2 ___ Preparing the Top Sign(CRAPS Top Box) Unit (Installing Tower Light) _____	3-8
3. 2. 1. 3 ___ Installing the Top Sign(CRAPS Top Box) Unit onto the Center Unit _____	3-9
3. 2. 1. 4 ___ Installing Center Unit Gap Cover _____	3-16
3. 2. 1. 5 ___ Connecting the LED Panel Unit to the Center Unit _____	3-19
3. 2. 1. 6 ___ Hardware Setting for Center Unit _____	3-24
3. 2. 1. 7 ___ Connecting the Center Unit to the Power Source _____	3-28
3. 2. 1. 8 ___ Preparation to install the Stations _____	3-30
3. 2. 1. 9 ___ Attaching the Pow Switch and HUB Spacer Unit and the Control Spacer Unit _____	3-34

---

3. 2. 1. 10	___ Installing the Control Spacer Unit to Center Unit _____	3-40
3. 2. 1. 11	___ Installing the Pow Switch and HUB Spacer Unit to Center Unit _____	3-44
3. 2. 1. 12	___ Checking Operation of the Center Unit _____	3-49
3. 2. 2	___ Stations _____	3-55
3. 2. 2. 1	___ Attaching the Spacer Units for the other Stations _____	3-55
3. 2. 2. 2	___ Installing Other Stations and Connecting to Center Unit _____	3-57
3. 2. 2. 3	___ Hardware Setting for Station Unit _____	3-65
3. 2. 2. 4	___ Connecting the Stations to the Power Source _____	3-69
3. 2. 3	___ Checking and Setting _____	3-71
3. 2. 3. 1	___ Preparation to set the Stations _____	3-71
3. 2. 3. 2	___ Setting operation of Stations _____	3-73
3. 2. 3. 3	___ Verifying Operation of Whole Machine _____	3-77

#### **Chapter 4: Machine Specifications**

<b>4. 1</b>	<b>___ Cabinet Code(MODEL#) _____</b>	<b>4-1</b>
<b>4. 2</b>	<b>___ Overall Dimension _____</b>	<b>4-1</b>
<b>4. 3</b>	<b>___ Weight _____</b>	<b>4-1</b>
<b>4. 4</b>	<b>___ Electrical Specifications _____</b>	<b>4-2</b>
<b>4. 5</b>	<b>___ Environment _____</b>	<b>4-3</b>
<b>4. 6</b>	<b>___ Bills Capacity _____</b>	<b>4-3</b>

## General Information

---

### Introduction

This manual is intended to provide information regarding machine operation for operators, owners, and qualified maintenance/service personnel.

It is strongly recommended that this manual be read thoroughly before starting up the machine. Please keep this manual at hand to be used whenever necessary.

### Technical Support

INTERBLOCK Luxury Gaming Products d.d., INTERBLOCK ASIA PACIFIC Pty Ltd, INTERBLOCK CASINO PRODUCTS CANADA Inc., INTERBLOCK ASIA PACIFIC Pty Ltd, INTERBLOCK USA L.C. are all dedicated to providing high quality service and maintenance. Please feel free to contact your local distributor office at any time. (See back page for contact listings)

### Copyright

©2024 Interblock d.o.o. All rights reserved.

The information in this document is confidential. Reproduction in whole or in part on any medium without the express permission of Interblock d.d. is strictly prohibited.

This manual may be subject to change without prior notice.

## Safety Instructions

### Definition of Safety Vocabulary

The words DANGER, WARNING, and CAUTION are used in this manual to indicate hazard levels.

#### **DANGER!**

The DANGER mark warns of immediate hazards, which WILL result in severe personnel injury or death.

#### **WARNING!**

The WARNING mark warns of immediate hazards, which may result in severe personnel injury or death.

#### **CAUTION!**

The CAUTION mark warns of hazards or unsafe practices, which may result in minor personnel injury or product/property damage.

#### **CALL SERVICE IMMEDIATERY!**

This message implies that the operator is recommended to contact the Customer Technical Support. (See back page for contact listings.)

#### **NOTE:**

The NOTE mark brings to attention important operation points.

## Installation

### **WARNING!**

To prevent an accident or a fire;

- ◇ Install the machine on flat, stable, well-constructed floor.
- ◇ Keep the machine away from direct sunlight.
- ◇ Keep the machine away from dust.
- ◇ Keep the machine away from water and other liquids.
- ◇ Do not install the machine outdoors.
- ◇ Keep the machine away from vibration.
- ◇ Keep the machine away from dangerous articles.
- ◇ Keep the machine away from disaster prevention facilities. (e.g. emergency exits/stairs, fire hydrants, fire extinguishers)
- ◇ **If the Projector is installed, please use the machine in an ambient with a temperature below 30°C. If the ambient temperature exceeds 30°C, the security function of the Projector may put it into a light off status.**

## Replacement of Lithium Batteries

### **CAUTION!**

Risk of Explosion.

When exchanging the lithium batteries, use an officially provided lithium battery.

Risk of Explosion if lithium battery is Replaced by an Incorrect type.

## Disposal of Lithium Batteries

### **WARNING!**

Risk of Injury or Fire.

Proper care is necessary with the disposal of lithium batteries. Improper disposal may result in the heating or ignition of the batteries, which may cause personal injury or fire. CR Coin Lithium Batteries contain Perchlorate material – special handling may apply.

Lithium batteries contain flammable substances (e.g. lithium metal and organic solvents). Electric power may remain in used batteries. Wrap the + and – electrodes with nonconductive material to prevent short-circuiting.

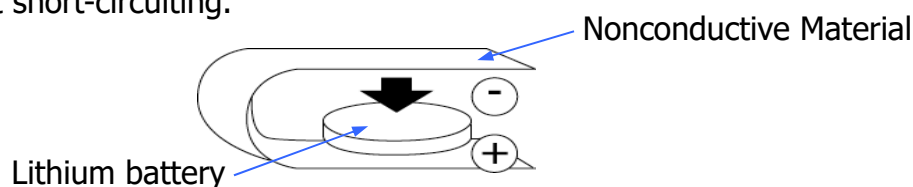

## Environmental Specifications

Refer to "**Machine Specifications**".

## Grounding

The machine must be grounded to prevent current leakage.



### **WARNING!**

Risk of Electric Shock. The warranty is not valid for accidents (including failures) caused by improper grounding.

## Others



### **WARNING!**

The machine should never be modified in any way.

Modification may cause accident or failure.

The warranty is not valid for accidents (including failures) caused by modification.

- ◇ Only qualified personnel shall assemble, install, maintain, inspect, and/or enact any troubleshooting measures to the machine.
- ◇ Do not sit, stand or put heavy objects on the machine. A dented machine may cause malfunctioning.
- ◇ When smoke and/or an unknown malfunction is detected, immediately turn off the power switches and then turn off the power source breakers in that order.
- ◇ Before servicing the machine, turn off the power switches to prevent electricity-related accidents and hazards.
- ◇ Never use chemical dusters, paint thinner, benzene, alcohol, or synthetic detergent for cleaning the machine. Damage may be caused to the machine surface.
- ◇ Electrostatic discharges may damage the internal components of the machine. Anti-static measures (e.g. touching a metal door knob, use of non-static gloves) are necessary when accessing the inside of the cabinet.
- ◇ This machine is for use in commercial areas. Use in residential areas is prohibited.

# Chapter 1

## Major Components

### 1. 1: Appearance of Whole Machine

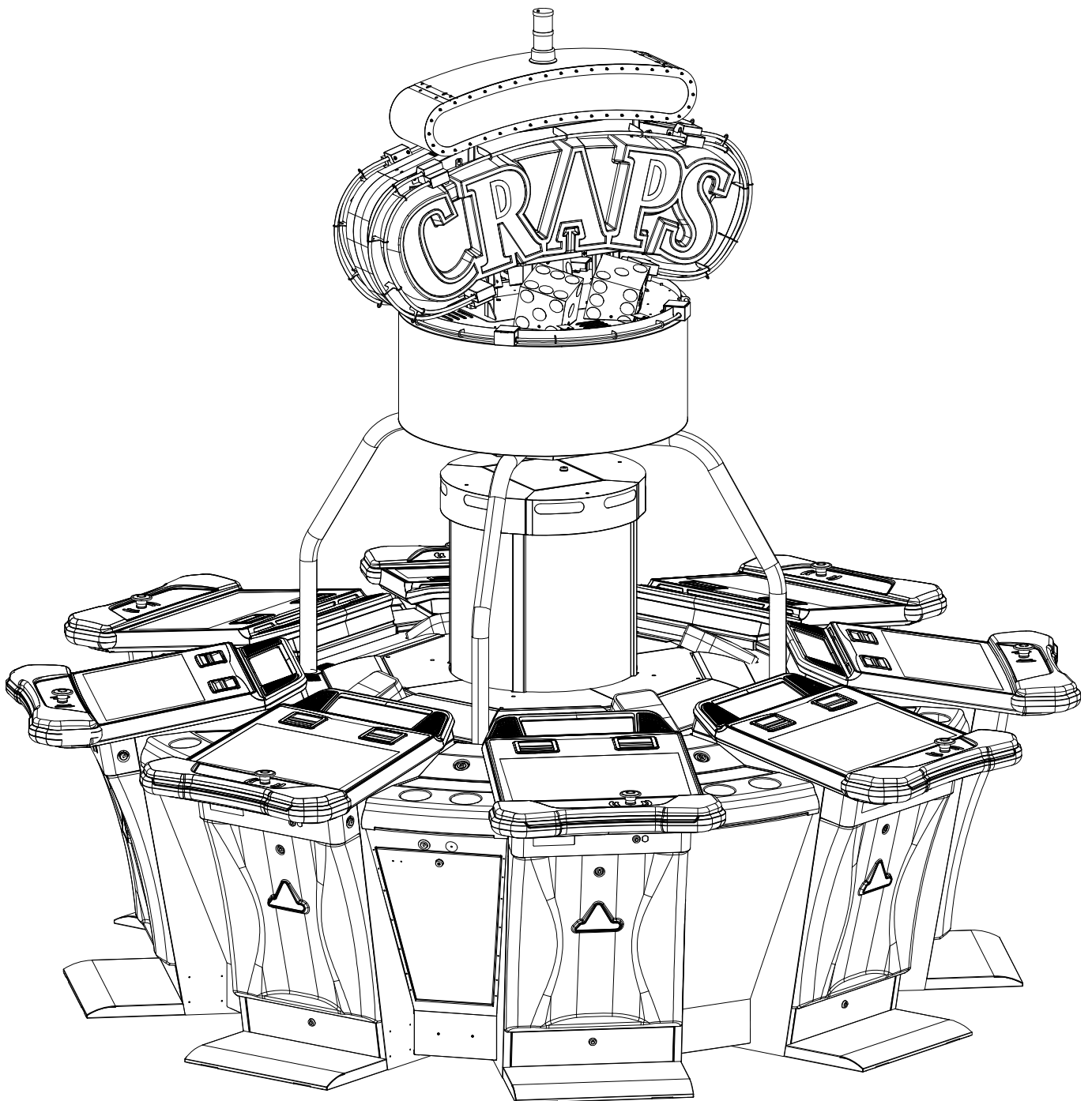

## 1. 2: Outside View of Center Unit

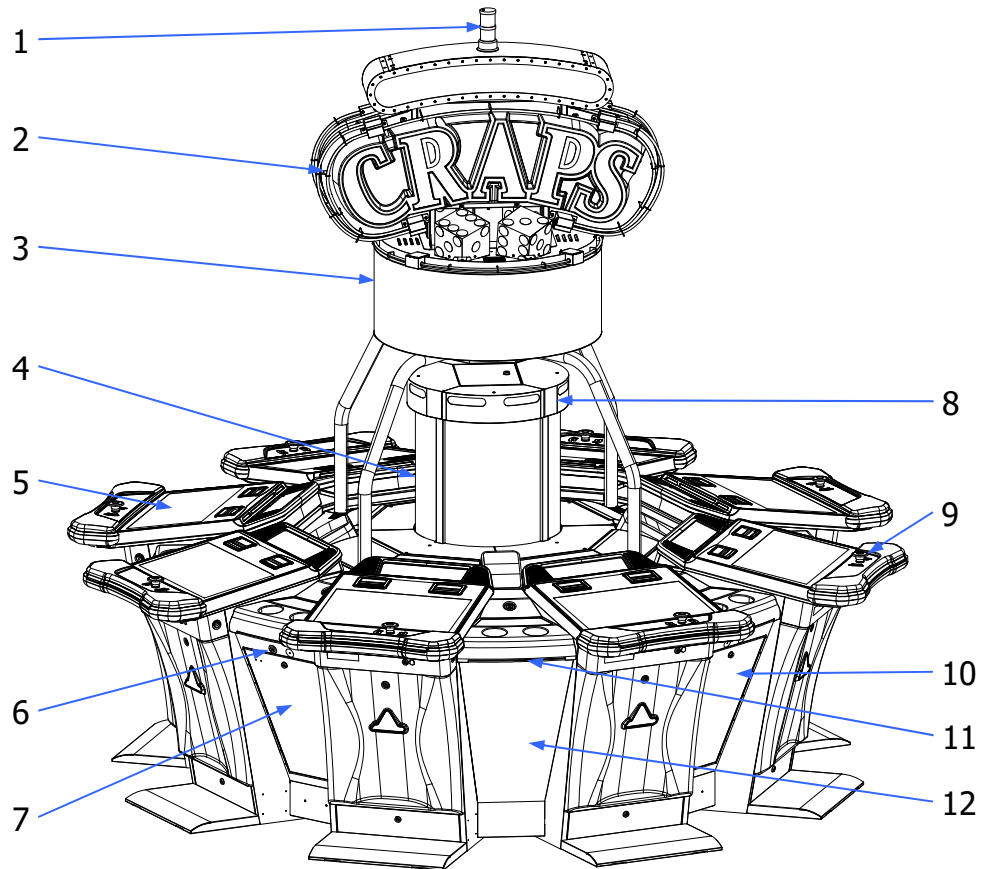

- |                                 |                                    |
|---------------------------------|------------------------------------|
| 1. Tower Light(Optional)        | 8. Head(Field Area) Cover LED      |
| 2. Top Sign(CRAPS Top Box) Unit | 9. Shooter Button                  |
| 3. LED Panel Unit               | 10. Pow Switch and HUB Spacer Door |
| 4. Center Unit                  | 11. Spacer LED                     |
| 5. Station                      | 12. Spacer Unit                    |
| 6. RESET/AUDIT Key switch       |                                    |
| 7. Control Spacer Door          |                                    |

### 1. 3: Inside View of Center Unit

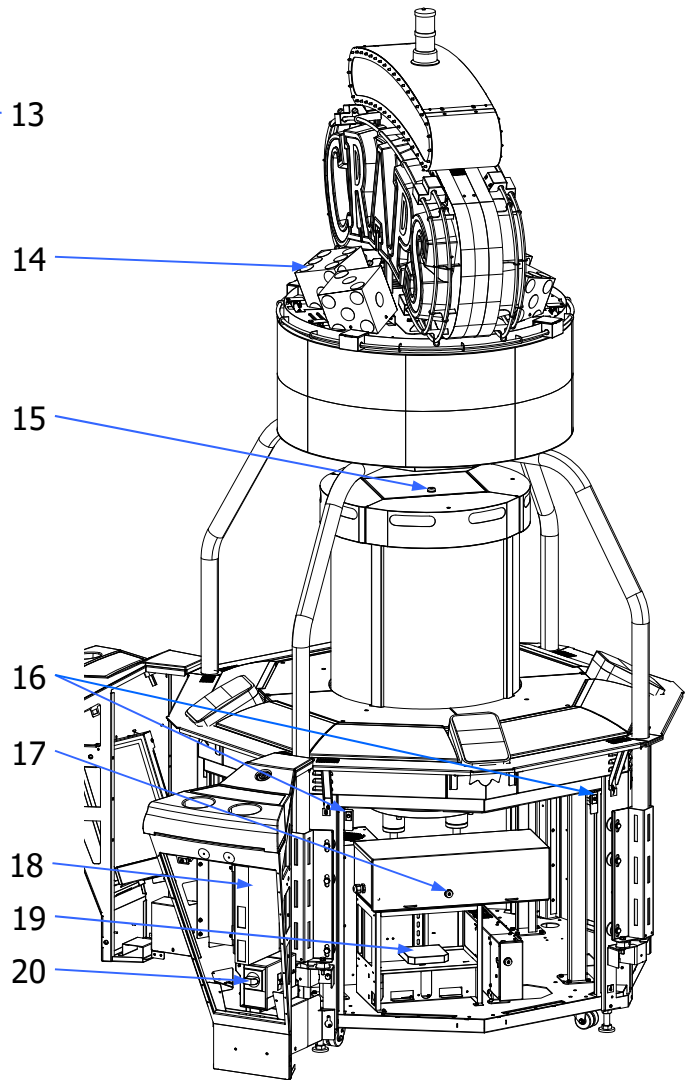
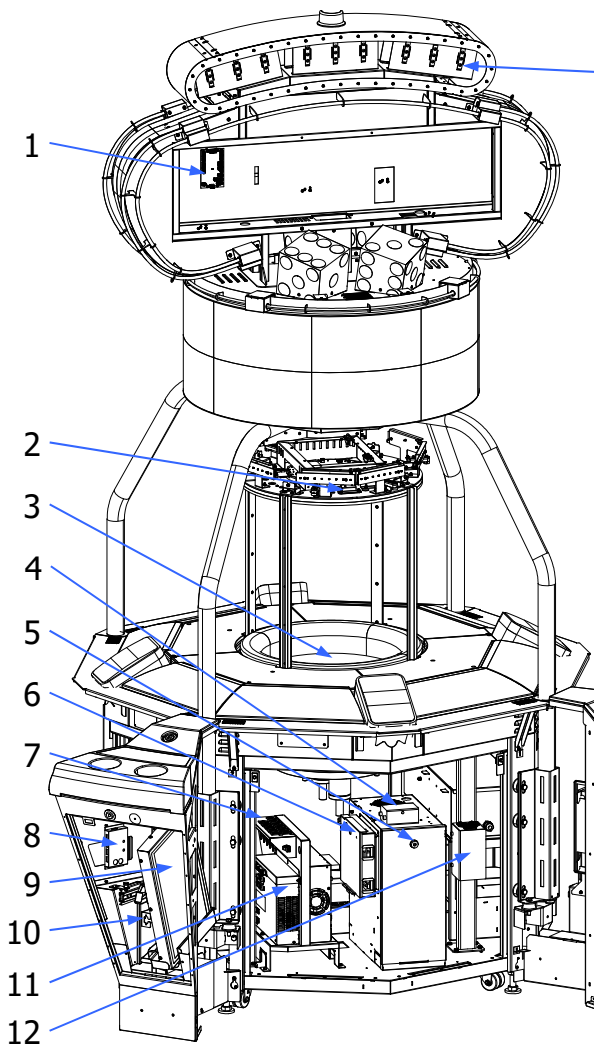

1. Top LED Driver Module (PN5010)
2. Network Camera
3. Dice Field
4. Tinker Board Unit
5. Security Cage Door Lock
6. IO Case Unit
7. Breaker Unit
8. 2CH KVM Switch
9. LCD Control Pad
10. GAT3(D SUB) Connector(Optional)
11. Main Power Unit
12. Power Relay Unit

13. Light Guide Plate
14. Top Table Dice Unit
15. Head Door Lock
16. Center Door Switches.
17. Driver Case Cover Lock
18. Switching HUB
19. Audio Module
20. Main Power Switch

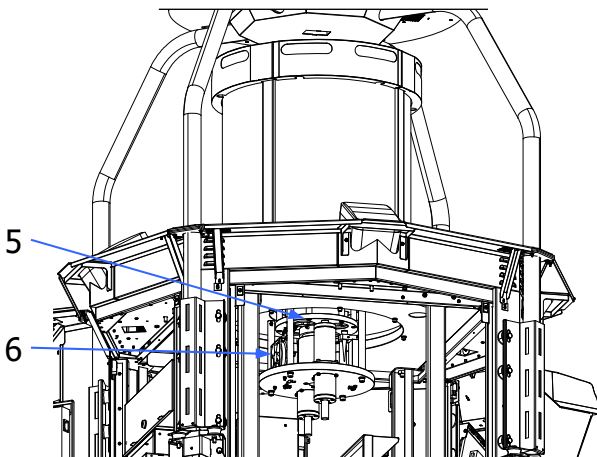
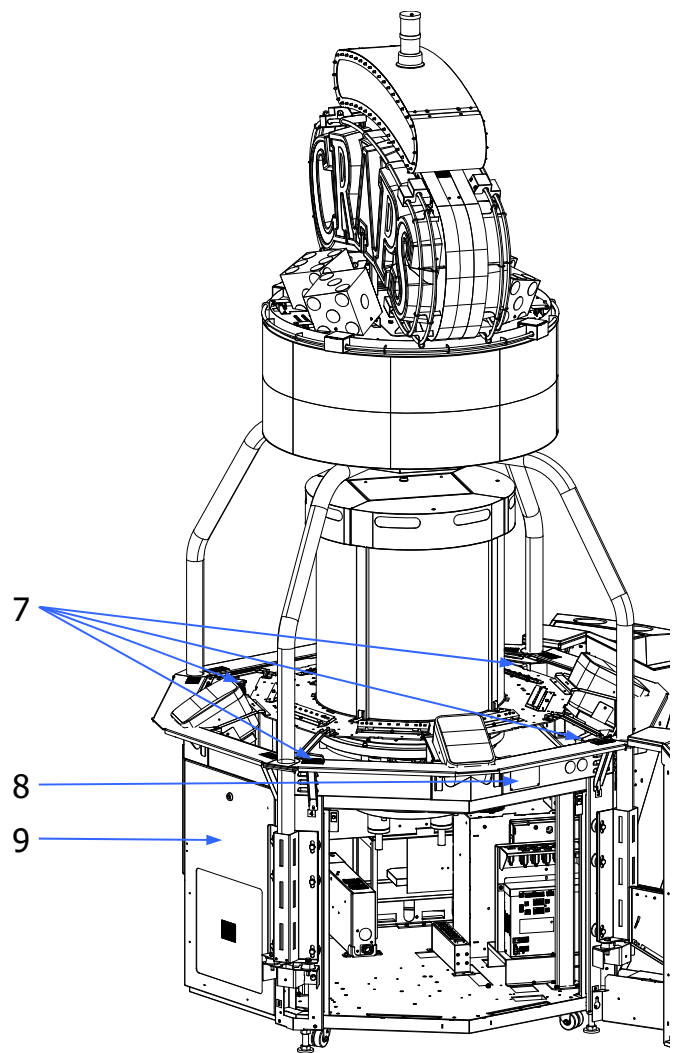
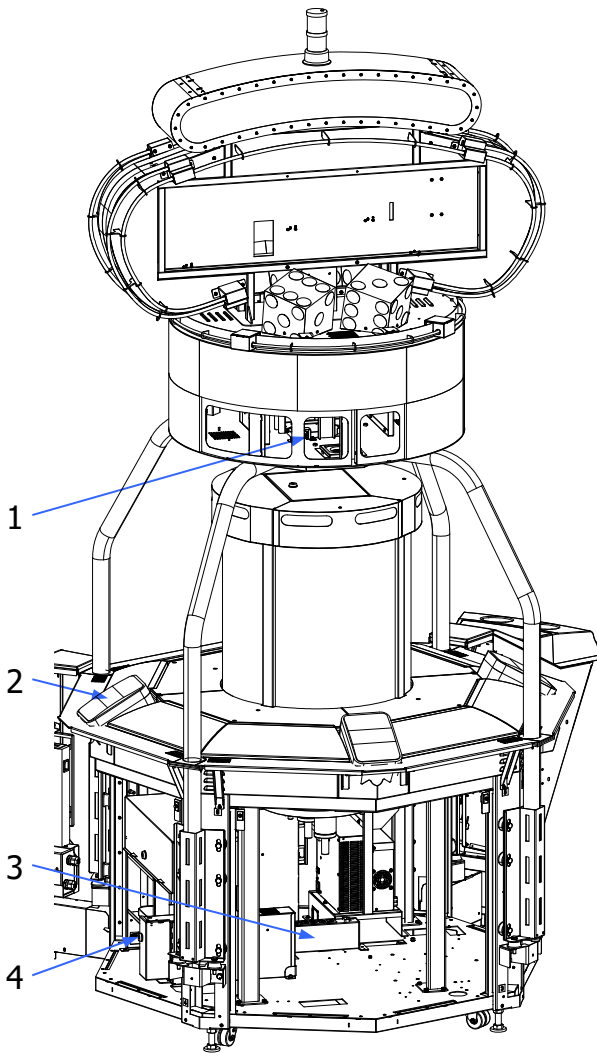

1. AC Base: INLET(for Signage Unit)
2. Speakers
3. Power Distribution Unit
4. ETD PC Case Door Lock
5. DICE Generator Unit(Actuator)
6. DICE Generator Fan

7. Fans(Cabinet Fan)
8. ID Plate
9. Center Unit Doors

### 1. 4: Outside View of Station

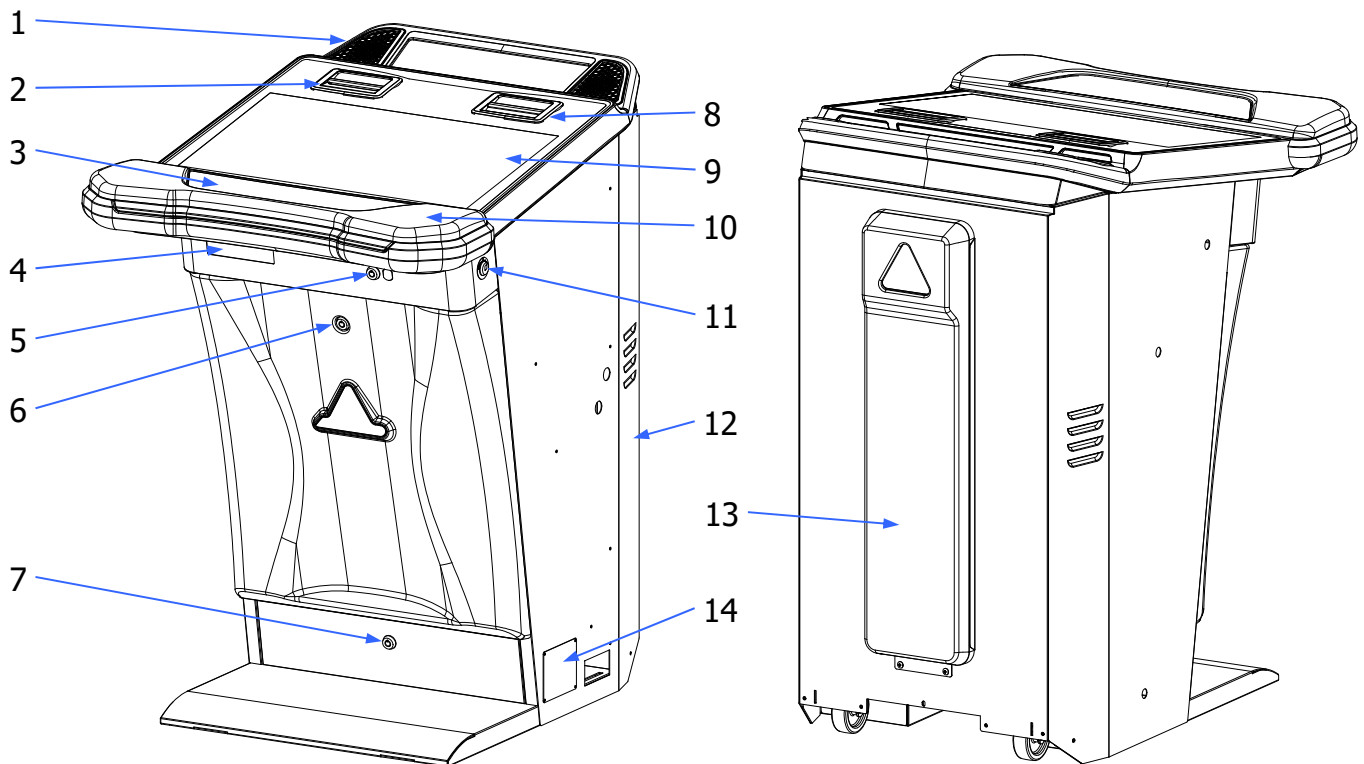

- |   |  |
|---|--|
| <ol style="list-style-type: none"> <li>1. Speakers</li> <li>2. Printer Chute</li> <li>3. Control Panel</li> <li>4. Mechanical Meters(Counter)<br/>:Used only in the regions that use the mechanical meters.</li> <li>5. Top Door Lock</li> <li>6. Front Door Lock</li> <li>7. Bottom Door Lock</li> </ol> | <ol style="list-style-type: none"> <li>8. BILL Chute</li> <li>9. Top Door</li> <li>10. Arm Rest(Pad)</li> <li>11. RESET/AUDIT Key Switch</li> <li>12. Cabinet</li> <li>13. Back LED(Optional)</li> <li>14. Serial Plate</li> </ol> |
|---|--|

## 1. 5: Inside View of Station

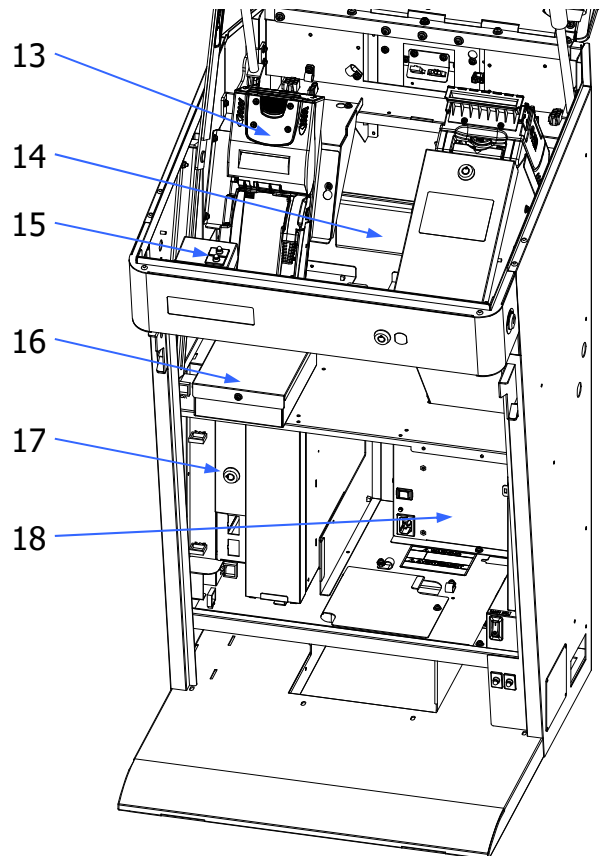
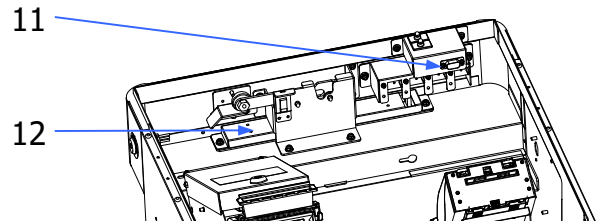
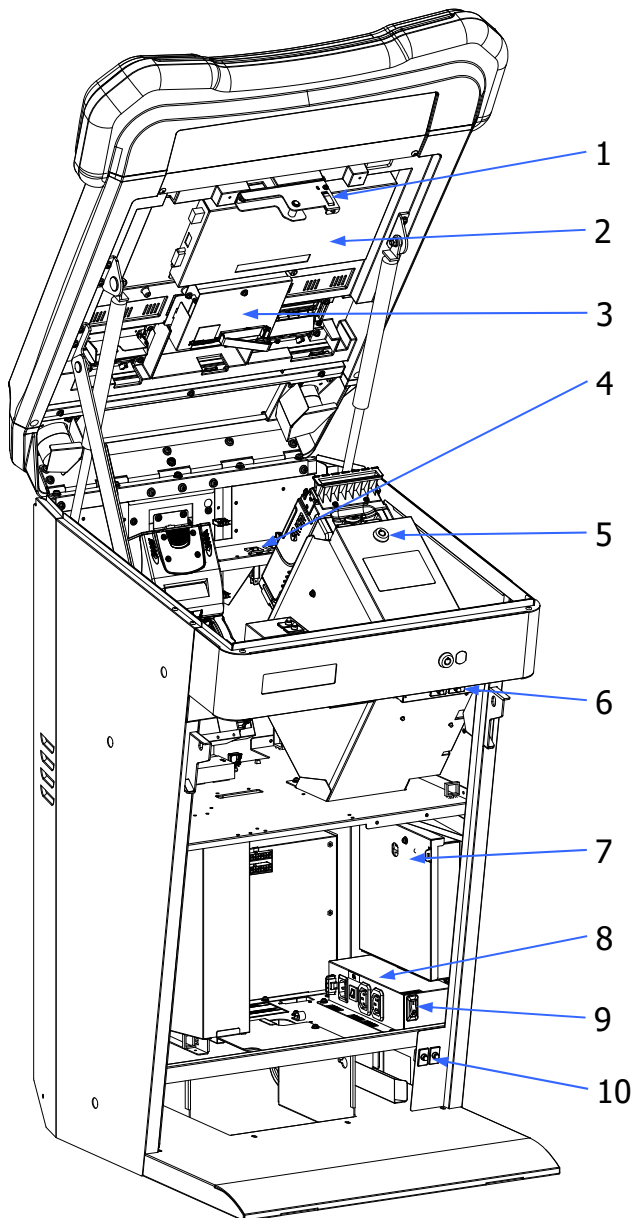

1. Top Door Sensor
2. LCD Monitor
3. Touch Screen PCB
4. Breakers
5. BILL Case(BV CASE) Door Lock
6. Front Door Switch and Sensor
7. IO Case
8. Plug-in Unit(AC Base)
9. Power Switch
10. Bottom Door Switch

11. GAT3(D SUB) Connector(Optional)
12. Front LED
13. Ticket Printer
14. Audio Module PCB
15. Top Door Switch
16. SUB IO Case(Optional)
17. Security Cage Front Cover Lock
18. Power Supply

## Chapter 2

### Unpacking and Inspection

#### 2. 1: Unpacking and Inspection

Unpack the machine, and check for shipping damage. If anything is missing or damaged, contact immediately your local office or nearest distributor.





Supplied Part	QTY
Key (B2155)	1
Reset Key	1
Tower Light (Option)	(1)

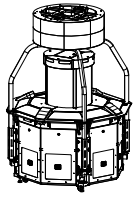
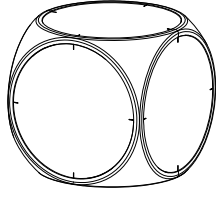
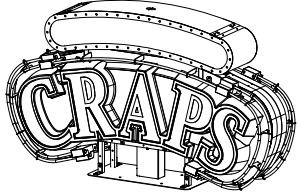
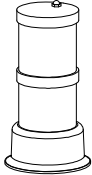
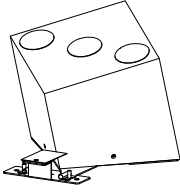
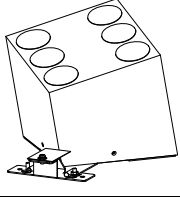
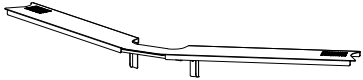
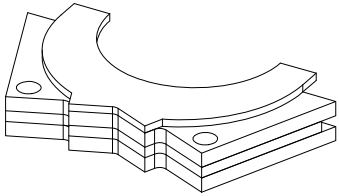

**i NOTE:**

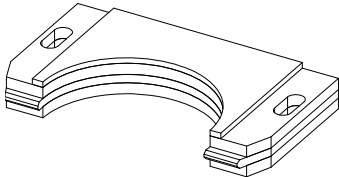
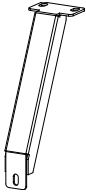
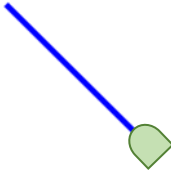
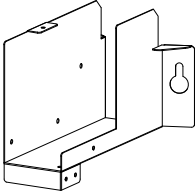
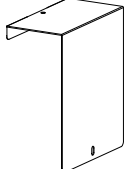
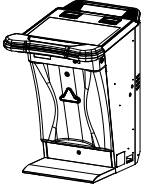
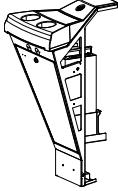
The content of the provided accessories may vary according to specifications.

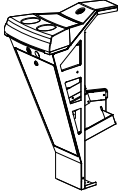

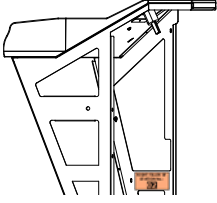
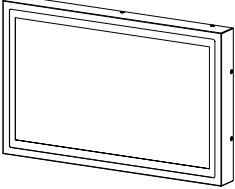

**Packing List (for Center Unit)**

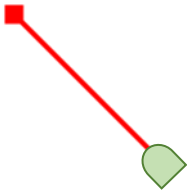
Parts Name		Qty	Appearance
1	Center Unit	1	
2	Dice	2	
3	Top Sign(CRAPS Top Box) Unit	1	
4	Tower Light	1	
5	Top Table Dice Unit [3] : [RIGHT]	2	
6	Top Table Dice Unit [6] : [LEFT]	2	
7	Joint BRKT B Unit (It can be also installed on the Center Unit)	4	
8	Joint BRKT C (for CRAPS) (It can be also installed on the Center Unit)	4	

Parts Name		Qty	Appearance
9	Joint BRKT D (for CRAPS) (It can be also installed on the Center Unit)	4	
10	Frame Joint BRKT A (It can be also installed on the Center Unit)	8	
11	AC Power Cable (3Core, 2.0Sq Cabtyre)	1	
12	Harness BRKT	2	
13	Harness Cover	2	
14	Station (STATION No.01 - 08)	8	
15	Pow Switch and HUB Spacer Unit [RIGHT FILLER OF STATION No.01] (for Power Switch and HUB)	1	 
16	Control Spacer Unit [RIGHT FILLER OF STATION No.03] (for AUDIT setting)	1	 

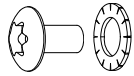
Parts Name		Qty	Appearance
17	Spacer Units (RIGHT FILLER OF STATION No.02, 04, 05, 06, 07 and 08)	6	
18	LCD Control Pad (for Control Spacer Unit)	1	
19	LAN Cable(for Station: 2.5m)	2	
19	AC Cable(for Station)	8	

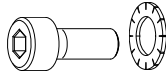
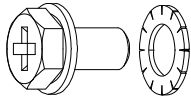
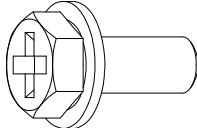
**Fastener List**

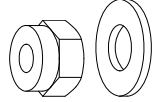
Fasteners		Appearance
A	HEXALOBULAR SOCKET BUTTON HEAD(Torx) M4x8 SERRATED LOCK WASHER 4 DIN 6798	
B	HEXAGON SOCKET BUTTON with FLANGE M4x8	
C	HEXAGON SOCKET M4x10 DIN 912 SERRATED LOCK WASHER 4 DIN 6798	
D	HEX UPSET M6x12 SERRATED LOCK WASHER 6 DIN 6798	
E	HEX UPSET M10 x 20 3P	
F	NUT M4 SPRING WASHER A4 DIN 127 WASHER A4 DIN 125	
G	NUT M3 DIN 985 WIDE WASHER 3 DIN 902	



## Chapter 3

### Installation

#### 3. 1: Whole Machine Dimension

The Whole Machine dimensions are depicted below.

Secure enough space so that the doors can be easily opened for POWER-ON/OFF, maintenance, and so on.

- **Outer Dimension - Unit: mm** (excluding all parts sticking out)

The TOWER LIGHT is optional.

Layout 8 Stations

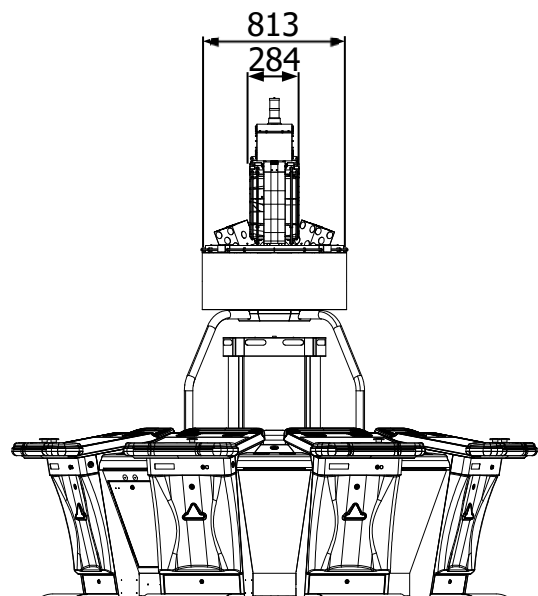
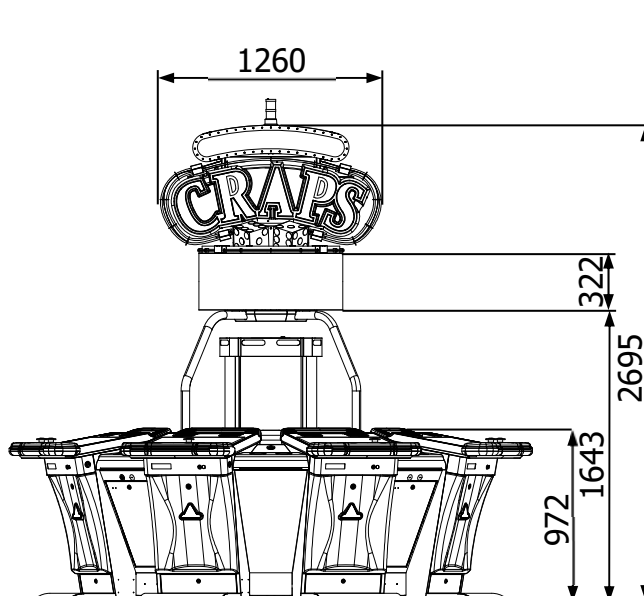
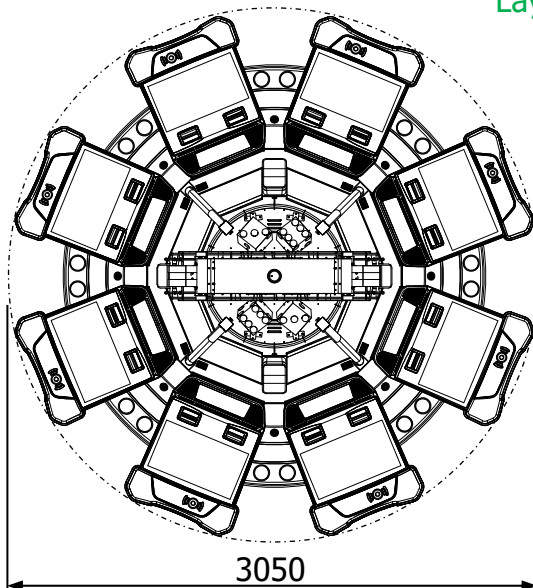

### 3. 2: Installing the Machine

#### **⚠ WARNING!**

- Installation must be performed by qualified service personnel.
- To install this machine, at least 3 people are necessary.
- Before starting installation procedures, refer to **"Safety Instructions"**.
- Interblock d.o.o. cannot be held liable for damages or injuries caused by improper installation.

#### **i NOTE:**

It is possible to install to this machine a maximum of 50 stations, including the 8 stations incorporated by the Center Unit. For more details.

**Maximum number of stations can be 50 pcs**

**Center Unit Stations 8 pcs**

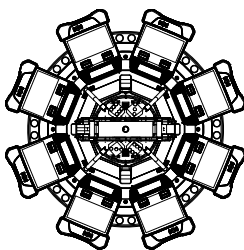

+

**Extension Stations 42 pcs**

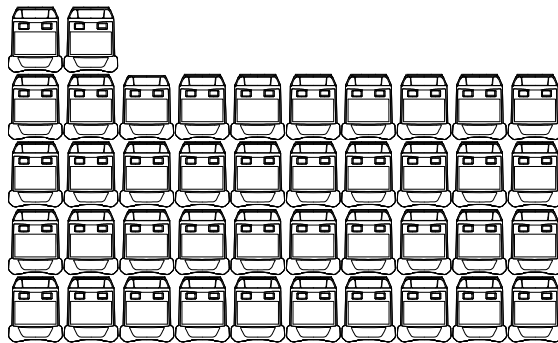

#### **[Limitation for extension]**

- Extension Stations are connected by using the LAN Cable that is included in the HUB inside the Pow Switch and HUB Spacer Unit.
- According to the number of Extension Stations and their distance, connect the Station to a 2nd HUB in relay to the HUB of the Pow Switch and HUB Spacer Unit.
- It is possible to connect up to 15 stations to each 2nd HUB.
- It is not possible to connect the 2nd HUB to a 3rd HUB. Add multiple 2nd HUBs to the HUB of the Pow Switch and HUB Spacer Unit, and diverge to each station.

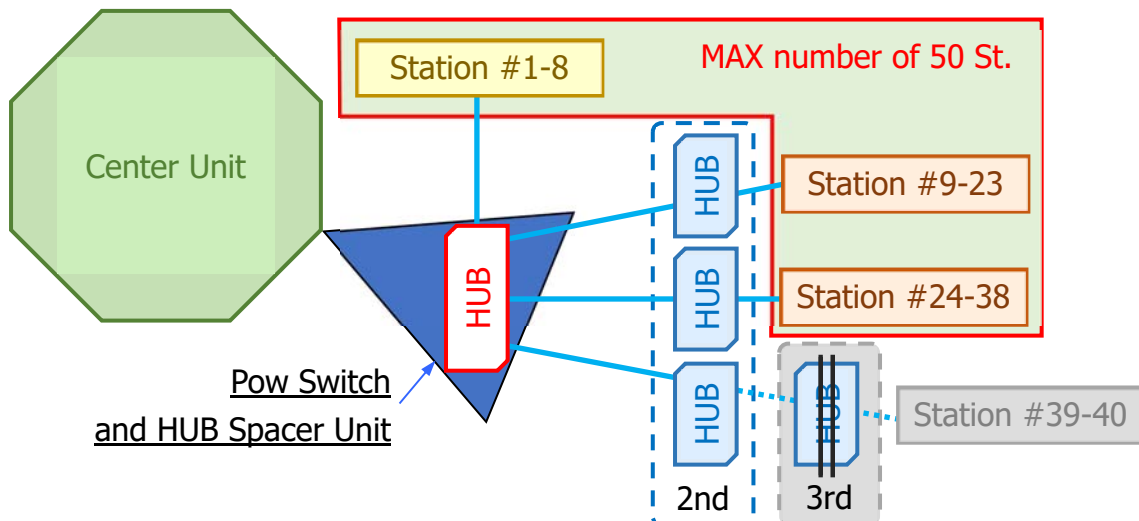

## Preparation

- To preserve the horizontal level, install the machine on a solid surface that will not suffer the influence of vibration.
- The installation requires operations on high places. Check the procedures in advance and arrange a disposition that will allow enough space for the work.
- Mount the machine in an area equipped with power and communication cables.
- This machine needs power outlets for the Center Unit and LED Panel Unit, and exclusive power plugs for each Station and the optional USB Chargers.

### **i** NOTE:

The LED Panel Unit will boot up when connected to an electrified power source. Remember that the Power Switch of the Center Unit is not connected at the same time.

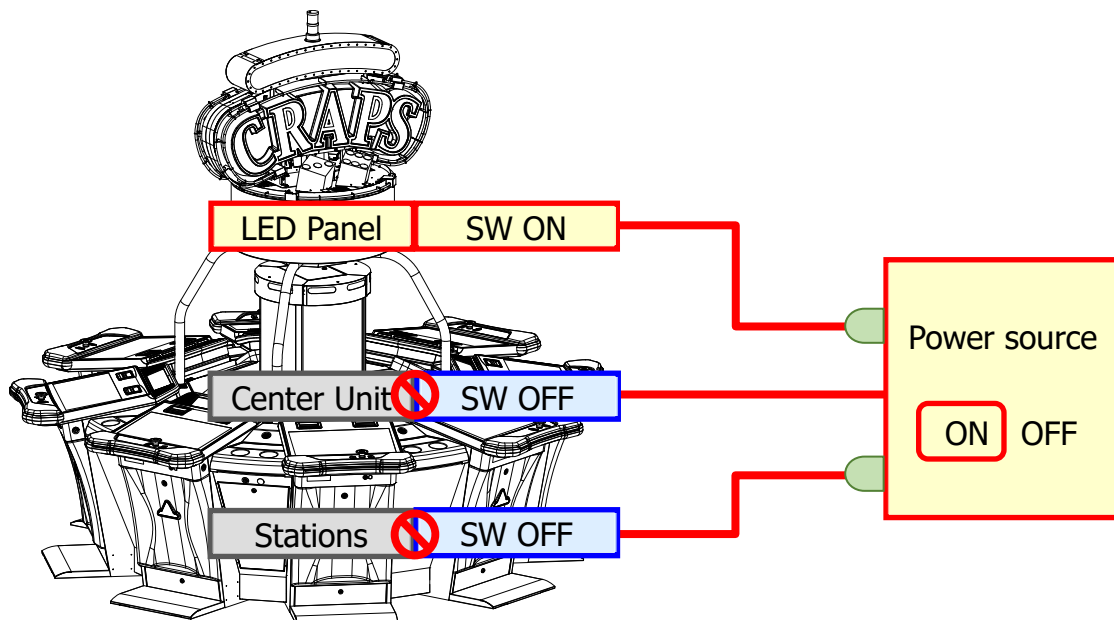

### Before installing the machine, prepare the following tools:

- Ratchet wrench with sockets of S=7, 8, 10, 12, 13, and 19mm Otherwise, open-end wrenches (+19mm) with the same sizes
- Phillips screwdriver (#2)
- HEXALOBULAR INTERNAL(Torx) screwdriver
- Hexagon wrench
- Step ladder
- Waste cloth

### 3. 2. 1: Center Unit

#### 3. 2. 1. 1: Installing the Center Unit

1. Prepare the following Parts.

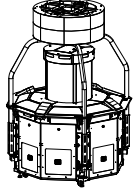
Parts Name	Qty	Appearance
Center Unit	1	

2. Remove all the shipping materials from the Center Unit. Check the exterior to verify that there are no damages etc.
3. Locate the Head Door, then unlock and remove it.

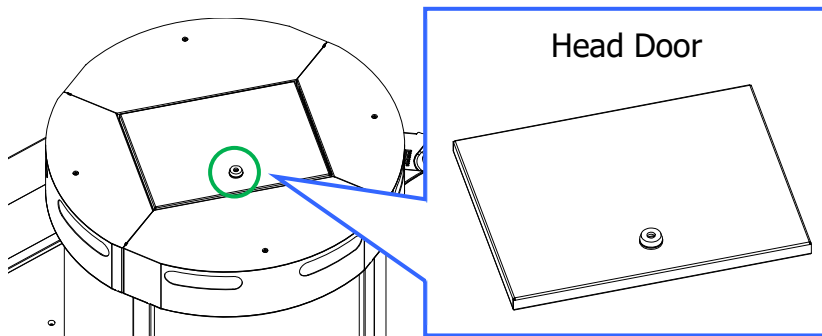

4. Remove 3 screws and detach the Head Cover A.

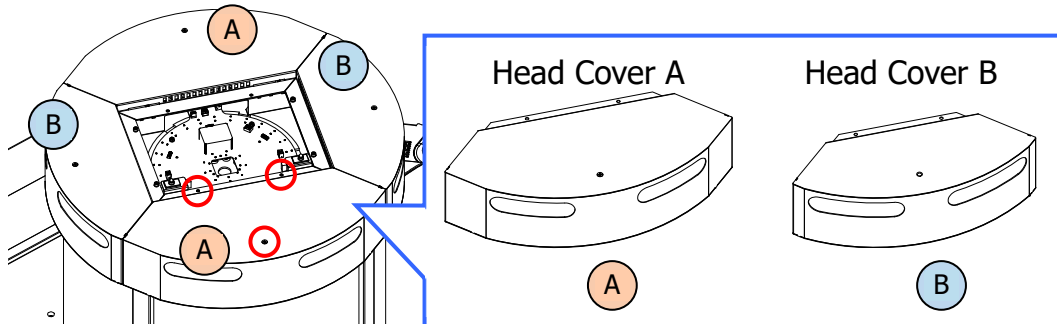

5. Remove 1 screw for each side to pull upwards and remove the 2 Glass Trims.

**! CAUTION!**

Sometimes it can be difficult to remove the Glass Trim. Please pay attention to avoid damages or injuries.

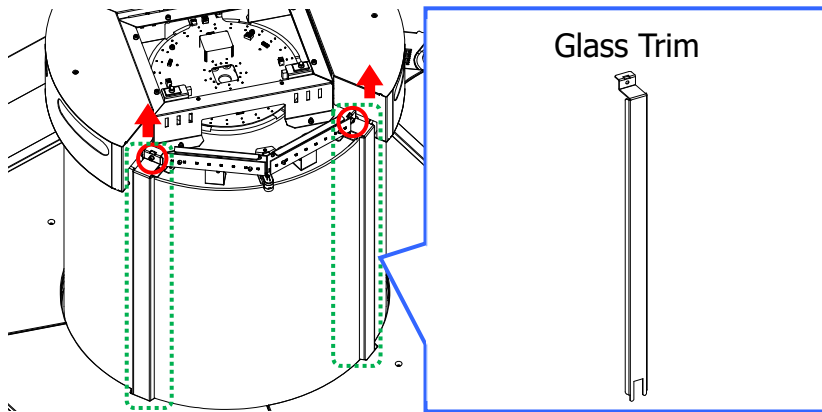

6. Paying attention not to damage the Field Glass, remove the glass by pulling forward the top of the field glass.

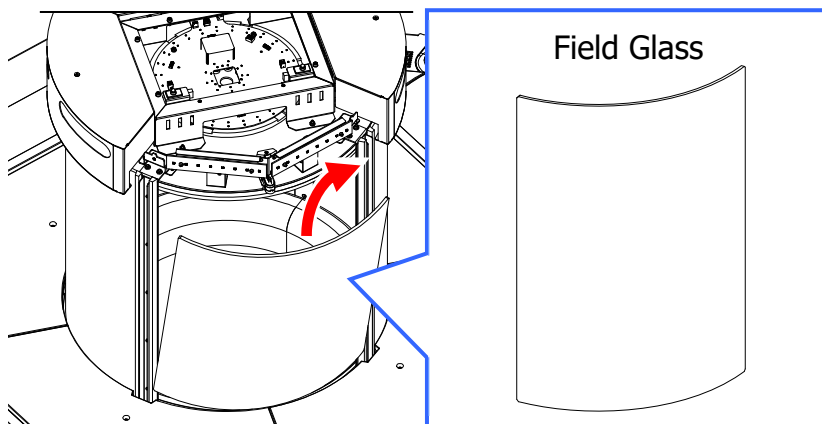

7. Prepare the following Parts.

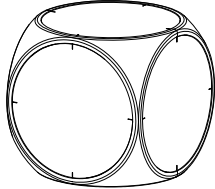
Parts Name	Qty	Appearance
Dice	2	

8. Remove the Dice from the Field area and reassembly to their original position the Field Glass, the Glass Trim, the Head Cover A and the Head Door.

9. According to the chosen layout, place the Center Unit at your desired position on a flat floor where cables for electricity and communication have already been installed.

**i NOTE:**

When planning the layout of the Center Unit, remember that its Power Cable is connected to the [Main Power Switch Unit] of the Pow Switch and HUB Spacer Unit.

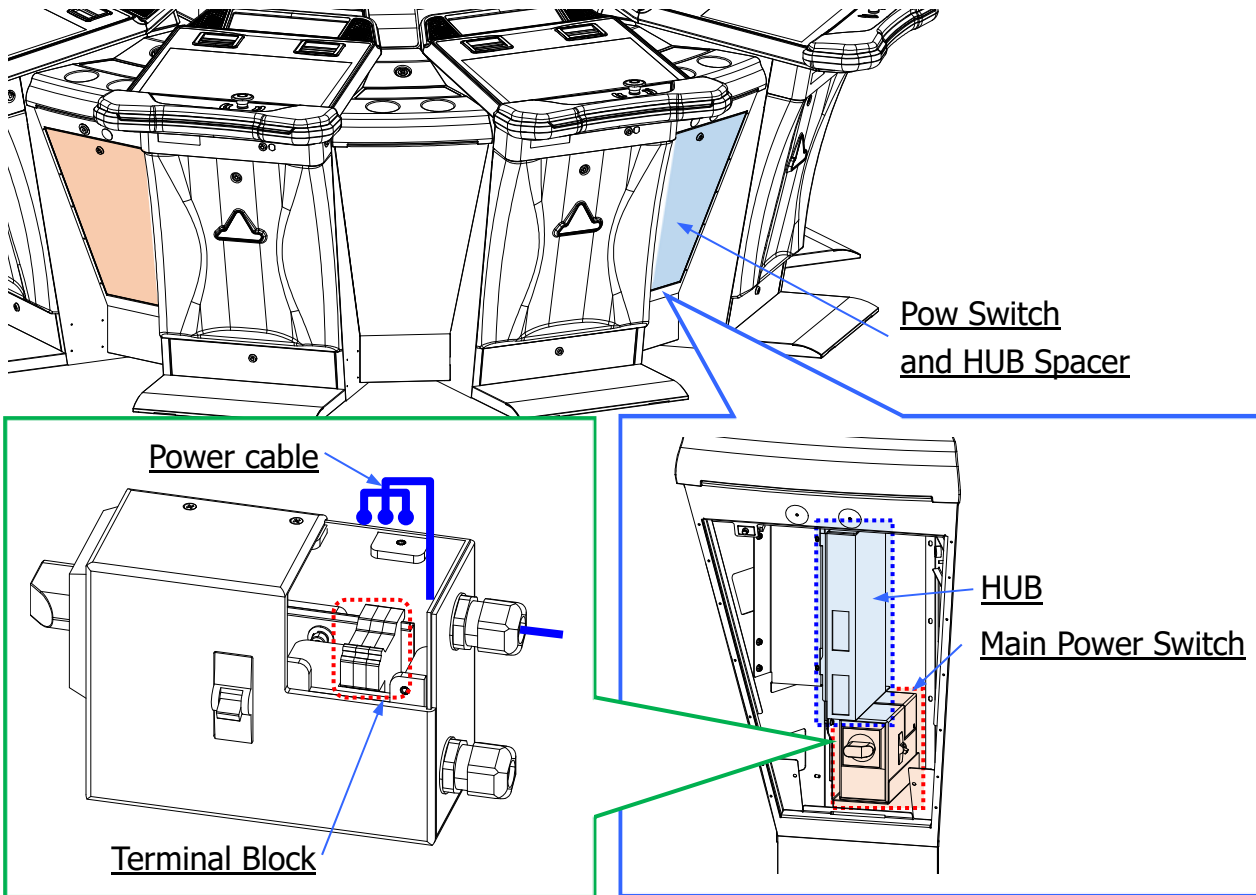

10. Secure the Center Unit to the floor by lowering the adjuster situated at the bottom of the machine.

 **WARNING!**

Secure the Center Unit so that it will not move during the installation of the LED Panel Unit.



### 3. 2. 1. 2: Preparing the Top Sign(CRAPS Top Box) Unit (Installing Tower Light)

※ The Tower Light is an optional part. Skip this paragraph if it is not necessary.

1. Prepare the following Parts.

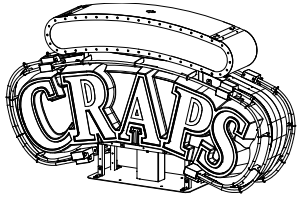
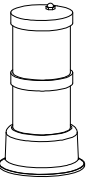
Parts Name	Qty	Appearance
Top Sign(CRAPS Top Box) Unit	1	
Tower Light	1	

2. Remove 4 screws to detach the cover of the Top Sign(CRAPS Top Box) Unit.

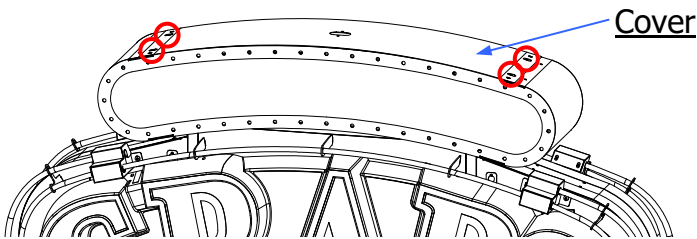

3. Thread the Tower Light Cable through the hole on the Cover, and then affix the Tower Light by using the 2 screws (UNC#8-32-X5/8) that are included with the Tower Light, together with the terminal of the Earth Cable.

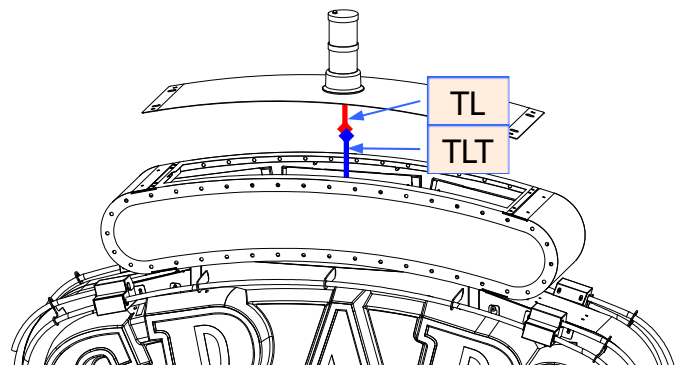
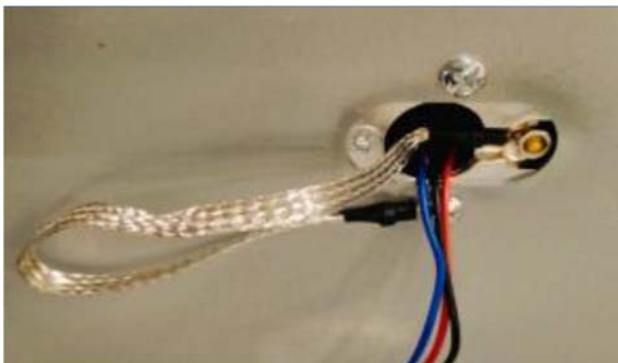

4. Connect the connector of the Tower Light to the [TLT] connector inside the Top Sign(CRAPS Top Box) Unit.
5. Return the Tower Light Plate to its original position and affix it by using screws.

### 3. 2. 1. 3: Installing the Top Sign(CRAPPS Top Box) Unit onto the Center Unit

1. First locate the Connecters on the top of the LED Panel Unit and the [PW2] and [TLS] Connecters inside the LED Panel Unit, and arrange them so that they do not interfere with the procedures.

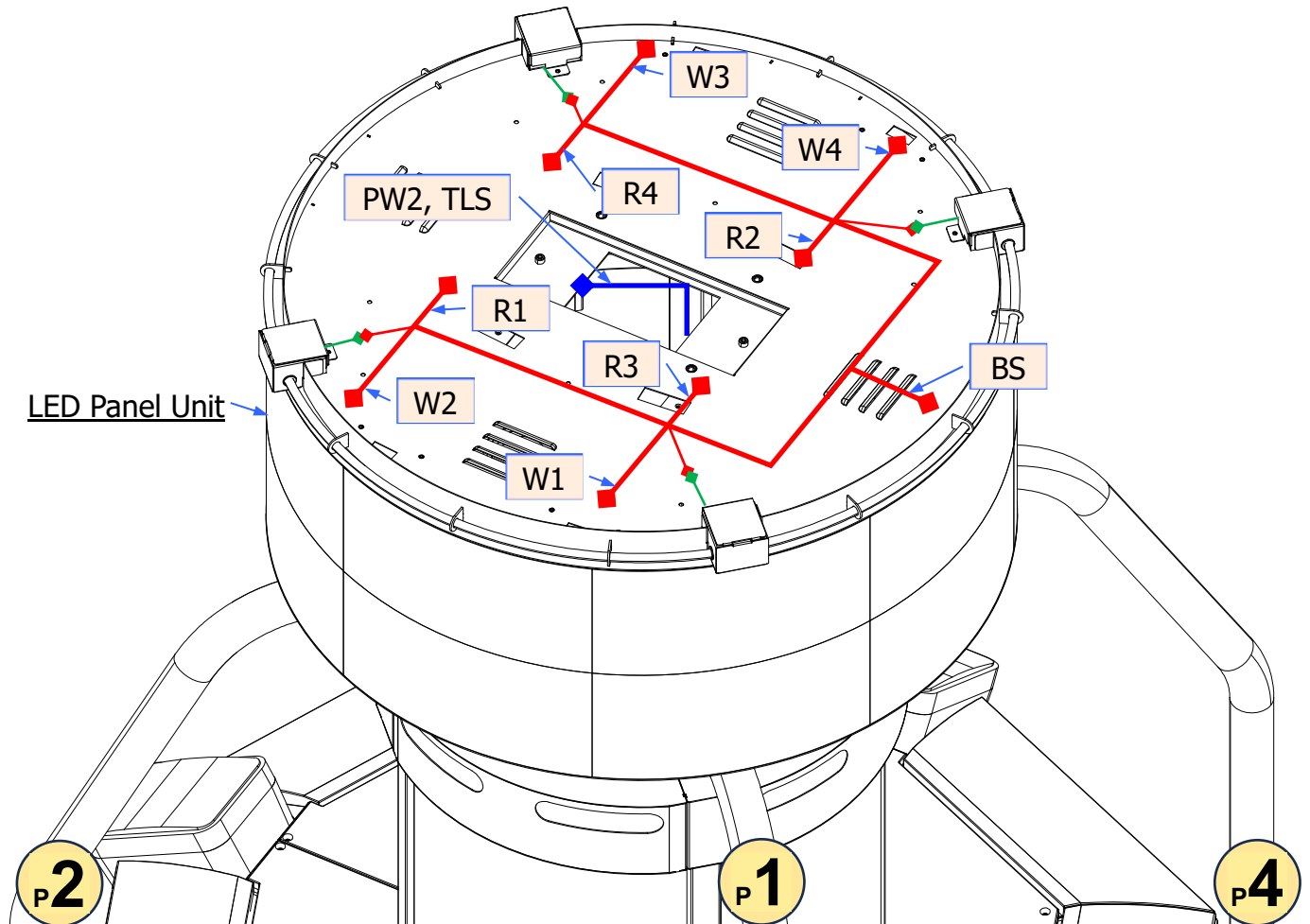

**! WARNING!**

Electrostatic discharge may damage internal components. When accessing the inside of the LED Panel Unit, take anti-static measures (as wearing antistatic wrist band, etc.) before proceeding.

**i NOTE:**

The LED Panel Unit is composed by several LED Panels. Each LED Panel is held fixed by a magnet.

**[To remove a LED Panel]**

- A. The array of the LED Panels is fixed. Refer to the LED MAP below.
- B. Insert a tool such as a spatula with no pointed tips (or a flat head screwdriver #3) between the joints, then scoop up the edge and detach the LED Panel by hand.
- C. Unplug the 2 cables that are connected to the backside, to detach the LED Panel.

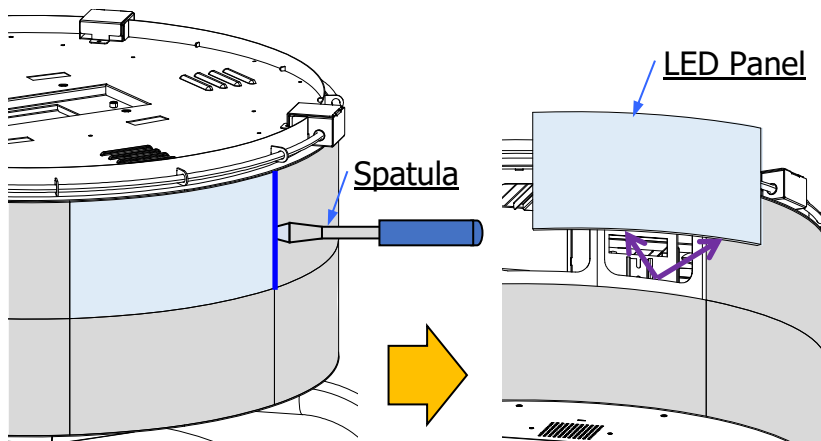
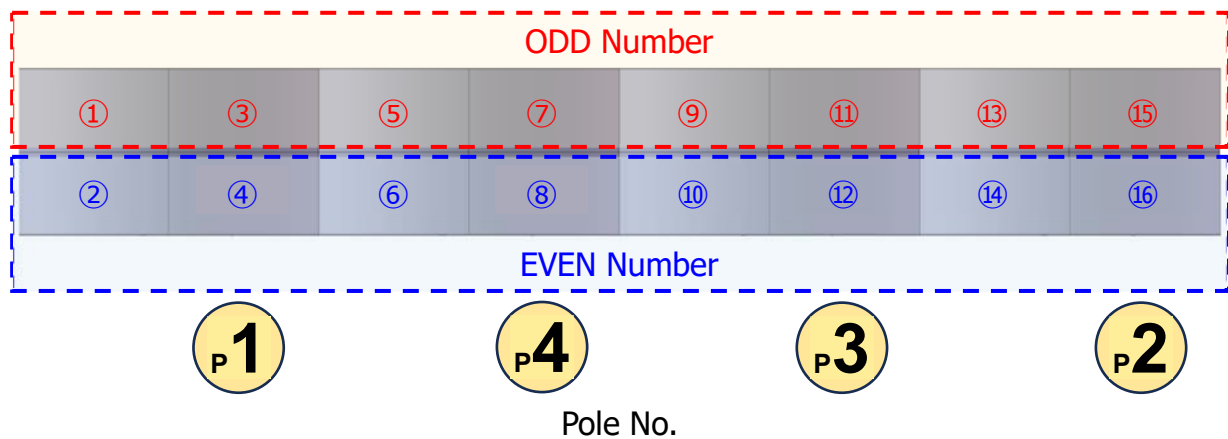

**i NOTE:**

The LED Panel Unit is composed by several LED Panels. Each LED Panel is held fixed by a magnet.

**[To install a LED Panel]**

A. The array of the cables that are connected behind the LED Panels is fixed. Refer to the LED MAP below to connect the Cables with the relative number to the JIN and POWER Connectors (in the yellow frame) of the LED Panel, then install it to the LED Panel Unit.

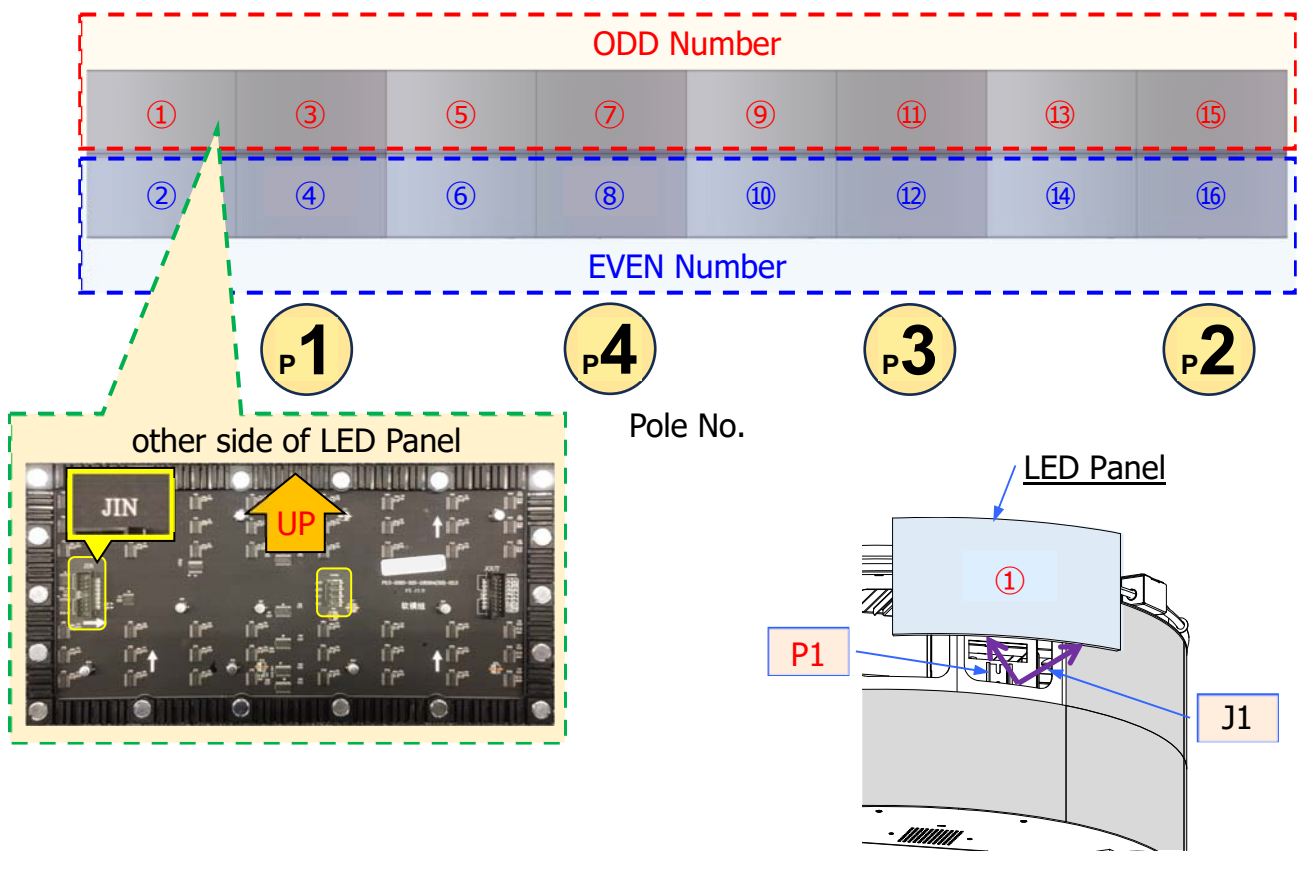

## 2. Prepare the following Parts.

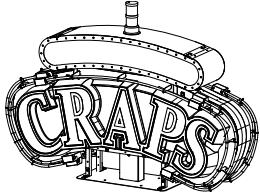
Parts Name	Qty	Appearance
Top Sign(CRAPS Top Box) Unit	1	

## 3. Remove 1 screw to detach the cover of the pillar.

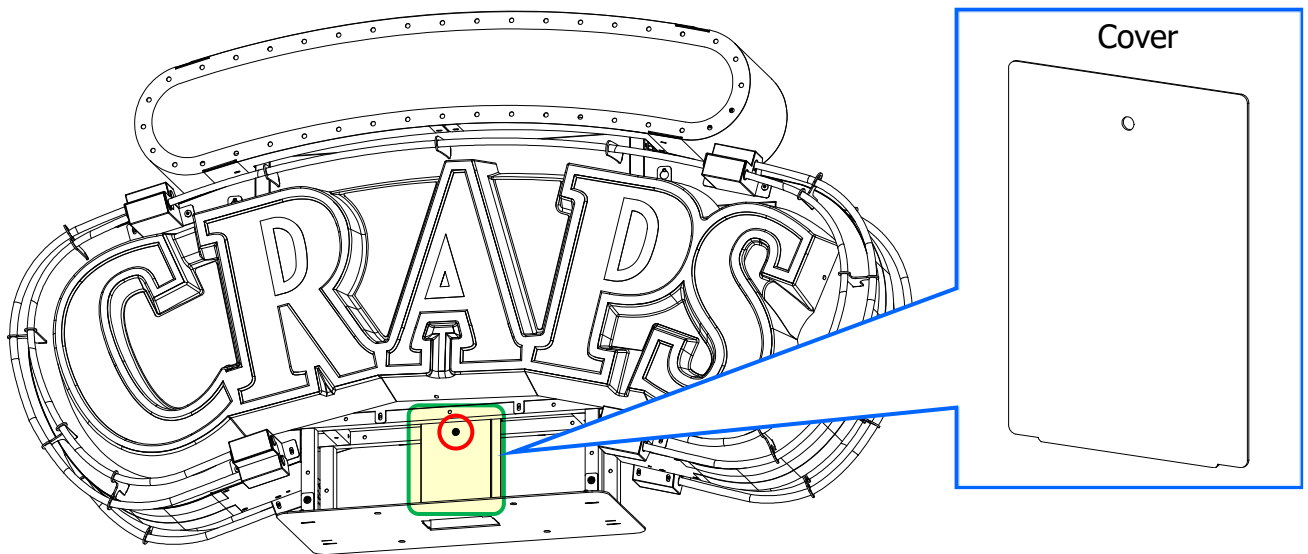

4. Install the Top Sign(CRAPS Top Box) Unit on the LED Panel Unit of the Center Unit by matching the direction of the aperture, as illustrated below. Pay attention not to pinch the cables.

**⚠ WARNING!**

- To install this machine, at least 3 people are necessary.
- Once the installing procedure is started, never let go of the Top Sign(CRAPS Top Box) Unit until it is affixed to the Center Unit.
- Since the operation will be performed in a high place, pay enough attention also to the safety of the surrounding area.

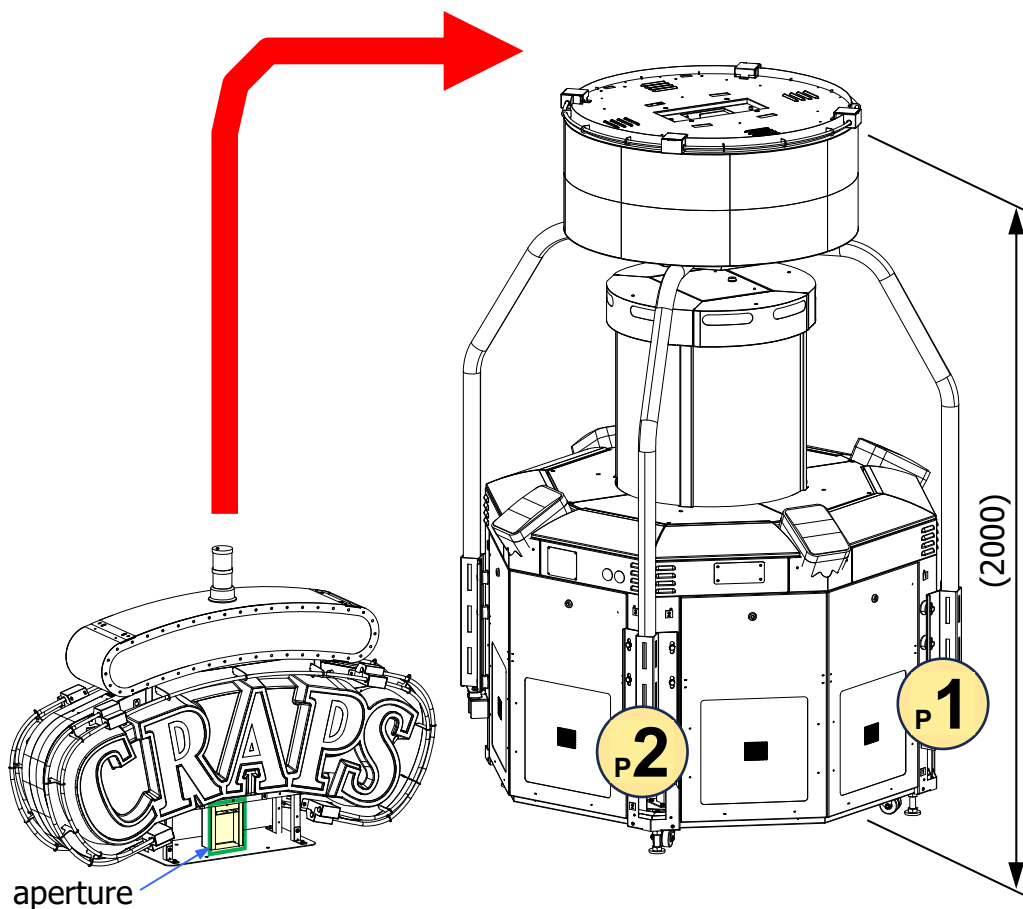

5. Refer to the illustration below to lay the Top Sign (CRAPS Top Box) Unit over the LED Panel Unit that was assembled at STEP 4, then affix it by using 4 bolts.

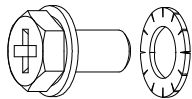
Fasteners		Qty	Appearance
D	HEX UPSET M6x12 SERRATED LOCK WASHER 6 DIN 6798	4	

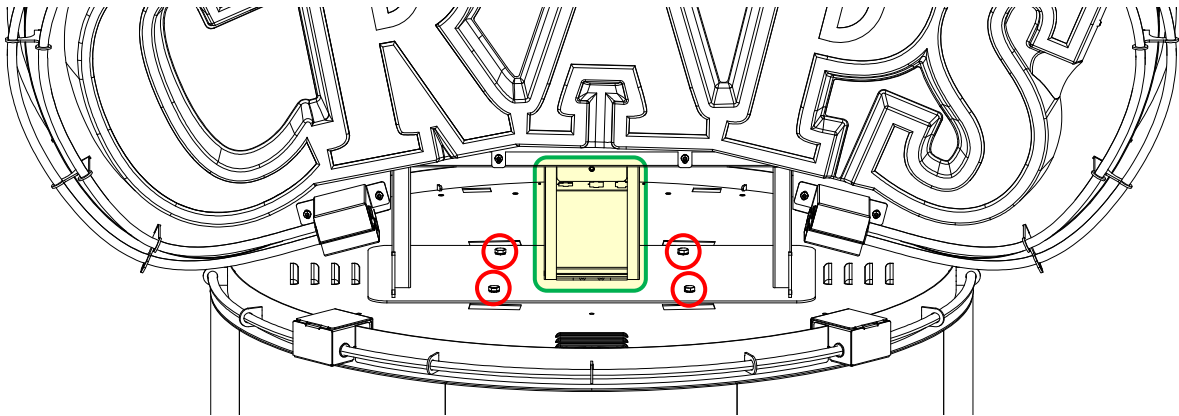

6. Connect the [PW2] and [TLS] Connectors that were checked at STEP 1, to each of the Connectors inside the pillar, then connect the [BS] Connector of the Top Sign (CRAPS Top Box) Unit to the [BS] Connector of the Top Table Unit. Re-install the cover of the pillar back to its place.

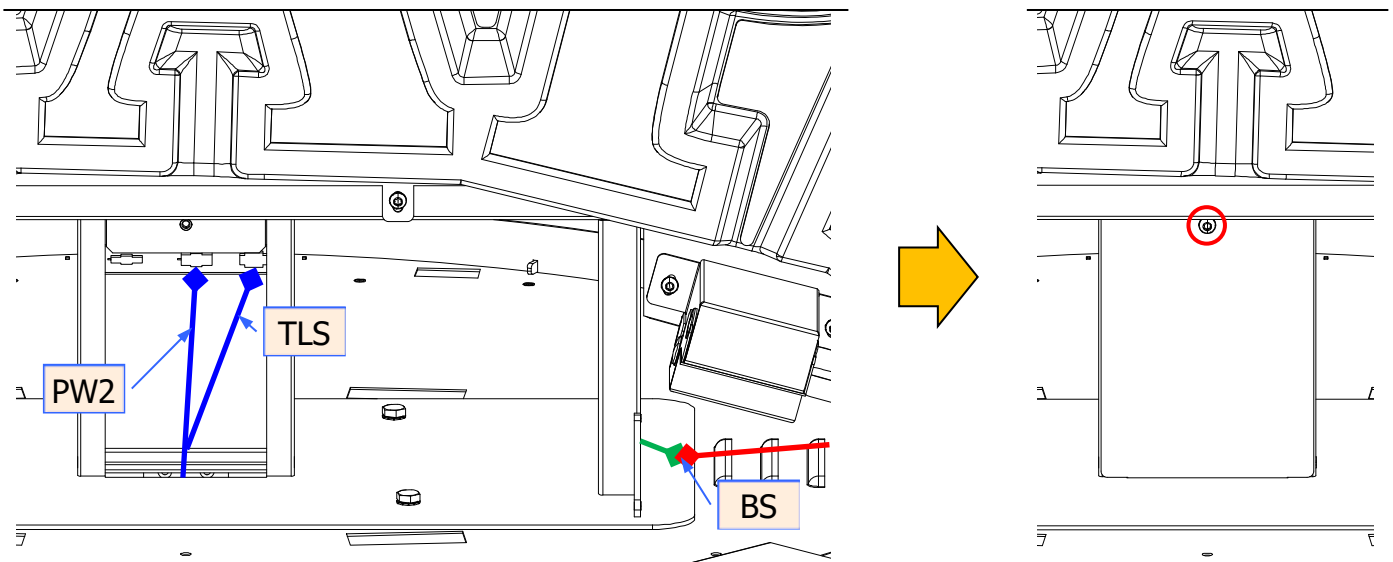

7. Prepare the following Parts.

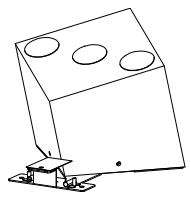
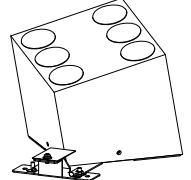
Parts Name	Qty	Appearance
Top Table Dice Unit [3] : [RIGHT]	2	
Top Table Dice Unit [6] : [LEFT]	2	

8. Secure the hook behind the Top Table Dice Unit at the top of the LED Panel Unit, the affix it by using 2 screws. Connect the [W1-W4], [R1-R4] Connectors that were checked at STEP 1, to each of the Connector of the Top Table Dice Unit.

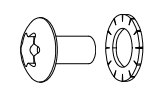
Fasteners	Qty	Appearance
A HEXALOBULAR SOCKET BUTTON HEAD(Torx) M4x8 SERRATED LOCK WASHER 4 DIN 6798	8	

**NOTE:**

The Top Table Dice unit is made by 1 SET of a left-right pair. The Unit that shows the [3] face is the right-side unit. Pay attention when installing.

[LEFT]

[RIGHT]

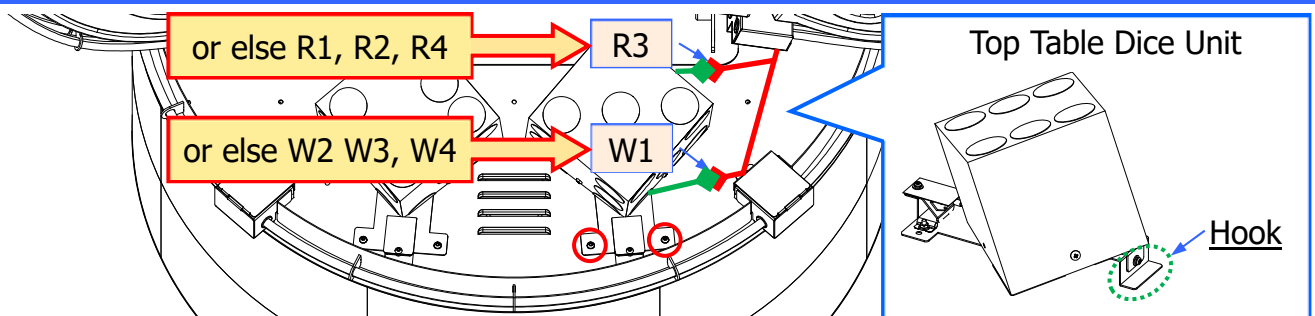
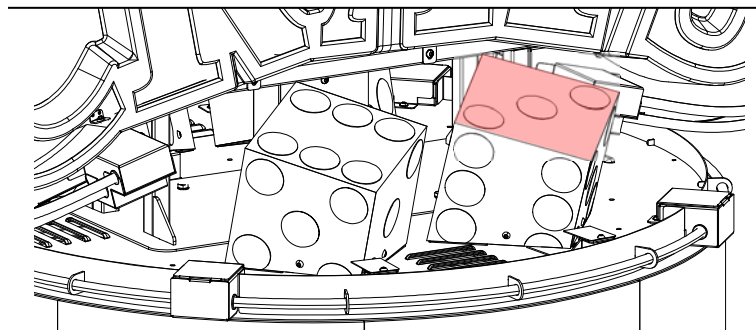
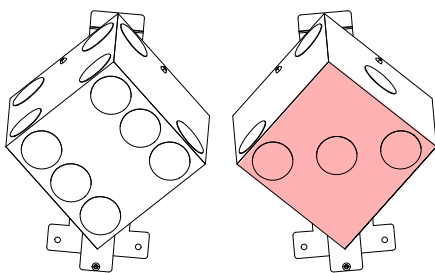

### 3. 2. 1. 4: Installing Center Unit Gap Cover

1. Prepare the following Parts.

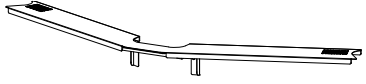
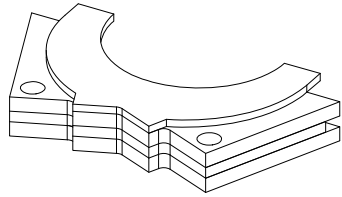
Parts Name	Qty	Appearance
Joint BRKT B Unit	2	
Joint BRKT C (for CRAPS)	4	

2. Use 1 nut on each of the Joint BRKT C (for CRAPS) to affix them to both edges of the Joint BRKT B Units.

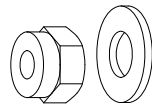
Fasteners	Qty	Appearance
G NUT M3 DIN 985 WIDE WASHER 3 DIN 902	4	

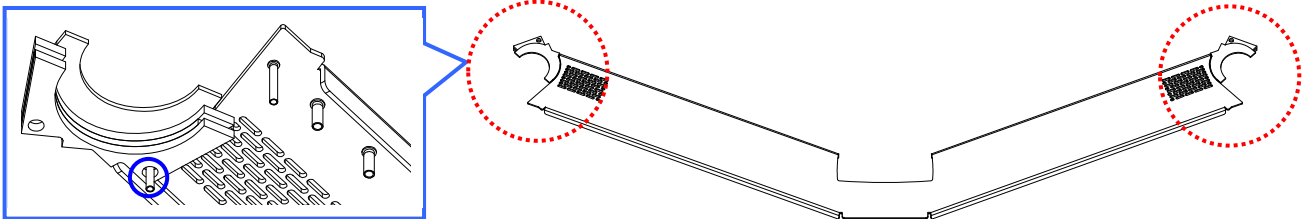

3. Affix the Joint BRKT B Units at the opposite sides of the Center Unit, by using 2 screws on each.

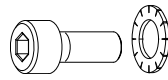
Fasteners	Qty	Appearance
C HEXAGON SOCKET M4x10 DIN 912 SERRATED LOCK WASHER 4 DIN 6798	4	

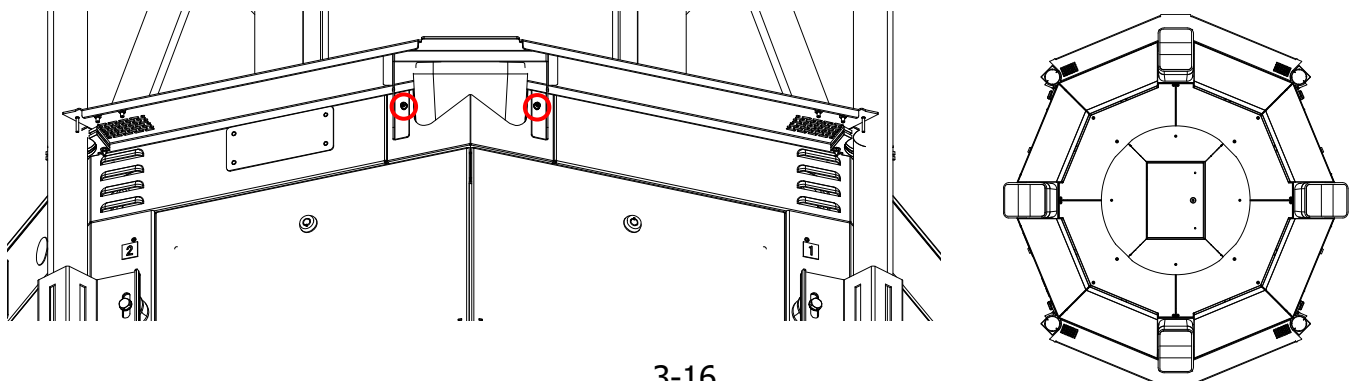

4. Prepare the following Parts.

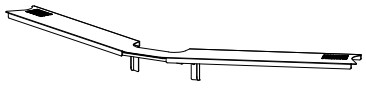
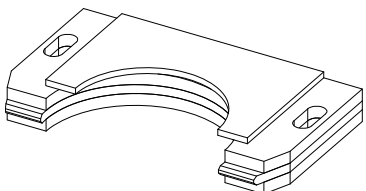
Parts Name	Qty	Appearance
Joint BRKT B Unit	2	
Joint BRKT D (for CRAPS)	4	

5. Install the remaining Joint BRKT B Units to the Center Unit, together with the Joint BRKTs D (for CRAPS), and then affix them by using 2 screws and 3 nuts on each.

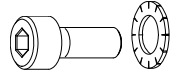
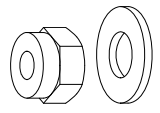

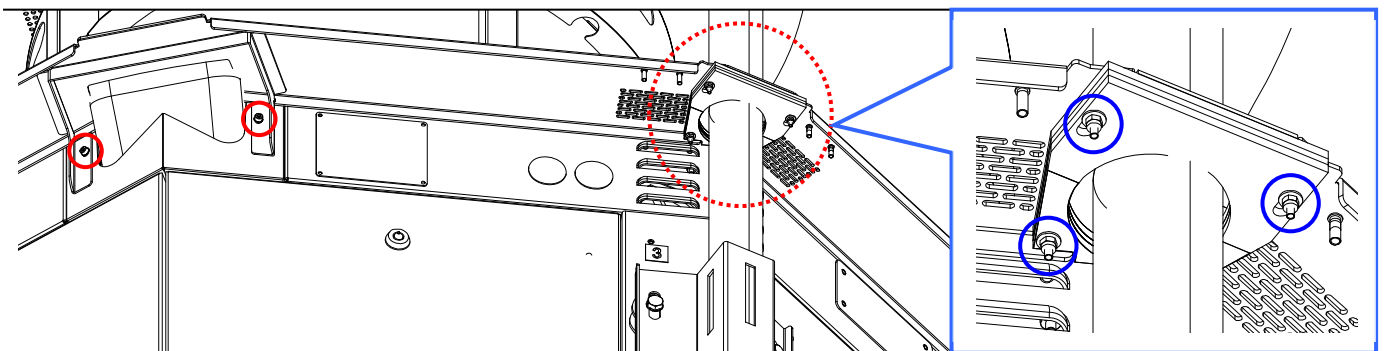
Fasteners	Qty	Appearance
C HEXAGON SOCKET M4x10 DIN 912 SERRATED LOCK WASHER 4 DIN 6798	4	
G NUT M3 DIN 985 WIDE WASHER 3 DIN 902	12	

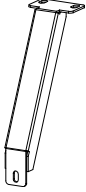

6. Prepare the following Parts.

Parts Name	Qty	Appearance
Frame Joint BRKT A	8	

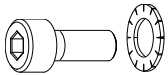
7. Affix the Frame Joint BRKT A to the Center Unit and to the Joint BRKT B Unit by using 1 screw and 2 nuts on each.

	Fasteners	Qty	Appearance
C	HEXAGON SOCKET M4x10 DIN 912 SERRATED LOCK WASHER 4 DIN 6798	8	
F	NUT M4 SPRING WASHER A4 DIN 127 WASHER A4 DIN 125	16	

At this point the machine should look like this.

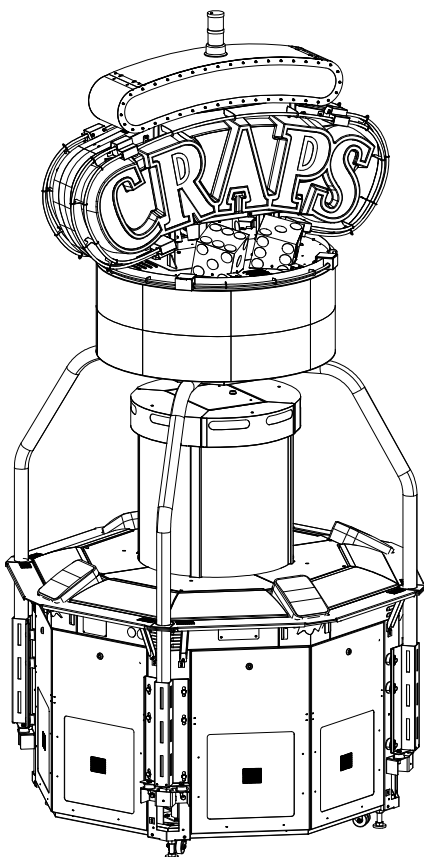
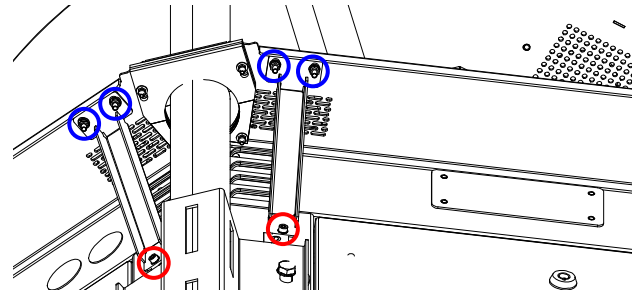

### 3. 2. 1. 5: Connecting the LED Panel Unit to the Center Unit

1. Unlock and remove the Center Unit Doors. Untie the cables tied near each Corner of the Cabinet.

**i NOTE:**

Remove first the door on the right side, and then the one on the left side.

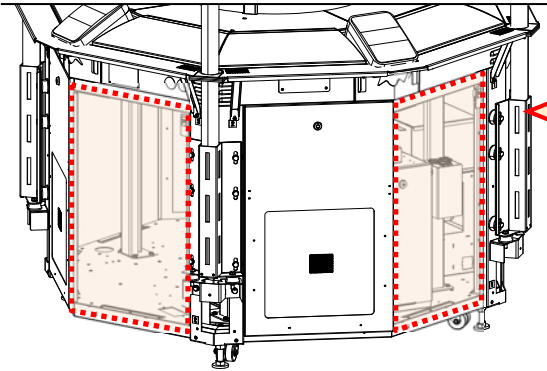

The Right Side Door is first.

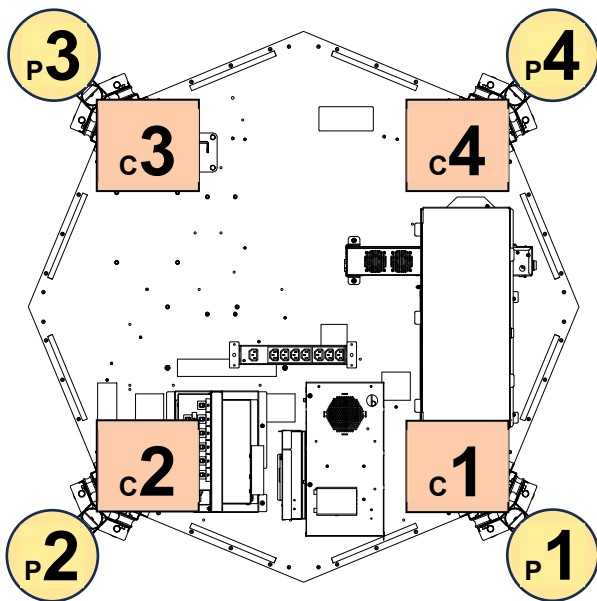
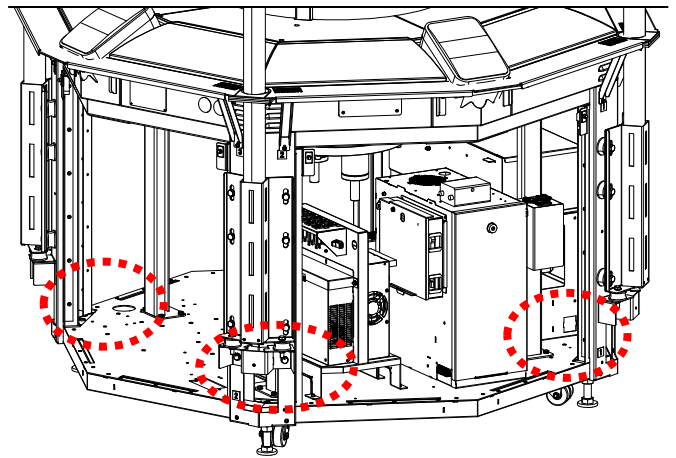

- Connect the [TLM] Connector from Pole 1, to the [TLM] Connector of the Center Unit. Connect the [DP] Connector to the [HDMI adapter] of the Center Unit. Pull the [D2] connector outside from the Center Unit, because it will be plugged later.

Corner No.	Connectors from Poles	Connectors of Center Unit
1	[TLM], [DP]	[TLM], [HDMI adapter]
2		
3		
4		

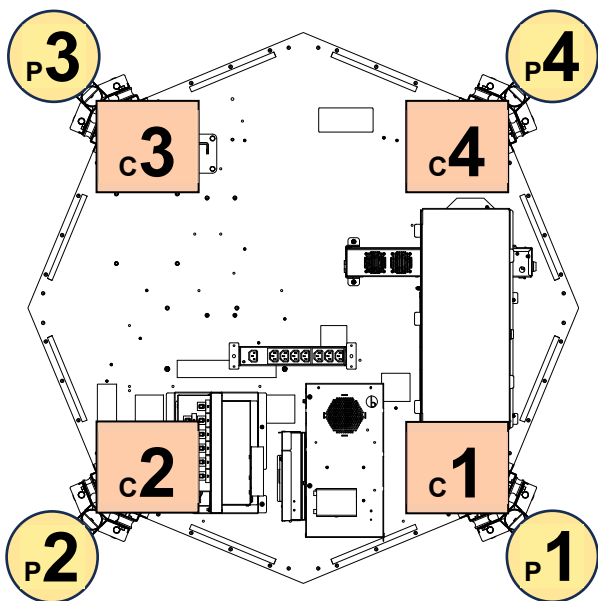
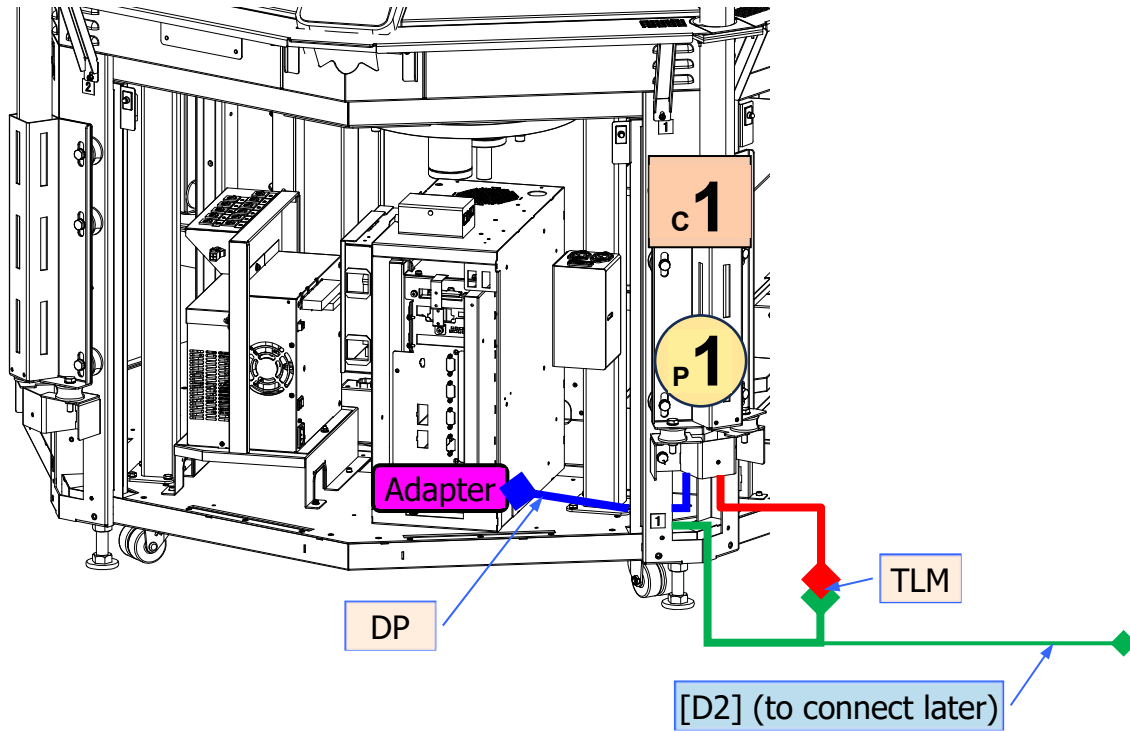

- Connect the [PZ2] Connector from Pole 2, to the [PZ2] Connector of the Center Unit. Pull all the other connectors outside from the Center Unit, because they will be plugged later.

Corner No.	Connectors from Poles	Connectors of Center Unit
1		
2	[PZ2]	[PZ2]
3		
4		

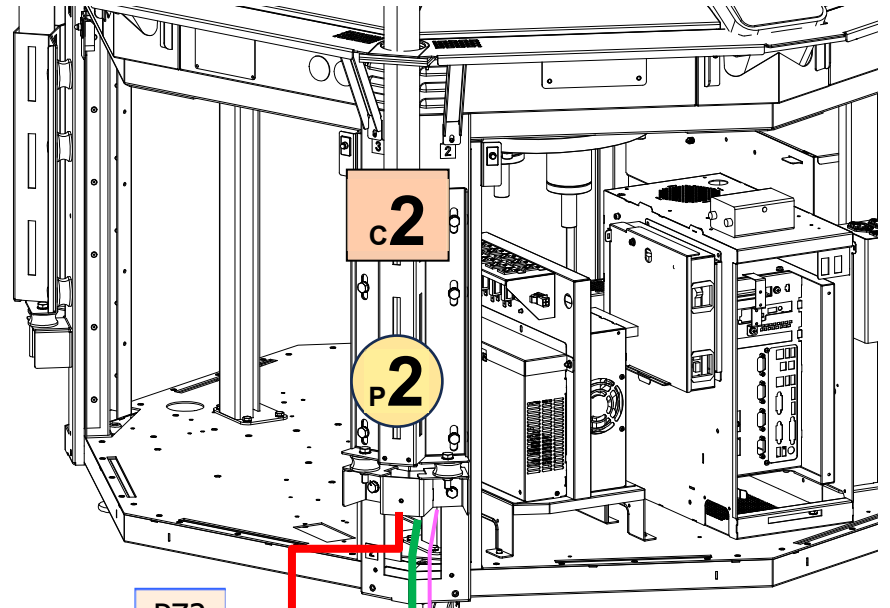

[D1], [12V] (to connect later)

[Splitter PWR], [ETD PC DP]  
[APX PCB DP2], [ETD PC USB],  
[APX PCB USB] (to connect later)

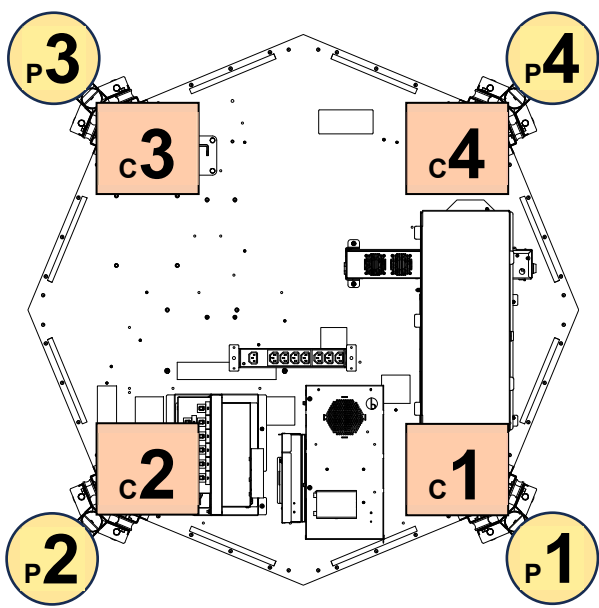

4. Connect the AC Plug from Pole 3 to the Power Relay Unit beside Corner 1.

Corner No.	Connectors from Poles	Connectors of Center Unit
1		Power Relay Unit
2		
3	AC Plug	
4		

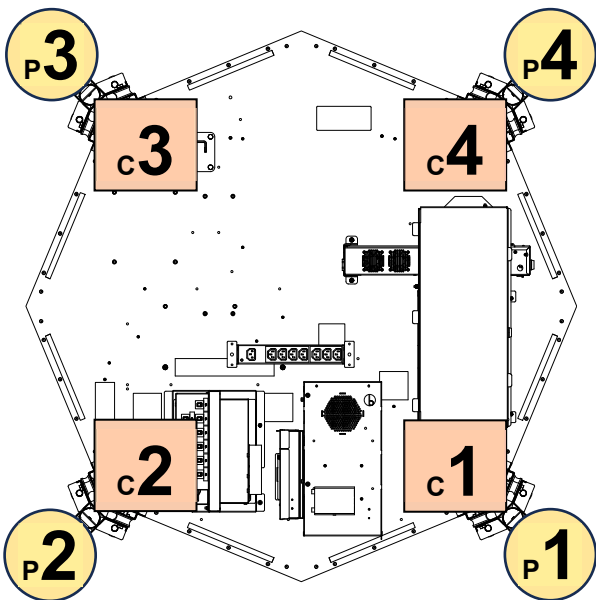
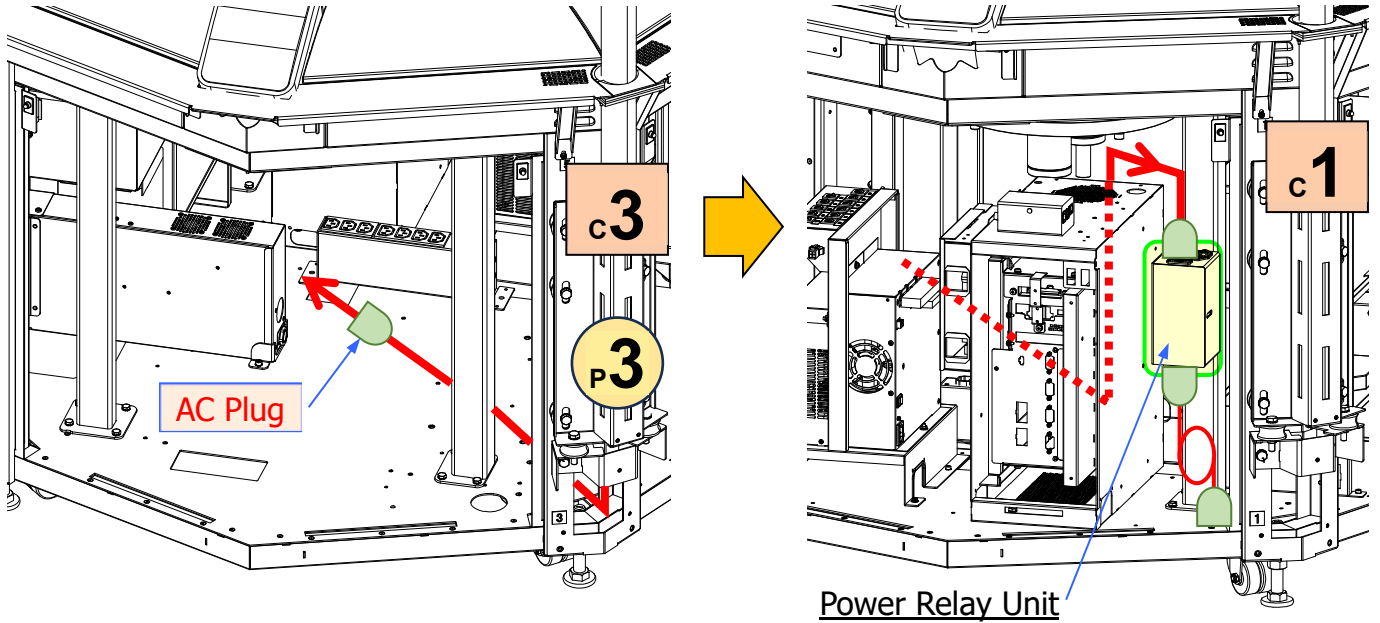

5. The connectors of the LED Panel Unit are now connected to the Center Unit. Arrange the cables installed so that they will not be an obstacle to the further procedures.

At this point the machine should look like this.

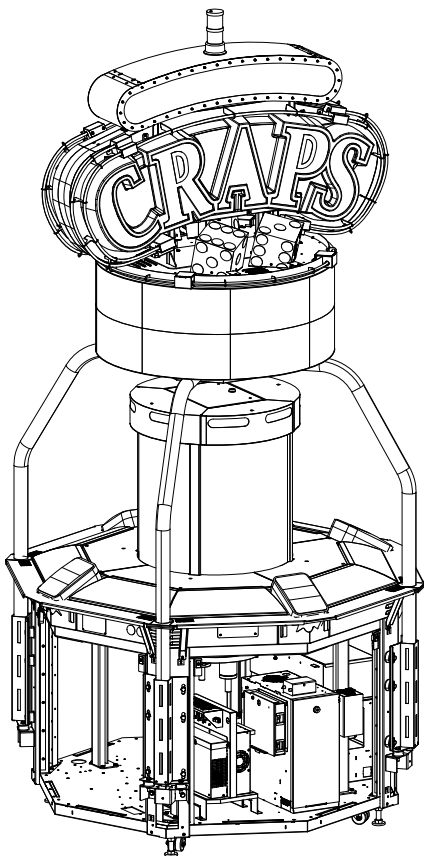

### 3. 2. 1. 6: Hardware Setting for Center Unit

Hardware Settings are necessary for factory shipped products to be operational. Before commencing with operation, make sure to do the settings explained below.



#### **WARNING!**

Electrostatic discharge may damage internal components. When accessing the inside of the Cabinet, take anti-static measures (as wearing anti-static wrist band etc.) before proceeding.



#### **CAUTION!**

Hardware Settings must be done by authorized personnel.

**- Location of PCBs -**

The PCBs that require setting are shown inside a box below.

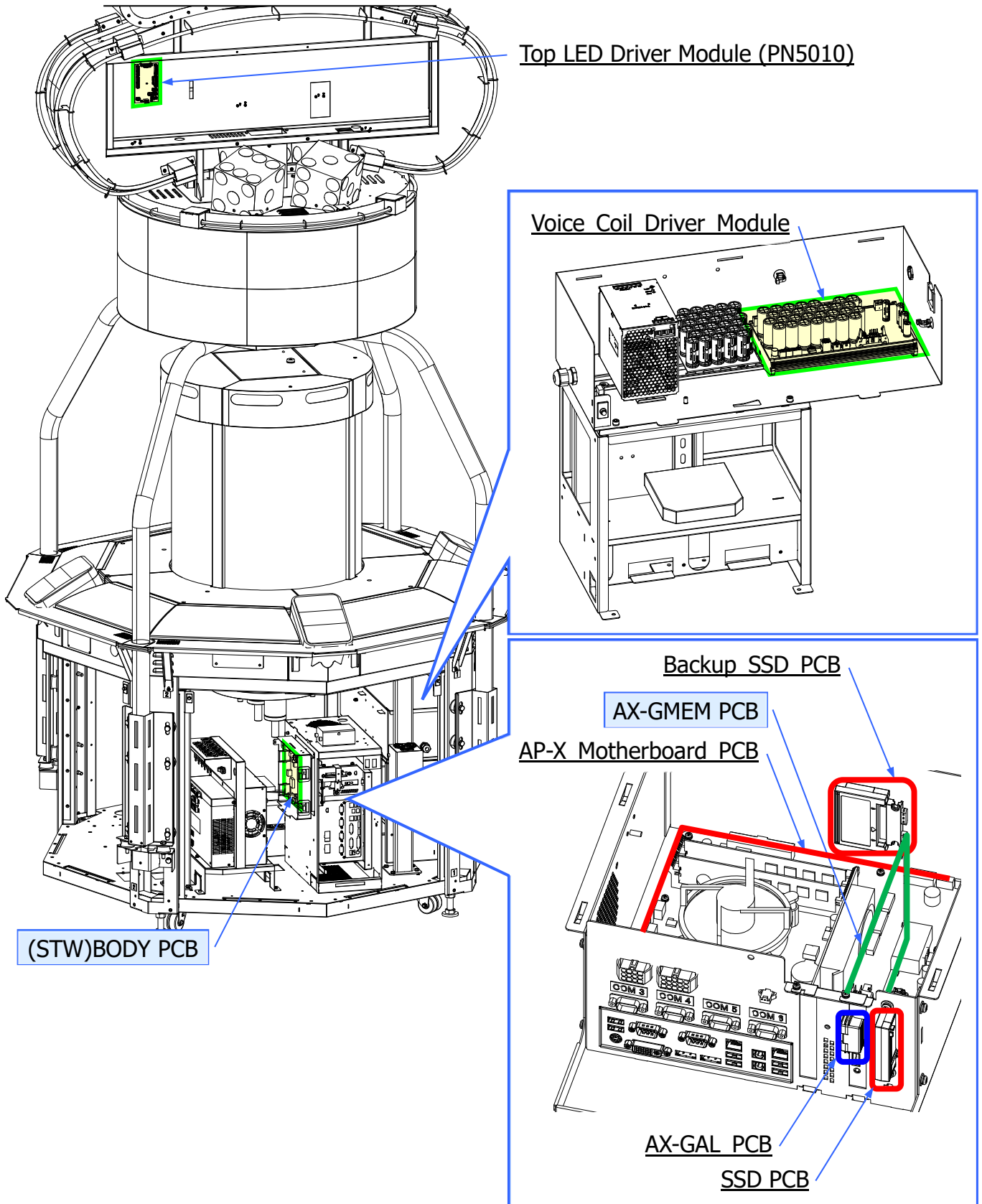

**- AX-GMEM PCB -**

PCB	Onboard Switch/Jumper	Factory Setting	Setting for Operation	Description
AX-GMEM PCB	S2 (Slide Switch)	Front (Battery OFF)	Back (Battery ON)	The switch for Backup Battery ON-OFF

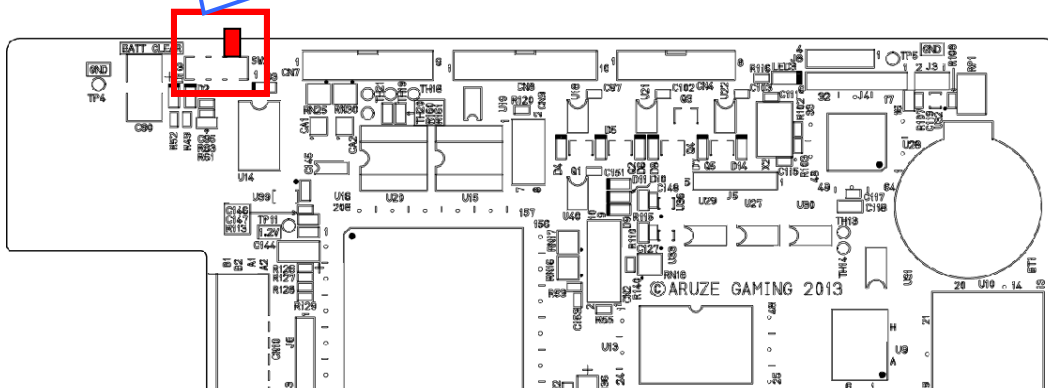
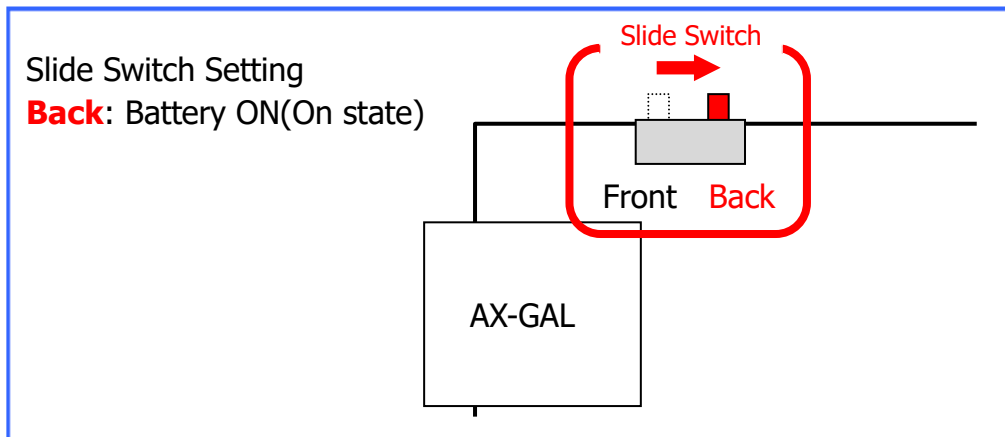
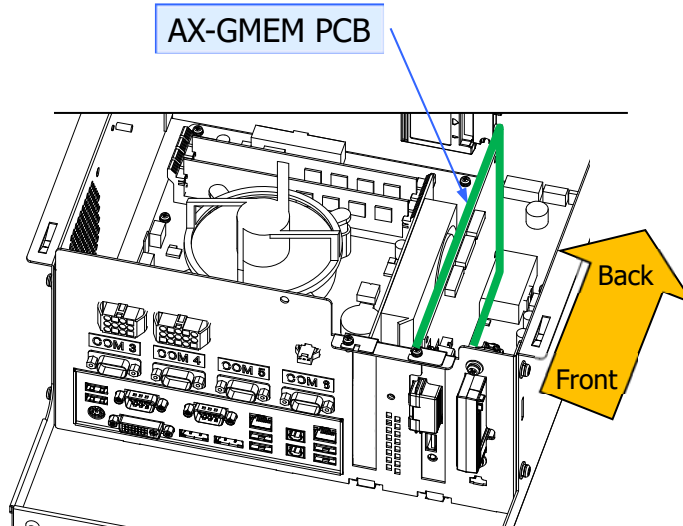

**- (STW)BODY PCB -**

PCB	Onboard Switch/Jumper	Factory Setting	Setting for Operation	Description
(STW)BODY PCB	SW2(2 Bit Dip Switch)	All OFF (Invalid)	All ON	The switch for enabling the Backup Battery

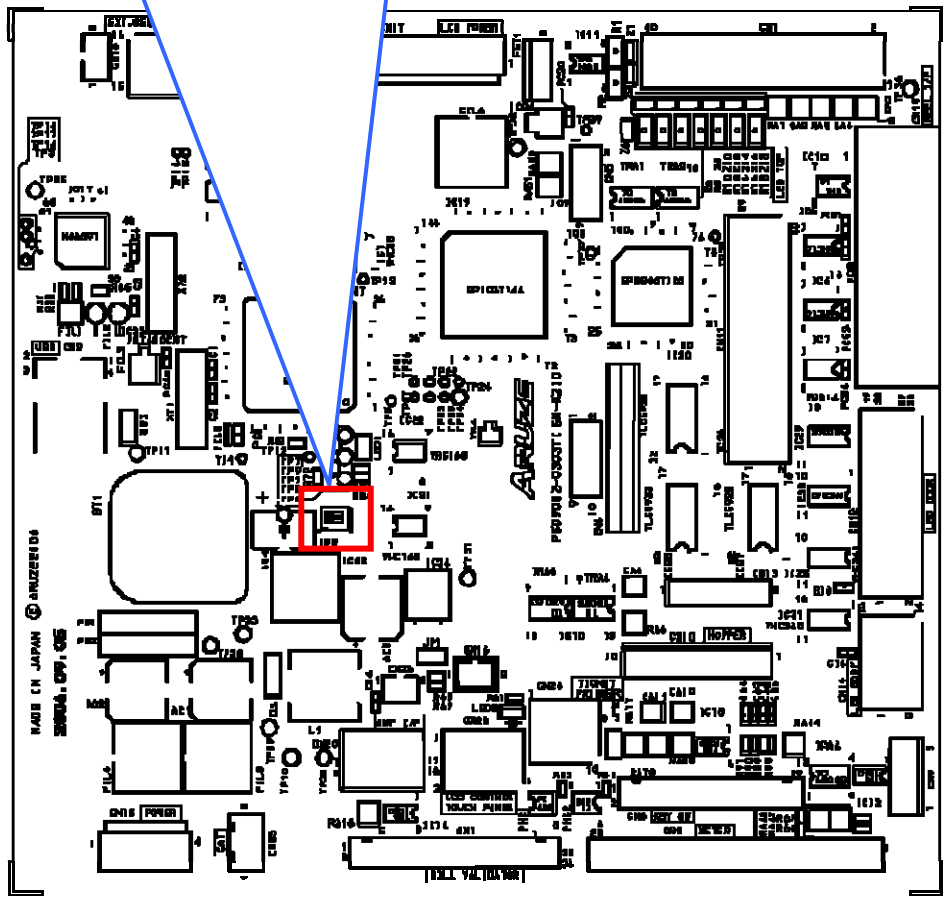
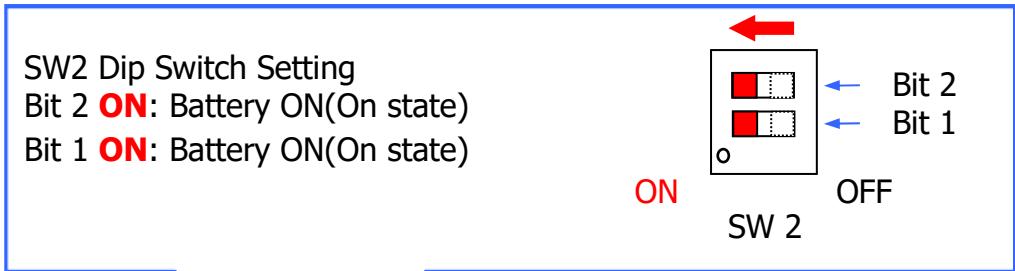
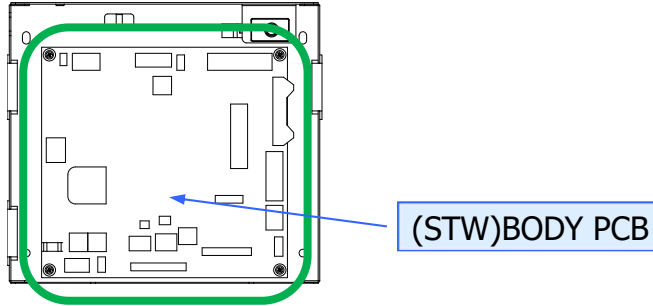

### 3. 2. 1. 7: Connecting the Center Unit to the Power Source

1. Remove 2 screws from the Main Power Switch Unit that is connected to the AC Cable from the Center Unit, to remove the Cover.

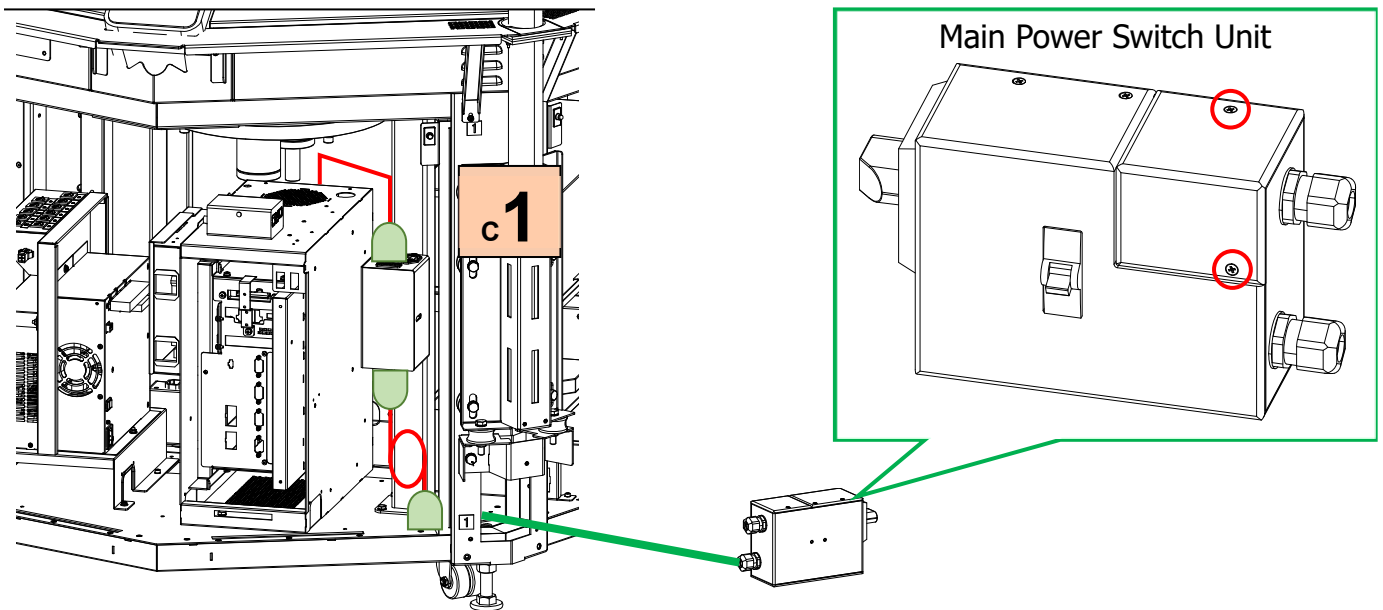

2. Prepare the following Parts.

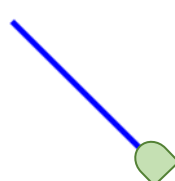
Parts Name	Qty	Appearance
AC Power Cable (3Core, 2.0Sq Cabtyre)	1	

3. Insert AC Power Cable at the back of the Main Power Switch Unit, then turn the Bush to fix the AC Power Cable.

#### **⚠ DANGER! Risk of Electric Shock.**

- The procedure for the connection to the Terminal Block can be performed only by electrical contractors or by qualified electricians.
- Before connecting power line, make sure to check that the power is OFF.

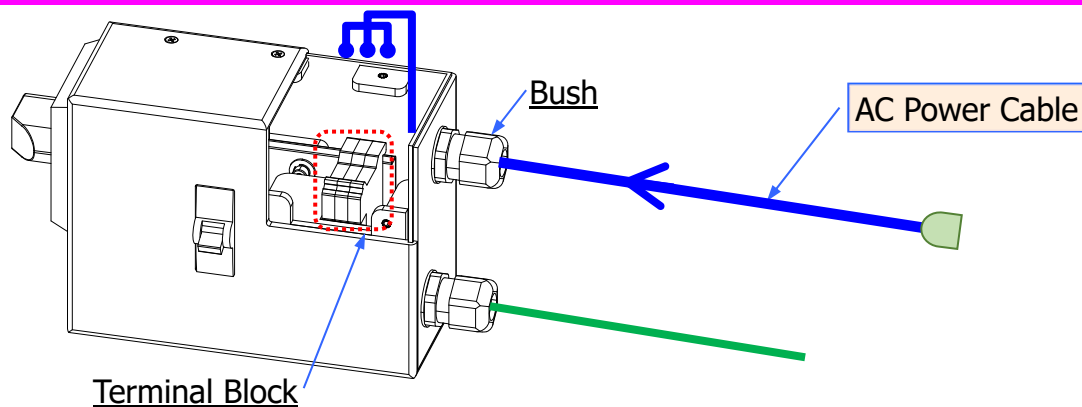

4. Connect the AC power cable to the terminal block, then return the Cover to its original position.

7Description of terminal notation
L : Live
PE : Protective Earth
N : Neutral

5. Pass the AC Plug connected to the [Power Relay Unit] outside the Center Unit through the hole of Corner 1 illustrated below, and pull it outside the Center Unit.  
Connect the AC Plug of the [Power Relay Unit] and [Main Power Switch Unit] to the Power receptacle previously prepared.



### CAUTION!

Do not electrify the Power Receptacle.

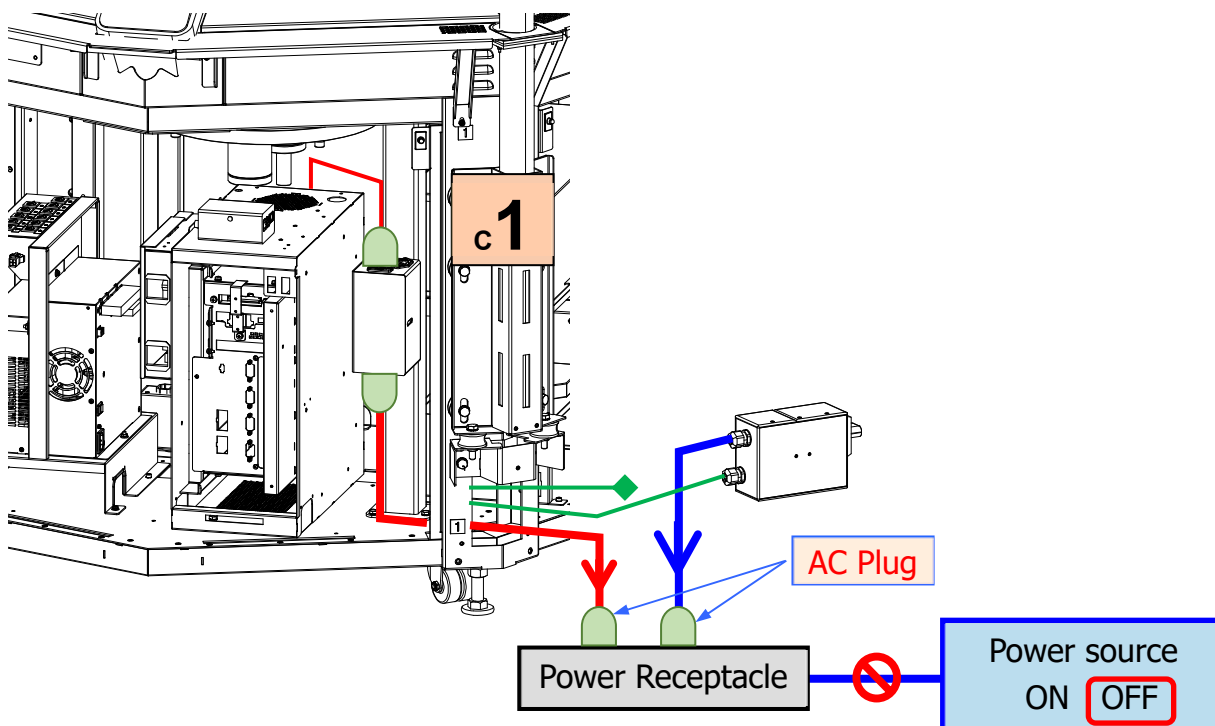

### 3. 2. 1. 8: Preparation to install the Stations

1. Pull the AC power cable (for HUB unit), that is located near the Power Distribution Unit, outside the Centre Unit through the hole at the side of Corner 1 illustrated below.

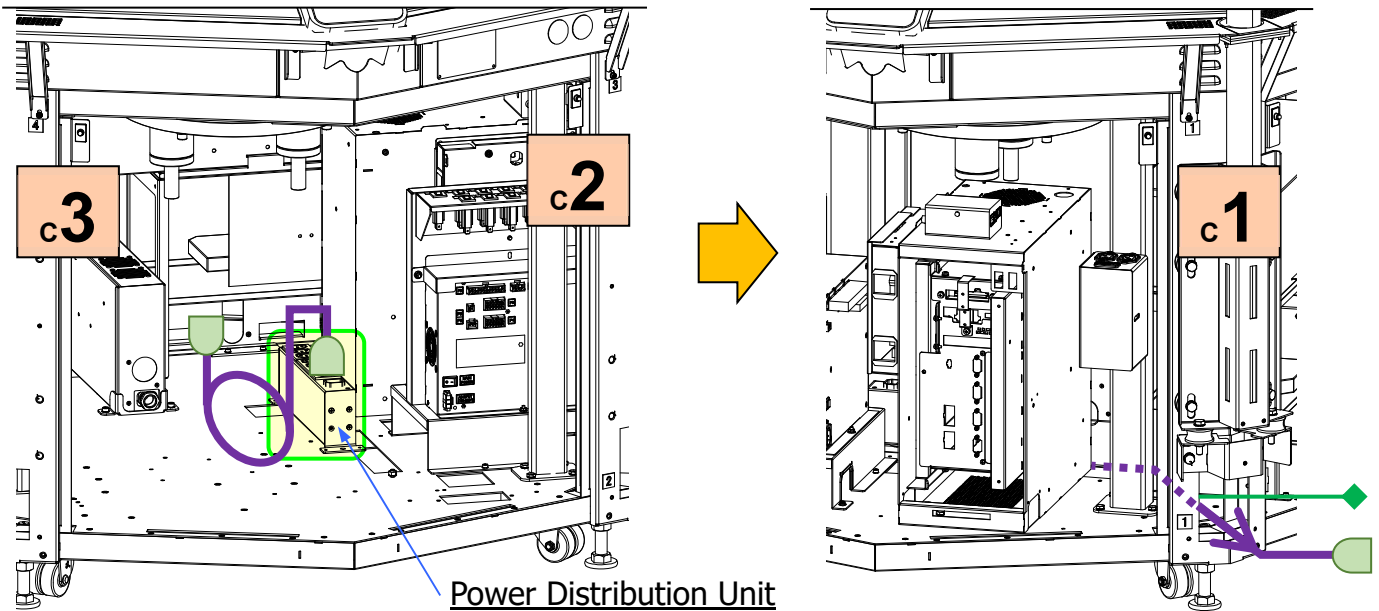

2. Pull the 9 LAN Cables located at Corner 1, outside the Centre Unit through the hole illustrated below.

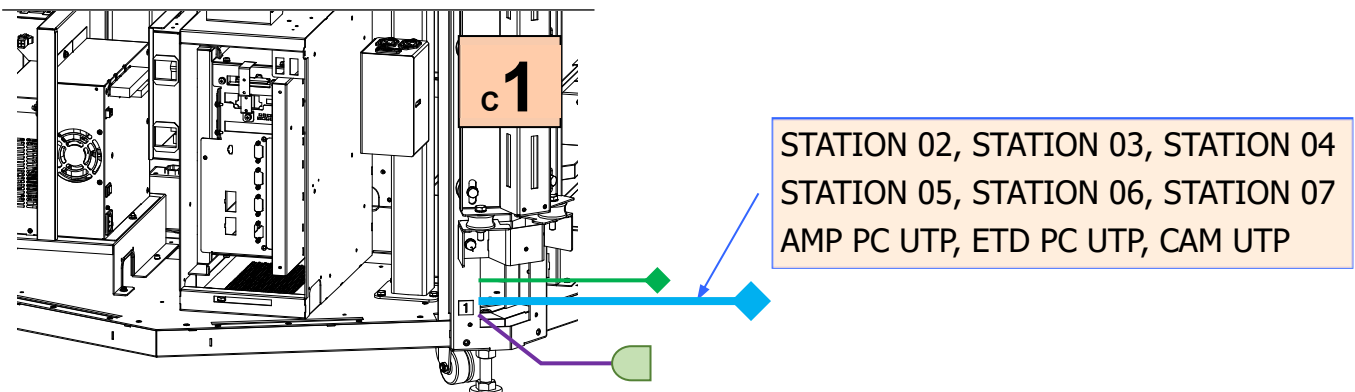

3. Pull the 2 LAN Cables located at each Corner 2, Corner 3, Corner 4, outside the Centre Unit through the holes illustrated below.

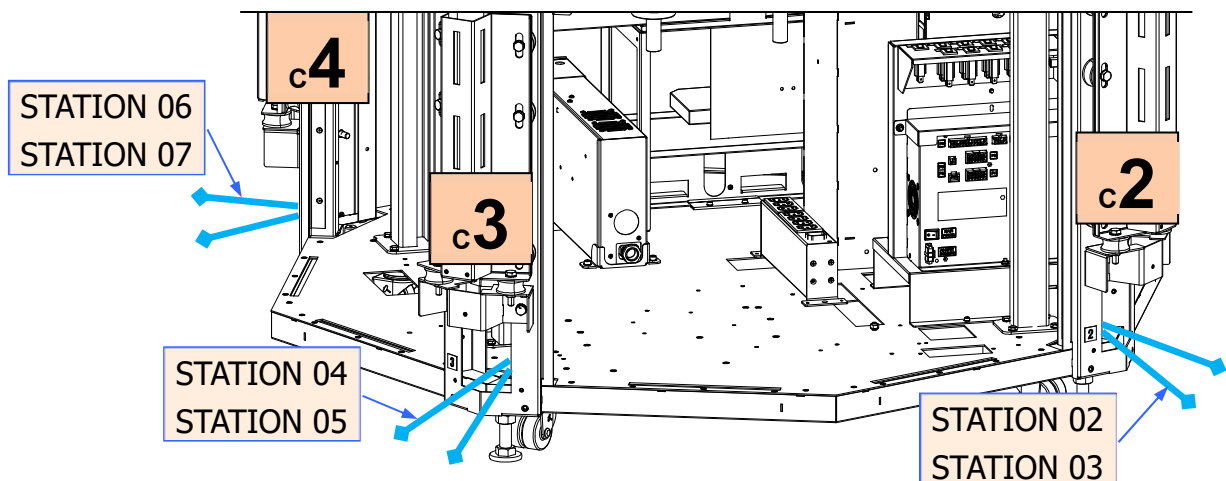

4. Prepare the following Parts.

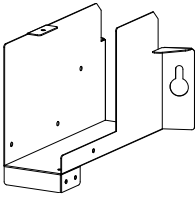
Parts Name	Qty	Appearance
Harness BRKT	2	

5. Affix the Harness BRKT to the feet of Corner 1 and of Corner 2 by using 2 screws on each. Pass the AC Cable of the side of the Corner 1 and the LAN Cable of the side of the Corner 2, behind the Harness BRKT.

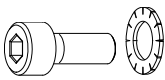
Fasteners	Qty	Appearance
C HEXAGON SOCKET M4x10 DIN 912 SERRATED LOCK WASHER 4 DIN 6798	4	

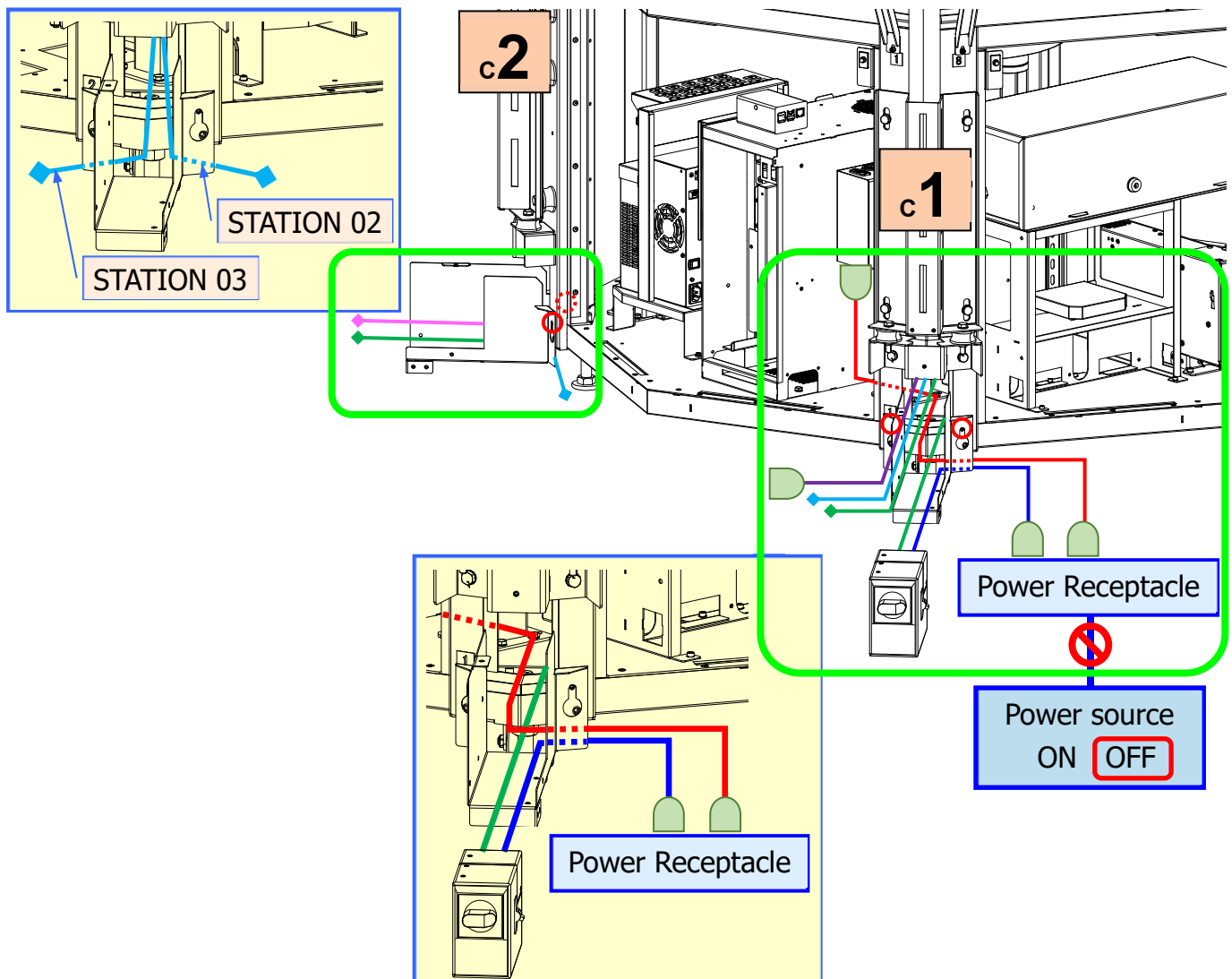

6. This completes the connection to the Power Source of Center Unit. Close the Security Cage Door, and return the Center Unit Doors to their original location, to connect the Stations. Arrange the cables installed so that they will not be an obstacle to the further procedures.

**⚠ CAUTION!**

Make sure that the 2 Switches of the Main Power Unit inside the Center Unit and the one under the Power Relay Unit, are all switched to ON.

**Please leave this switch on ON and do not change its status.**

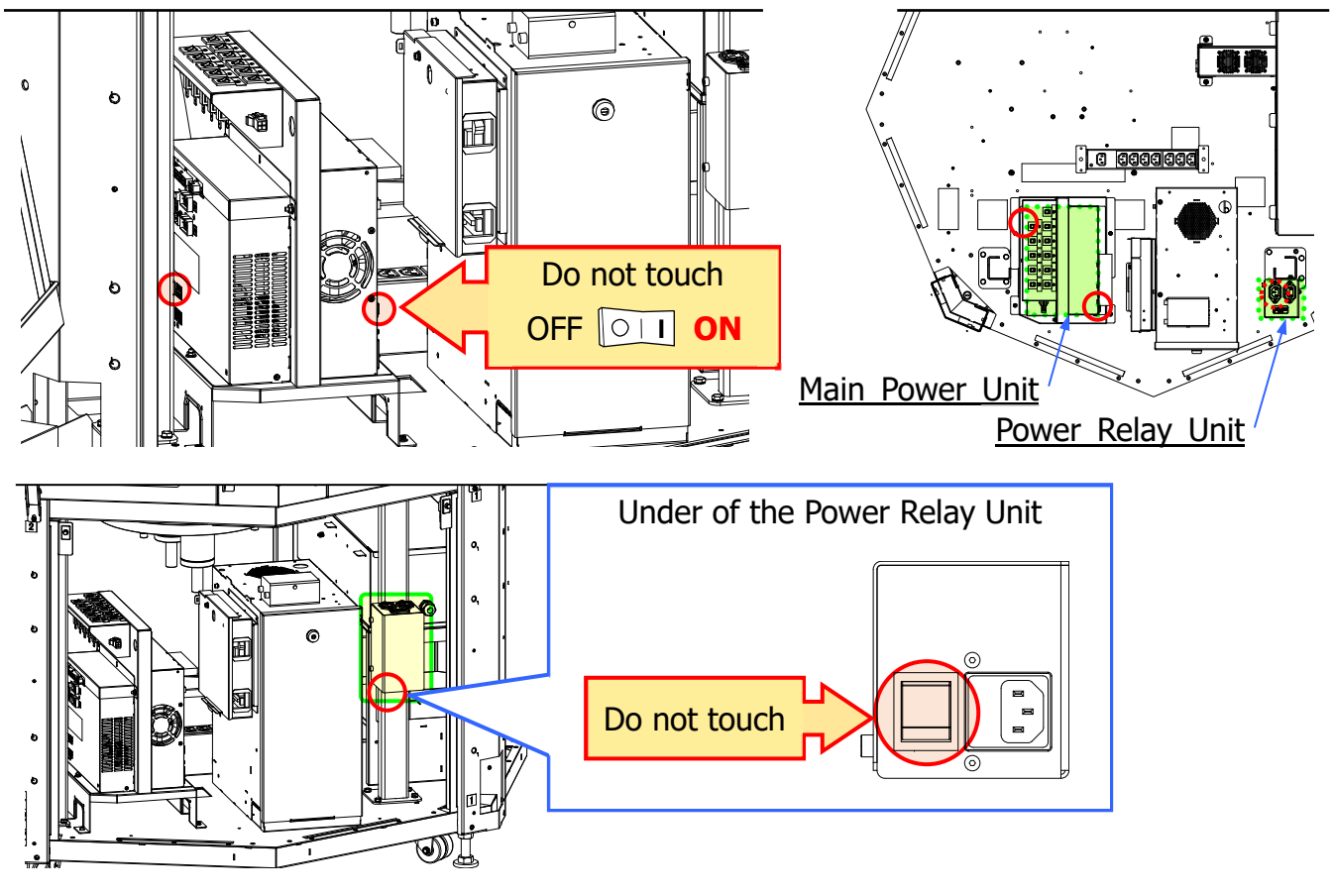

At this point the machine should look like this.

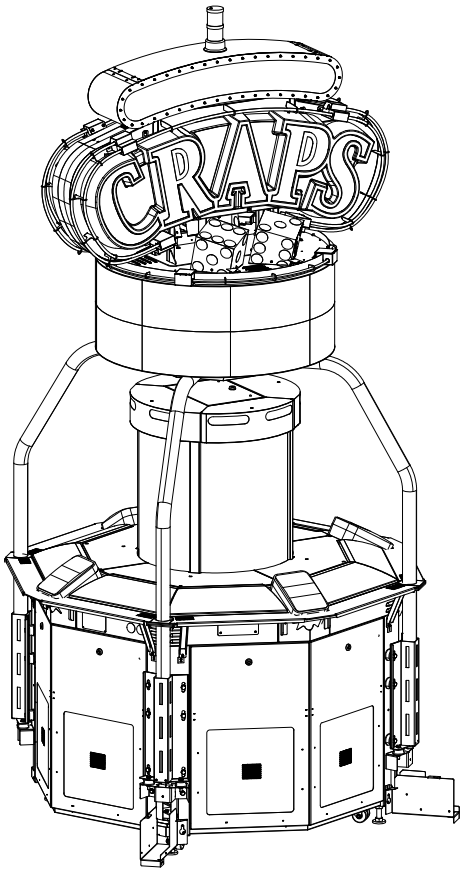

### 3. 2. 1. 9: Attaching the Pow Switch and HUB Spacer Unit and the Control Spacer Unit

1. Prepare the following Parts.

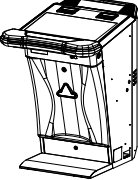
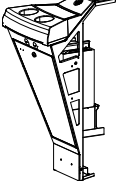
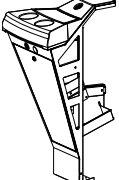
Parts Name	Qty	Appearance
Stations (STATION No.01 and No.03)	2	
Pow Switch and HUB Spacer Unit [RIGHT FILLER OF STATION No.01] (for Power Switch and HUB)	1	
Control Spacer Unit [RIGHT FILLER OF STATION No.03] (for AUDIT setting)	1	

2. Unlock and remove the Front Door and Bottom Door of each station.

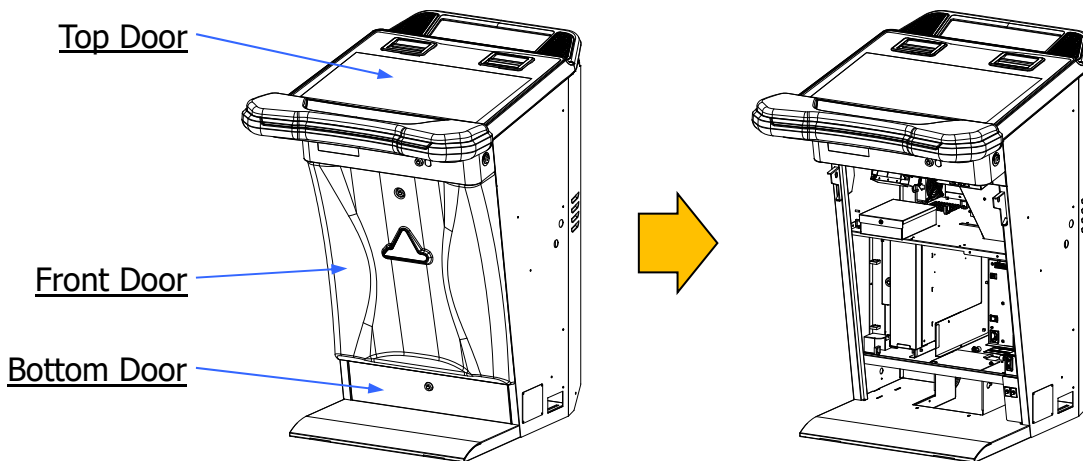

3. Affix the [RIGHT FILLER OF STATION No.01] to the right side of the [STATION No.01] by using 4 screws. This Station will become [Station 1 Unit].

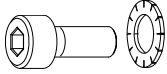
Fasteners		Qty	Appearance
C	HEXAGON SOCKET M4x10 DIN 912 SERRATED LOCK WASHER 4 DIN 6798	4	

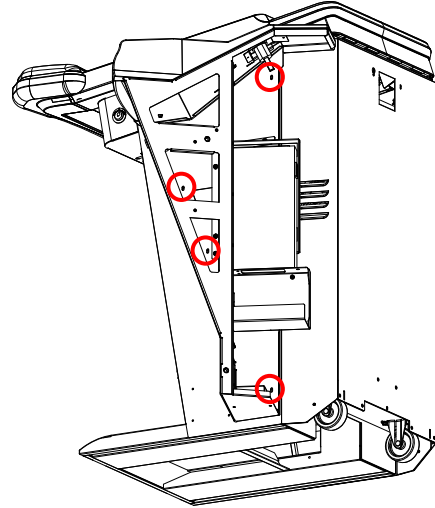
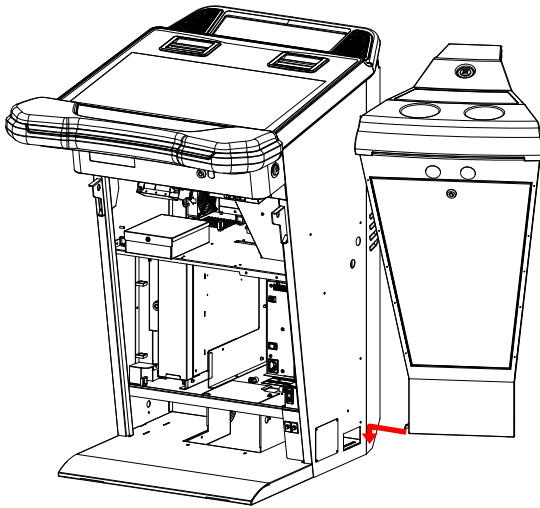

4. Affix the [RIGHT FILLER OF STATION No.03] to the right side of the [STATION No.03] by using 3 screws. This Station will become [Station 3 Unit].

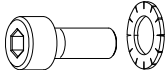
Fasteners		Qty	Appearance
C	HEXAGON SOCKET M4x10 DIN 912 SERRATED LOCK WASHER 4 DIN 6798	3	

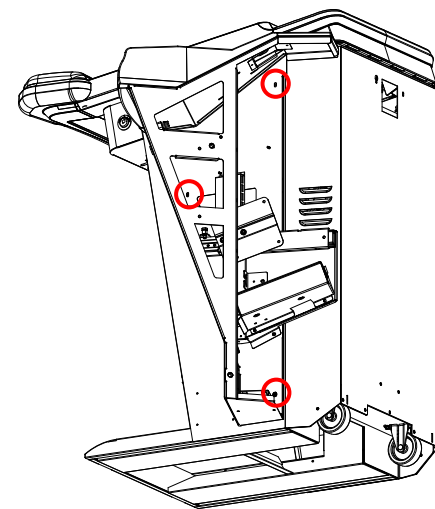
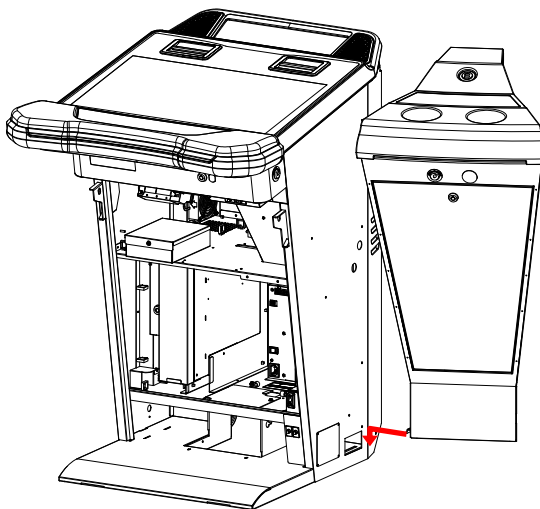

5. Unplug the [BL] connector connected to the inside of the station. Push inside the Station the [BLR] and [OPW] connectors located inside each Spacer Unit, through the opening on the lateral side, and connect them to the [BL] and [OPW] connectors of the Station.

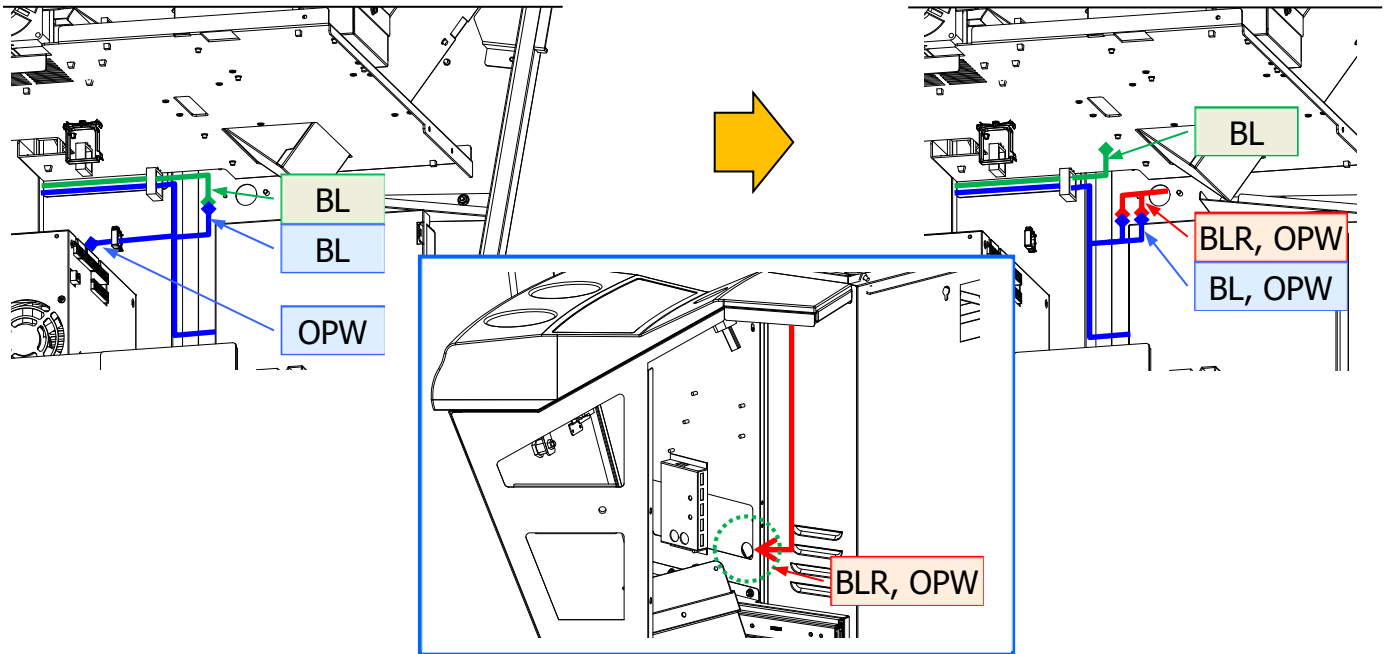

**- Control Spacer Unit only -**

- A) Unlock and remove the Control Spacer Door. Remove one screw to rise the Stopper, then draw the LCD Control Pad until the Stopper Pin locks, and secure the Slide Arm.

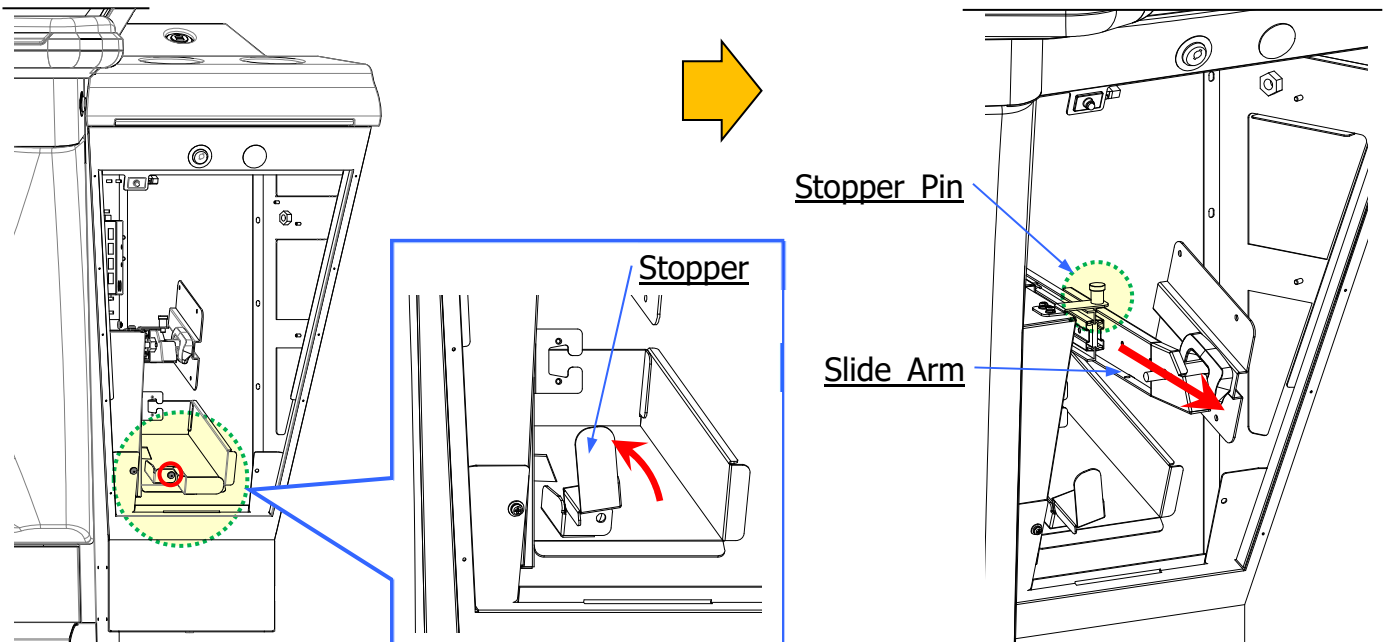

B) Prepare the following Parts.

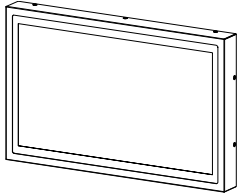
Parts Name	Qty	Appearance
LCD Control Pad (for Control Spacer Unit)	1	

C) Align the LCD Control Pad and the LCD BRKT of the Slide Arm as illustrated below, then affix it by using 4 screws.

Fasteners	Qty	Appearance
B HEXAGON SOCKET BUTTON with FLANGE M4x8	4	

**i NOTE:**

Before installing the LCD Control Pad, turn the LCD BRKT as illustrated.

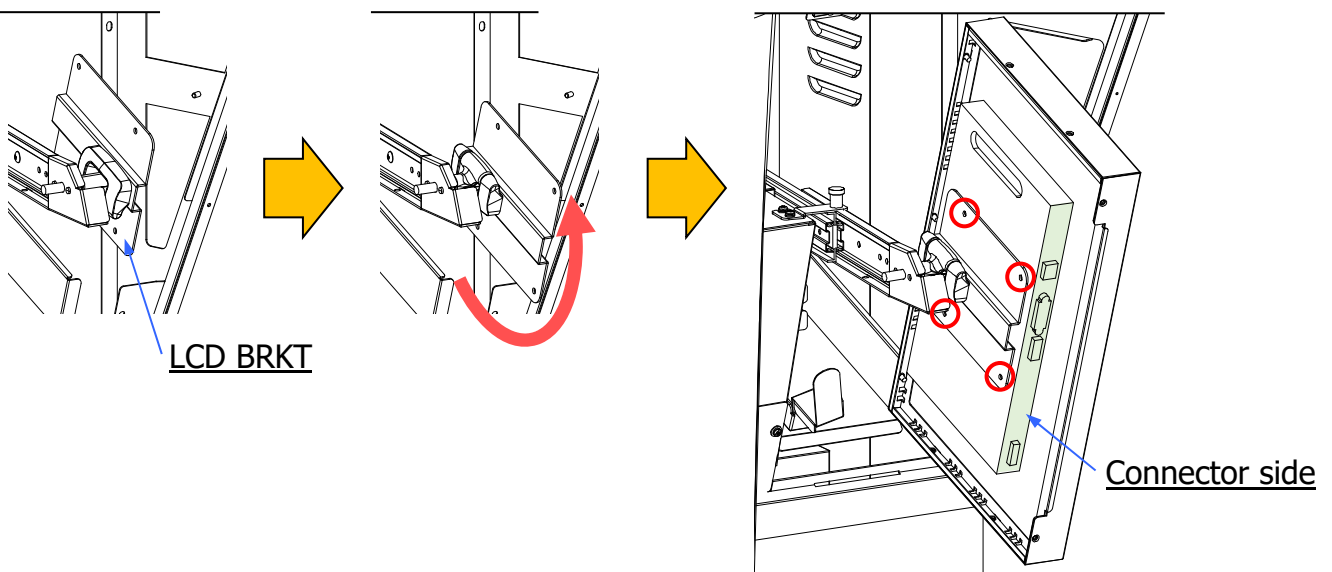

- D) Plug the [P12V], [DP] and [USB] Connector mounted on the Slide Arm, to the Connecters of the LCD Control Pad.

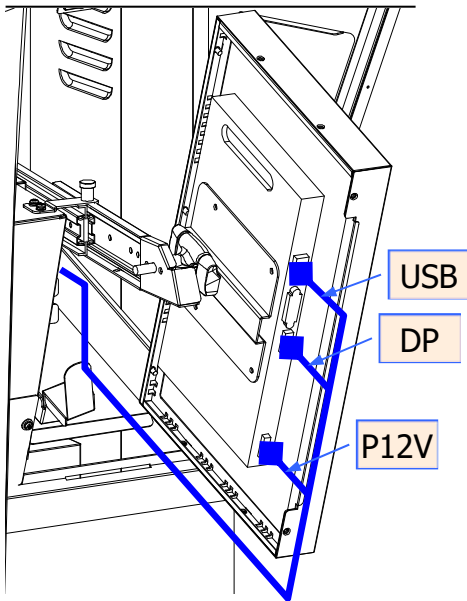

- E) Rotate the LCD Control Pad following the arrows as shown by the illustration below, to the position for storing, while paying attention to the connected cables.

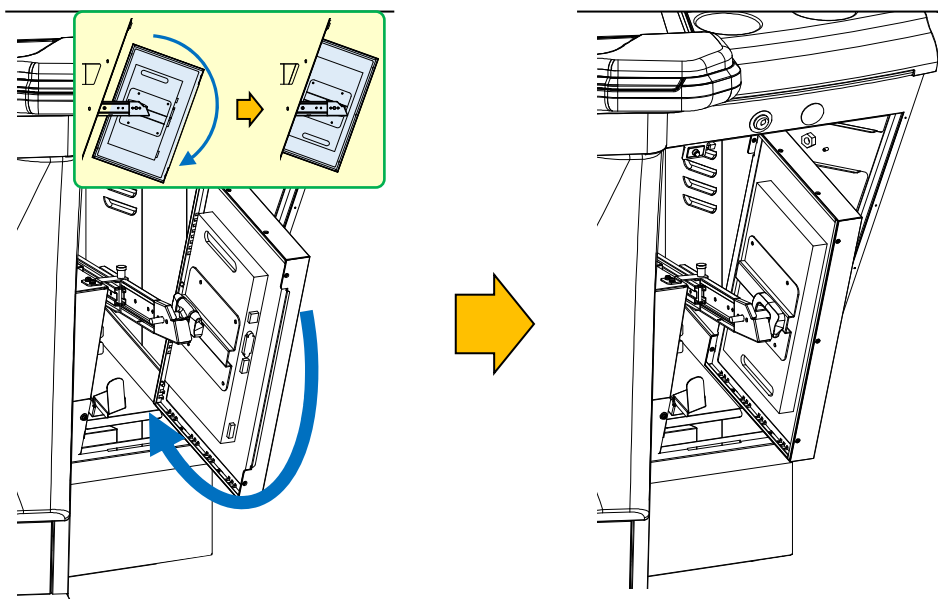

F) Push in the LCD Control Pad keeping the Stopper Pin pulled up, then lower the Stopper.

**CAUTION!**

Pay attention not to pinch the cables.

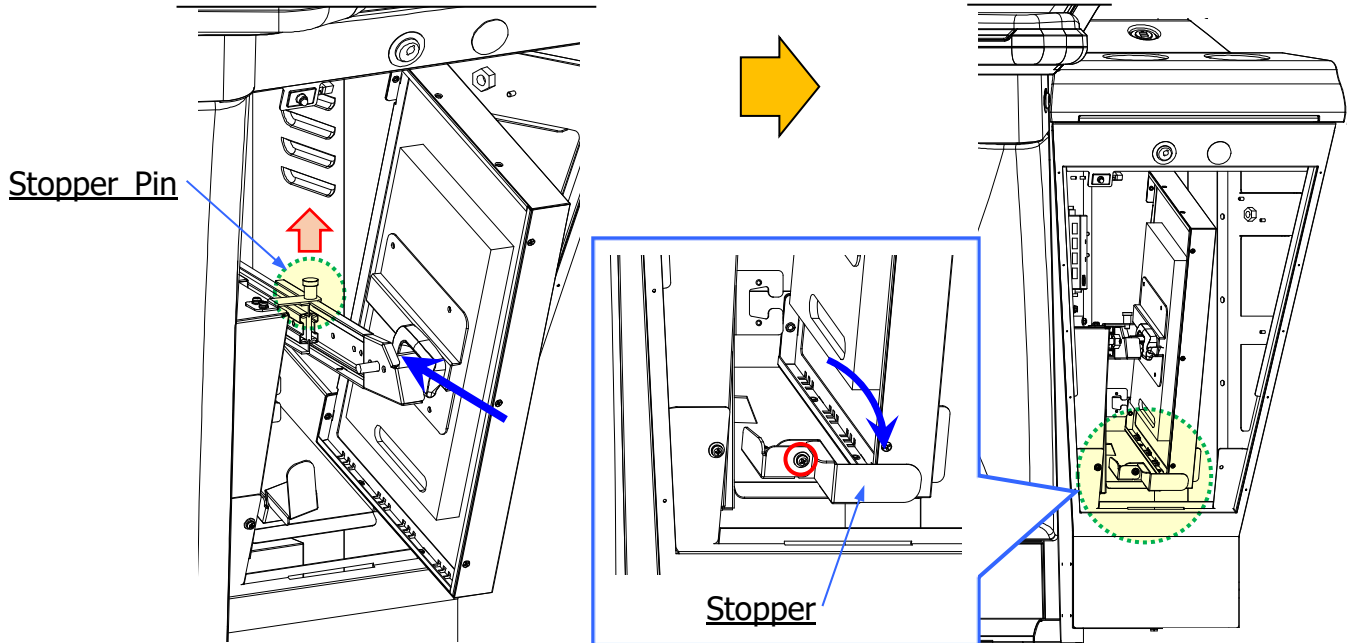

### 3. 2. 1. 10: Installing the Control Spacer Unit to Center Unit

1. Move the [Station 3 Unit] closer to side labelled by the sticker [STATION No.03].

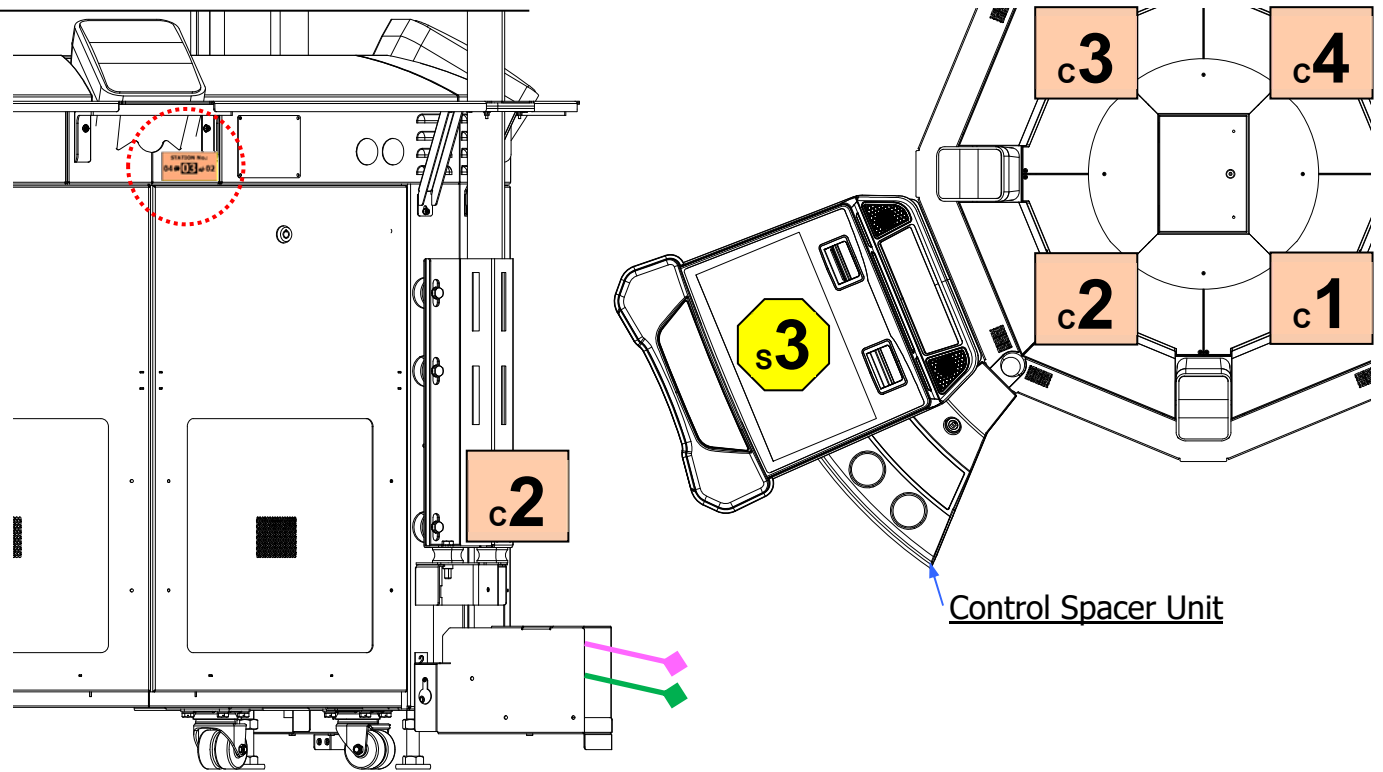

2. Connect the [D1], [12V] Connectors from the Center Unit (**Refer to STEP 3 of 3.2.1.5**) to the [D1], [12V] Connector of the [Control Spacer Unit].

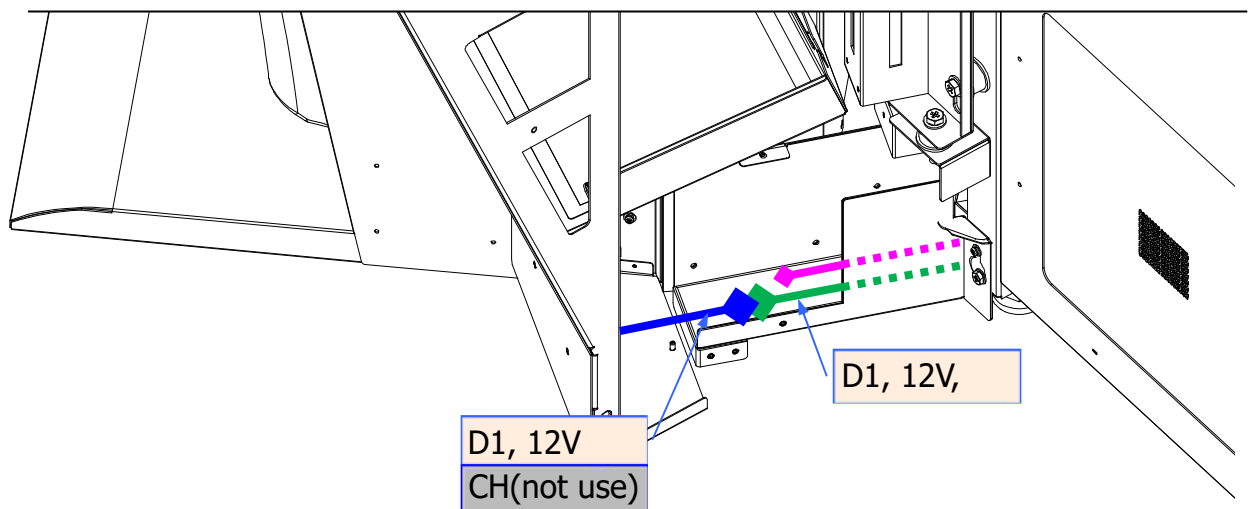

3. Connect the [DP] and the [USB] Connecters from the Center Unit (**Refer to STEP 3 of 3.2.1.5**) to the 2CH KVM Switch of the [Control Spacer Unit].

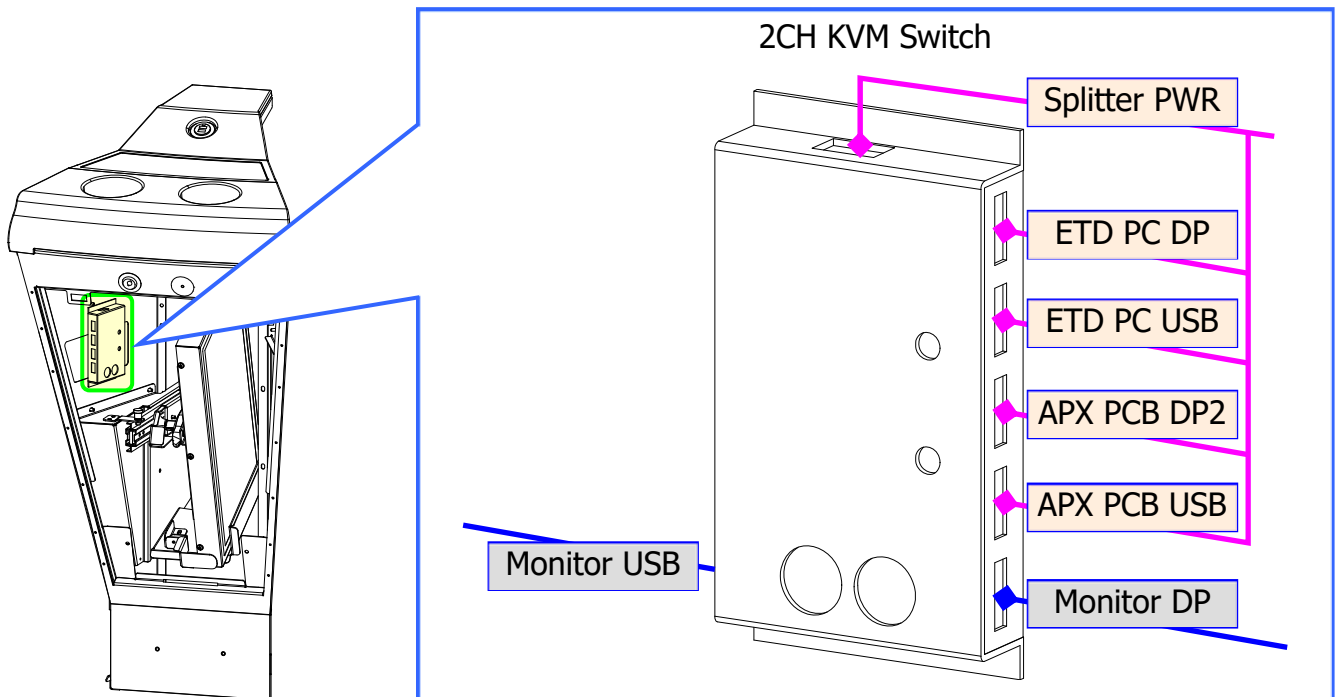

4. Insert the [STATION 03] LAN Cable (**Refer to STEP 3 of 3.2.1.8**), at the bottom of the rear side of the [STATION No.03].

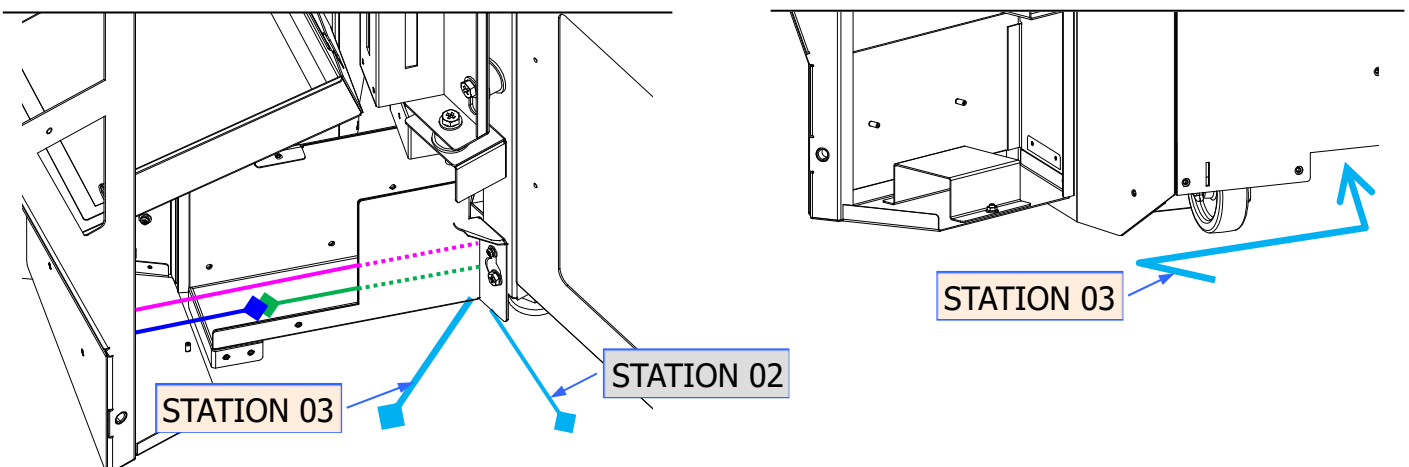

**i NOTE: Option-[If using a USB Charger]**

Insert the AC Adapter of the AC Cable for the USB Charger, at the bottom of the rear side of the Station.

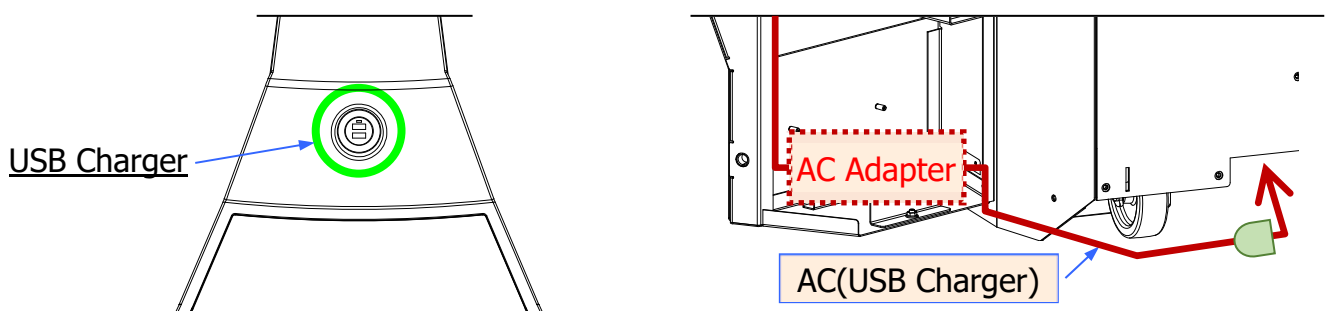

5. Remove 1 screw and detach the Bottom Cover of the [STATION No.03].

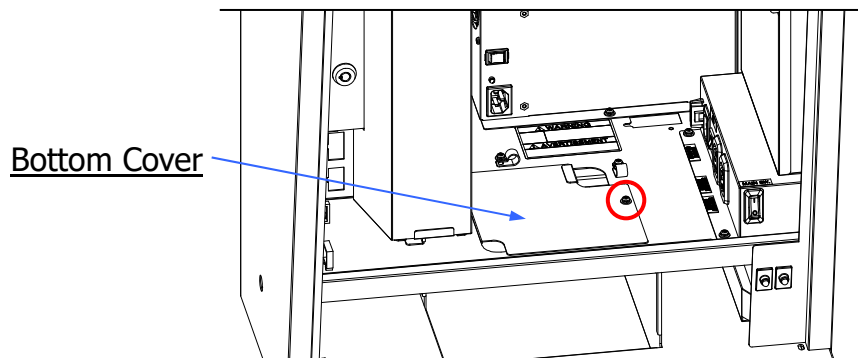

6. Unlock the Security Cage Front Cover and connect the [STATION 03] LAN Cable to the [LAN 2] Port indicated below.

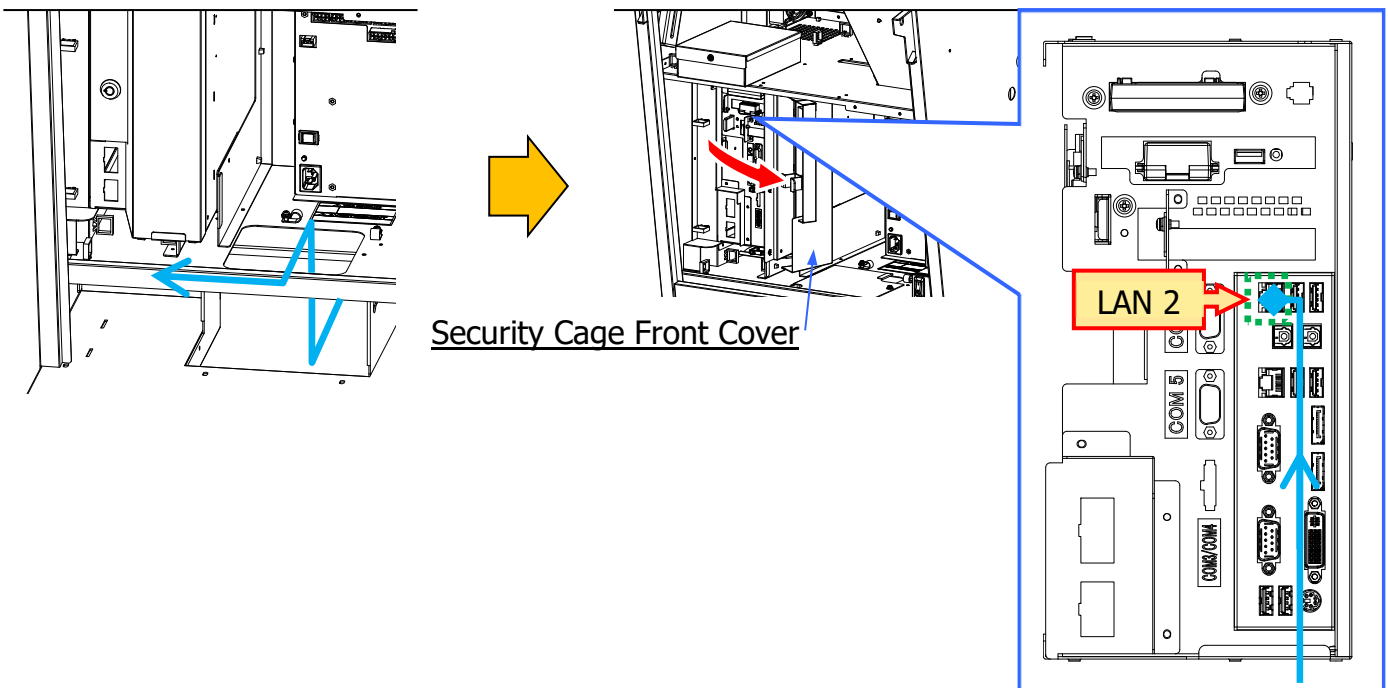

7. Prepare the following Parts.

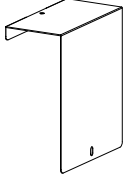
Parts Name	Qty	Appearance
Harness Cover	1	

8. Affix the Harness Cover to the Harness BRKT by using 2 screws, while paying attention not to pinch the Cables.

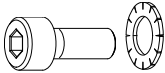
	Fasteners	Qty	Appearance
C	HEXAGON SOCKET M4x10 DIN 912 SERRATED LOCK WASHER 4 DIN 6798	2	

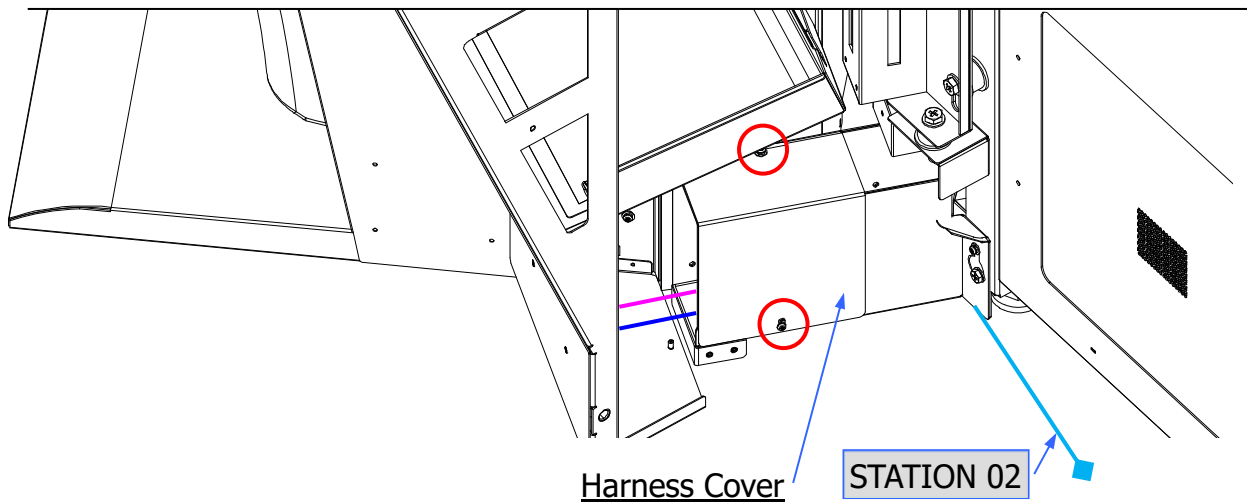

### 3. 2. 1. 11: Installing the Pow Switch and HUB Spacer Unit to Center Unit

1. Move the [Station 1 Unit] closer to side labelled by the sticker [STATION No.01].

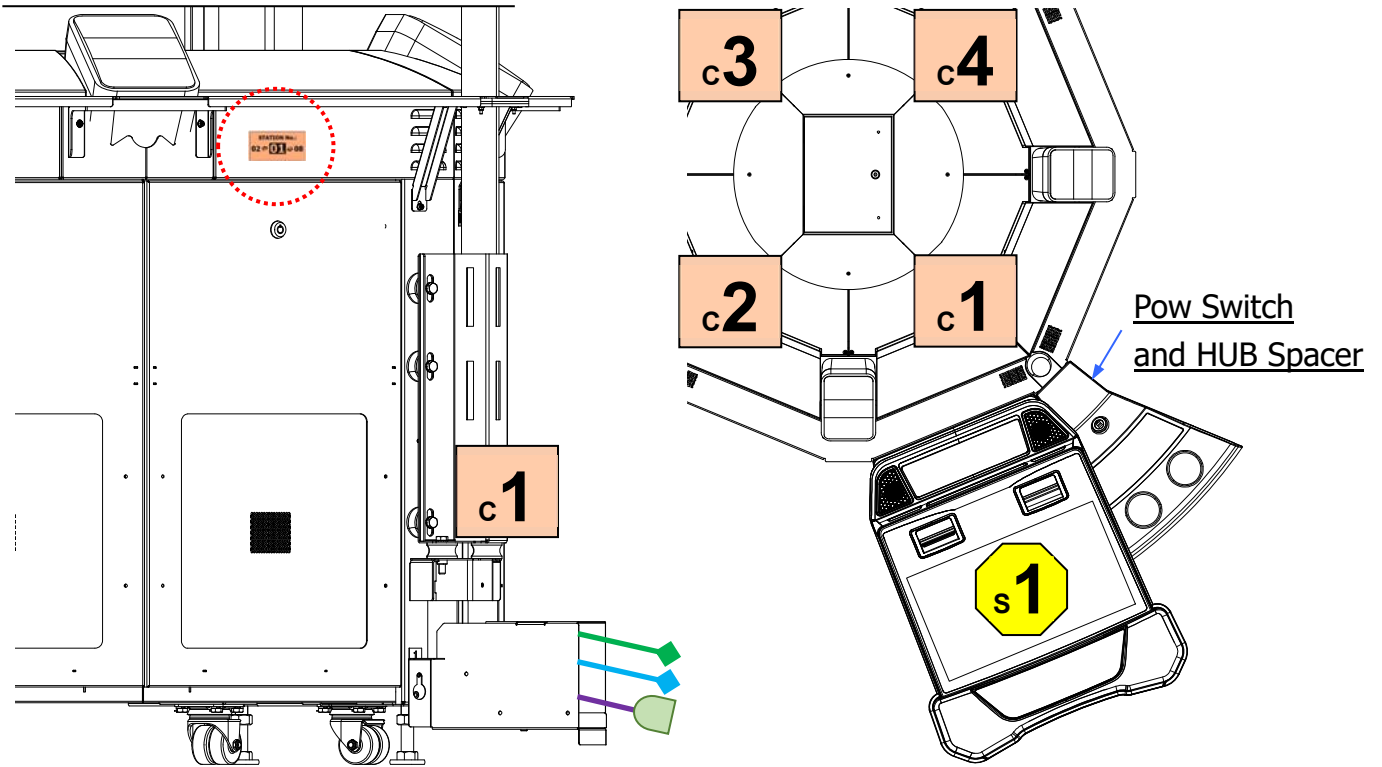

2. Unlock and detach the Pow Switch and HUB Spacer Door. Install the Main Power Switch (Refer to 3.2.1.7) on the BRKT of the Pow Switch and HUB Spacer as illustrated below.

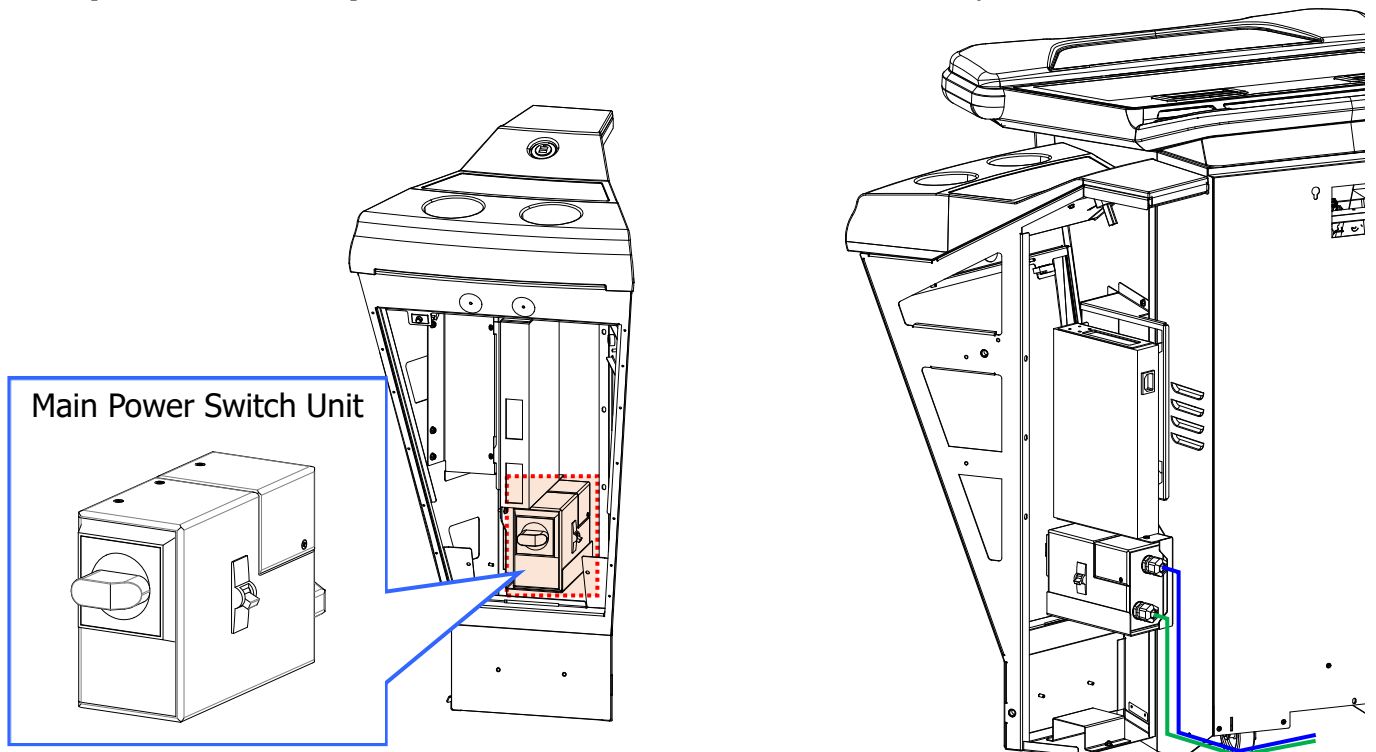

3. Connect the [D2] Connector from the Center Unit (**Refer to STEP 2 of 3.2.1.5**) with the [D2] Connector of the [Pow Switch and HUB Spacer Unit].

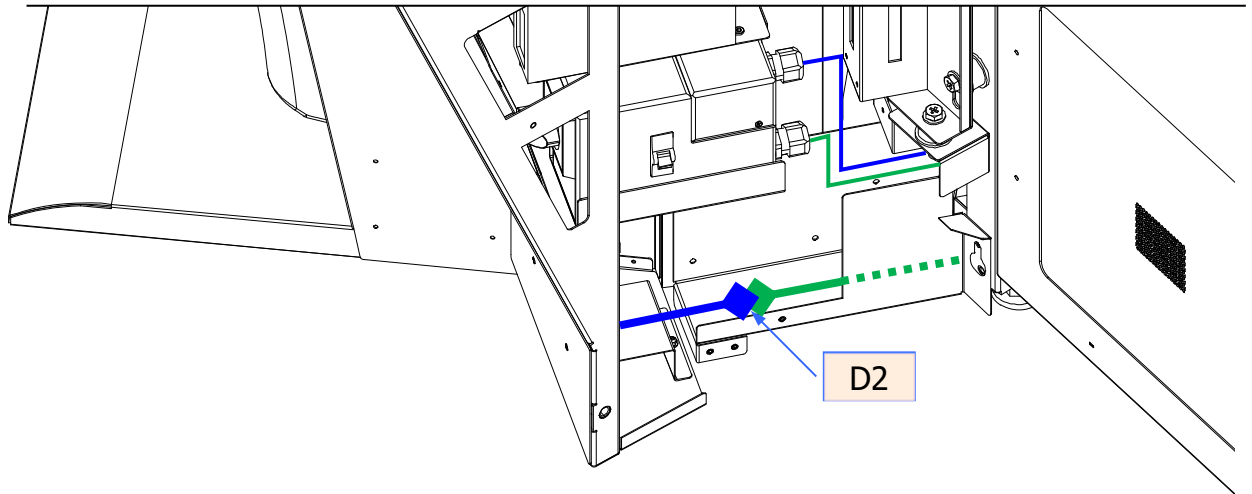

4. Connect to the HUB the AC Cable (for HUB Unit) from the Center Unit (**Refer to STEP 1 of 3.2.1.8**), and the 9 [LAN] Cables (**Refer to STEP 2 of 3.2.1.8**).

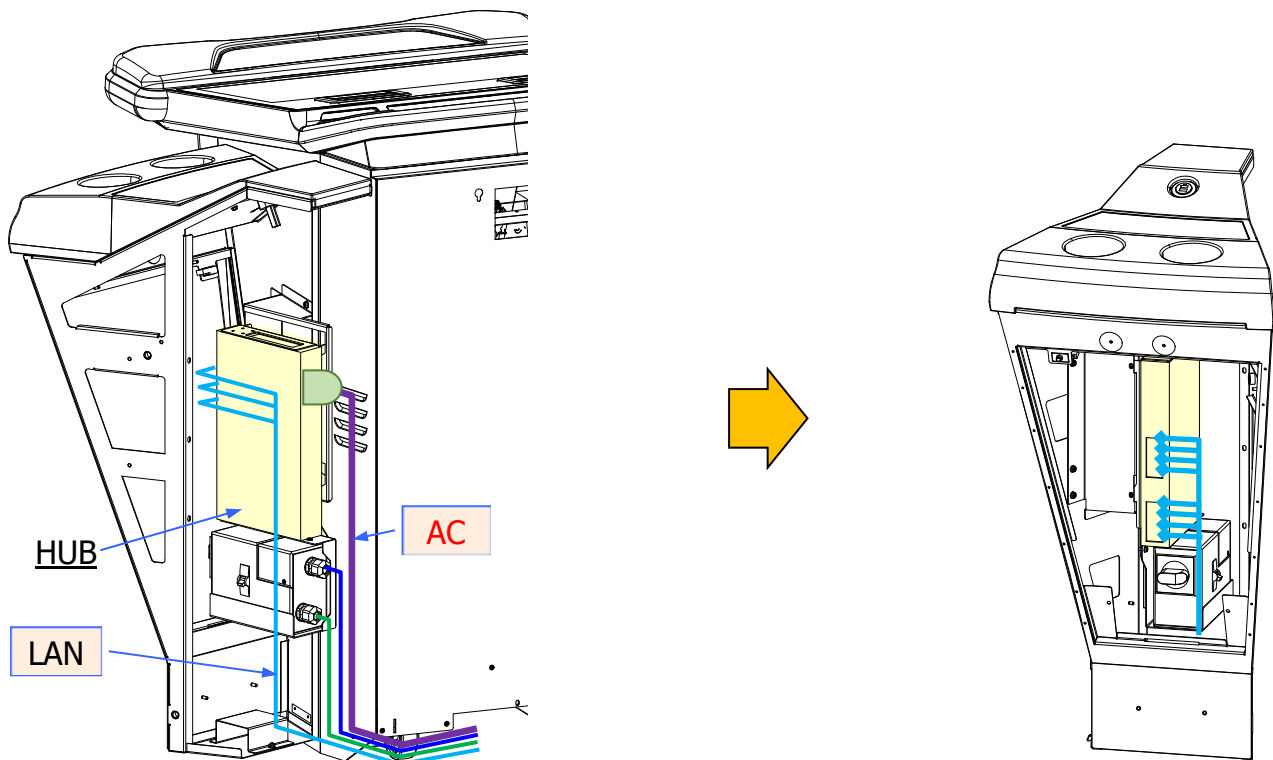

5. Remove 1 screw and detach the Bottom Cover of the [STATION No.01].

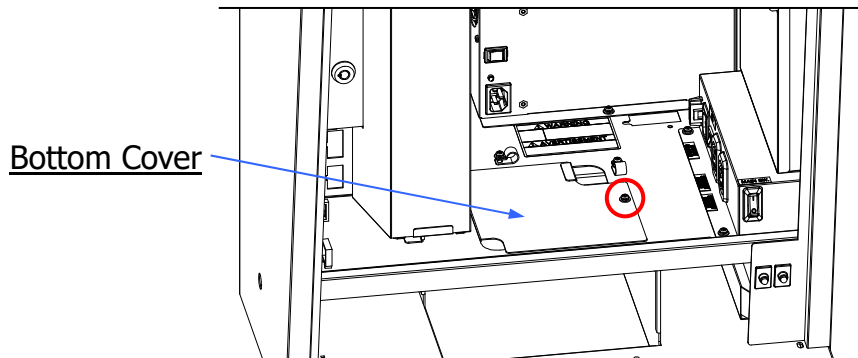

6. Prepare the following Parts.

Parts Name	Qty	Appearance
LAN Cable(for Station: 2.5m)	1	

7. Unlock the Security Cage Front Cover and connect the [LAN] Cable to the [LAN 2] port indicated below, then pull the opposite head out from the station.

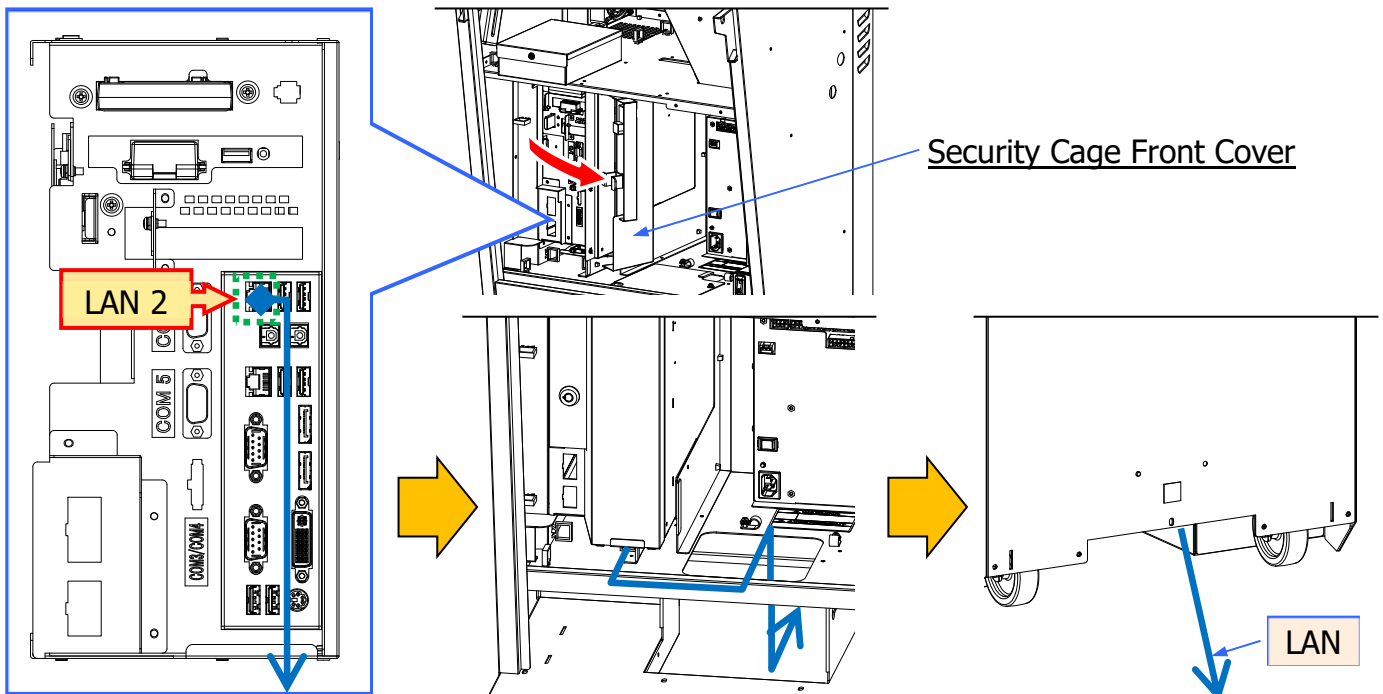

8. Connect [LAN] cable that was pulled out at STEP 7, to the Port of the HUB.

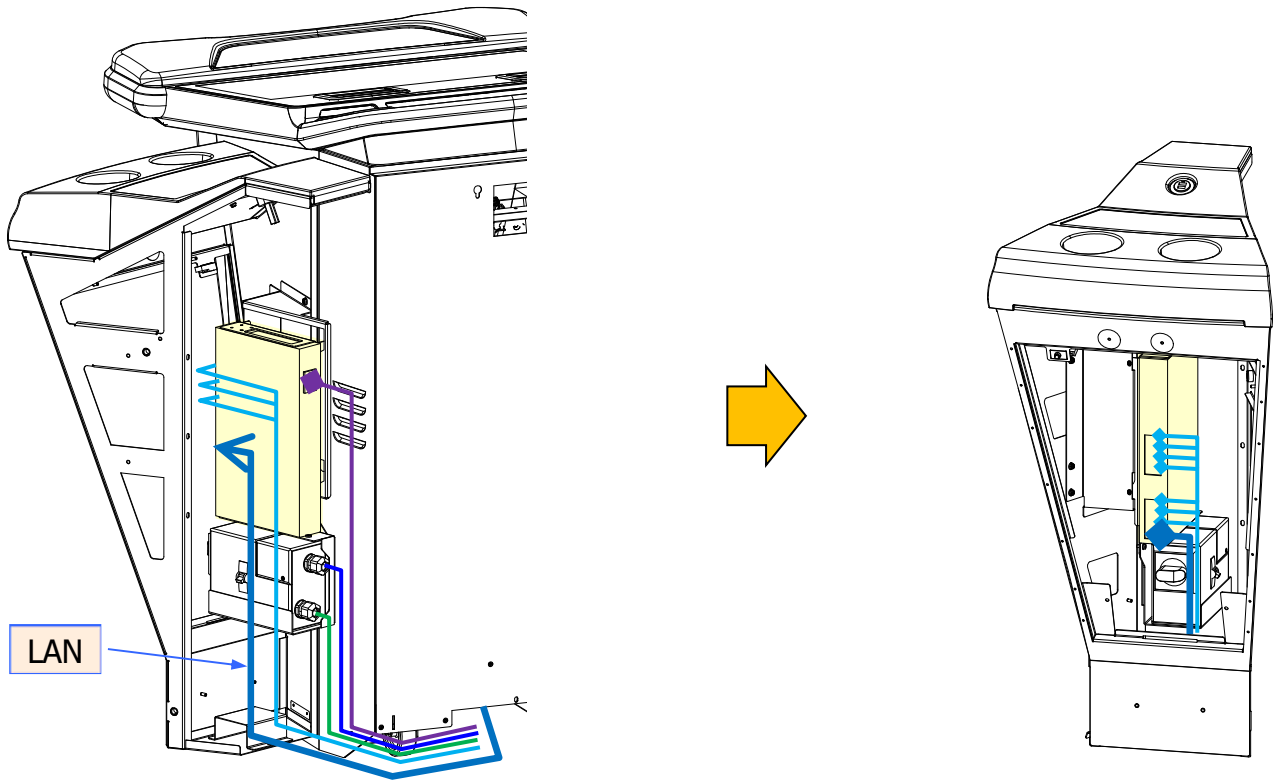

**i NOTE: Option-[If using a USB Charger]**

Insert the AC Adapter of the AC Cable for the USB Charger, at the bottom of the rear side of the Station.

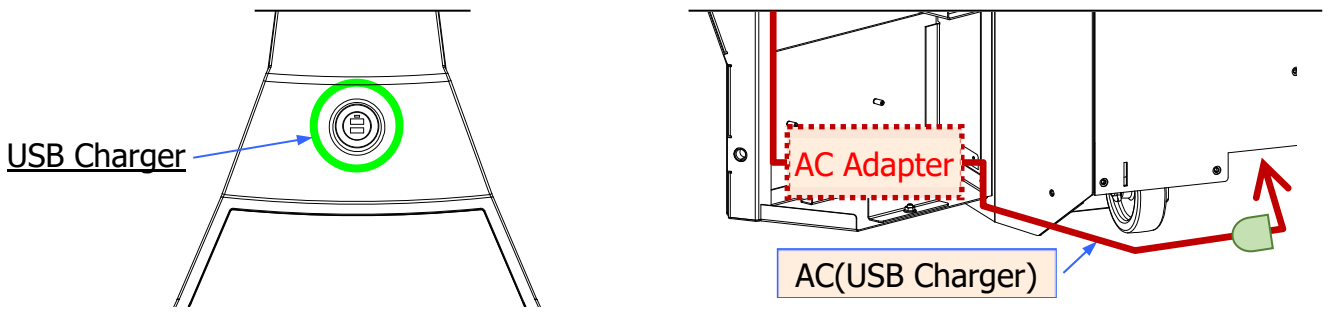

At this point the machine should look like this.

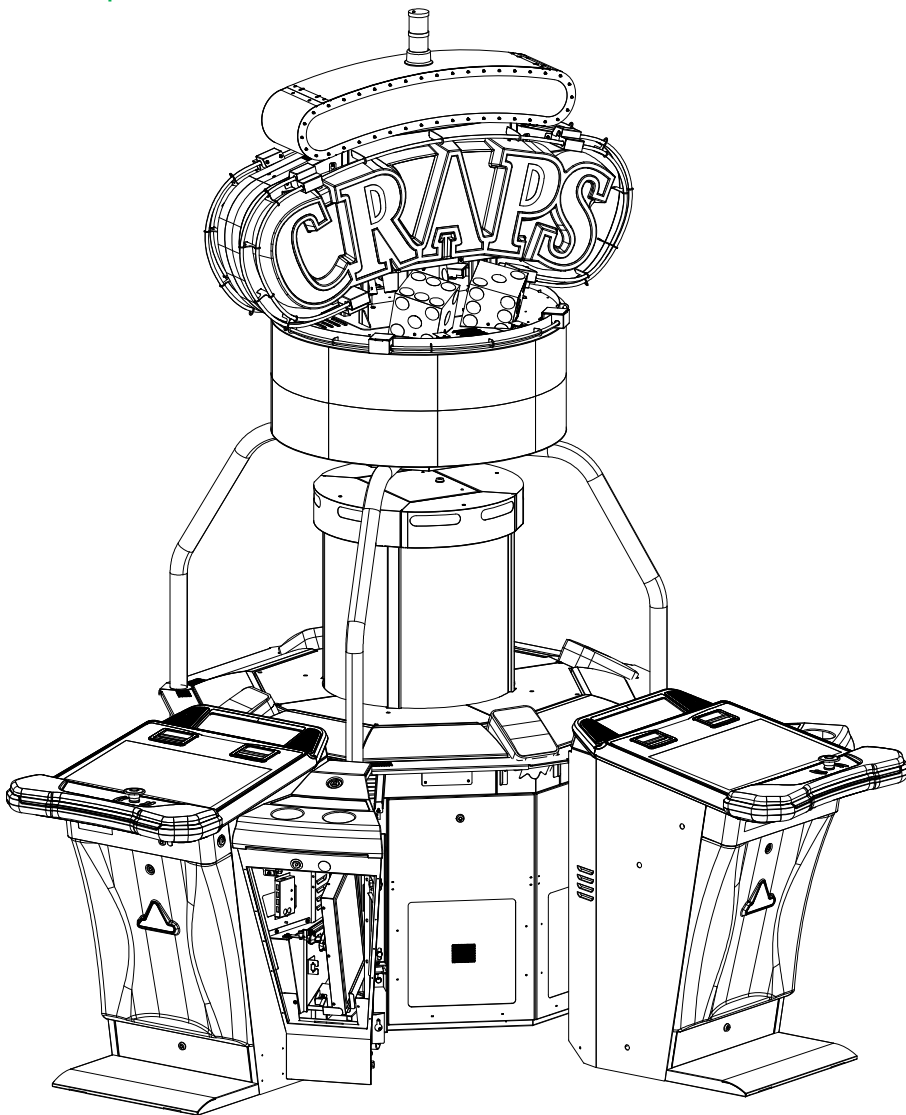

### 3. 2. 1. 12: Checking Operation of the Center Unit

Please do a functionality of the Center Unit before installing the remaining Station Units, to check if the procedures up to now were correct.

Before turning ON the Center Unit, check the following:

- All the cable connectors are securely seated.
- The machine is properly earthed.

1. Set the LCD Control Pad to the operating position (Refer to Chapter 2.1 on SERVICE Manual).

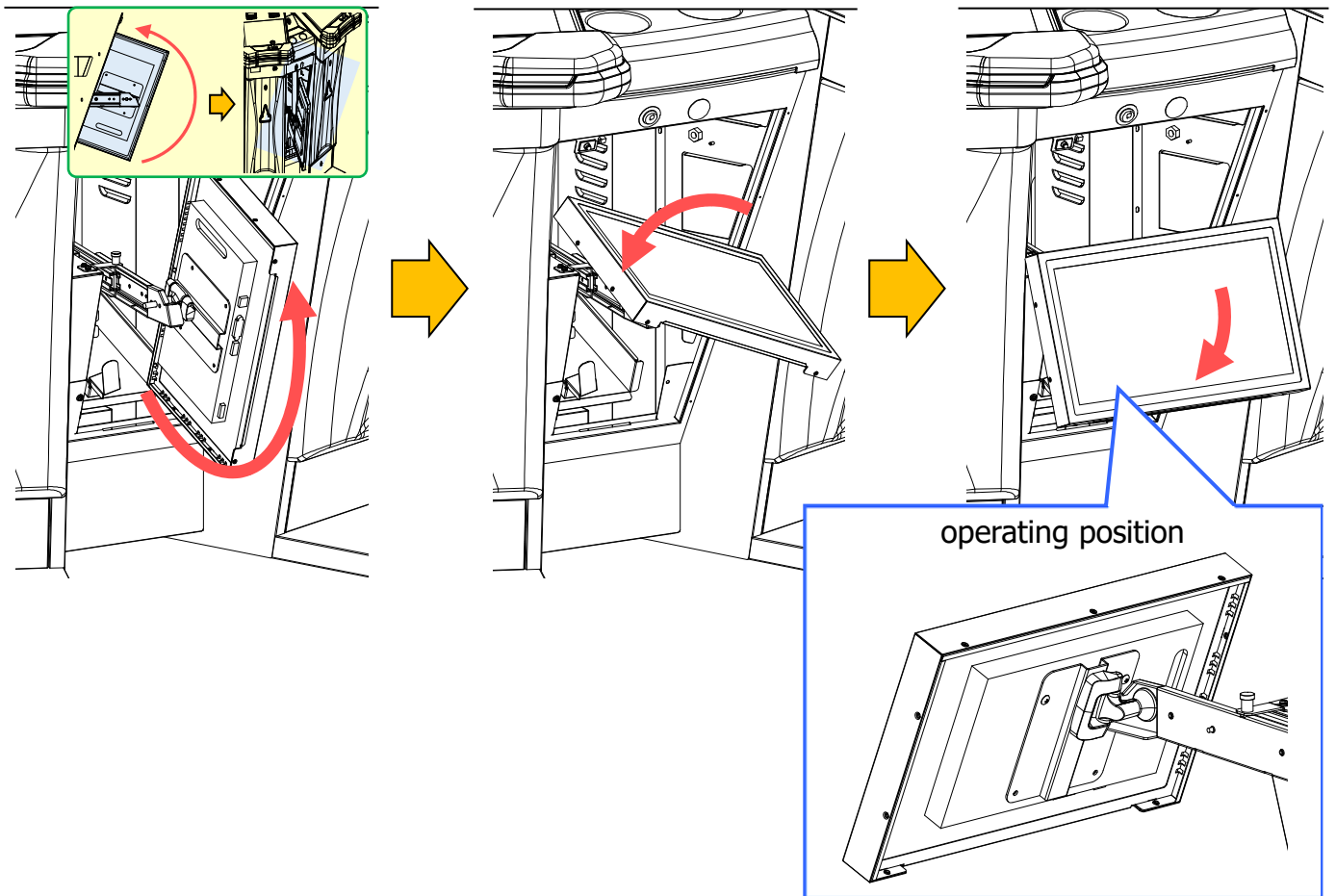

2. First turn ON the power source. The devices directly connected to the power source will boot up.

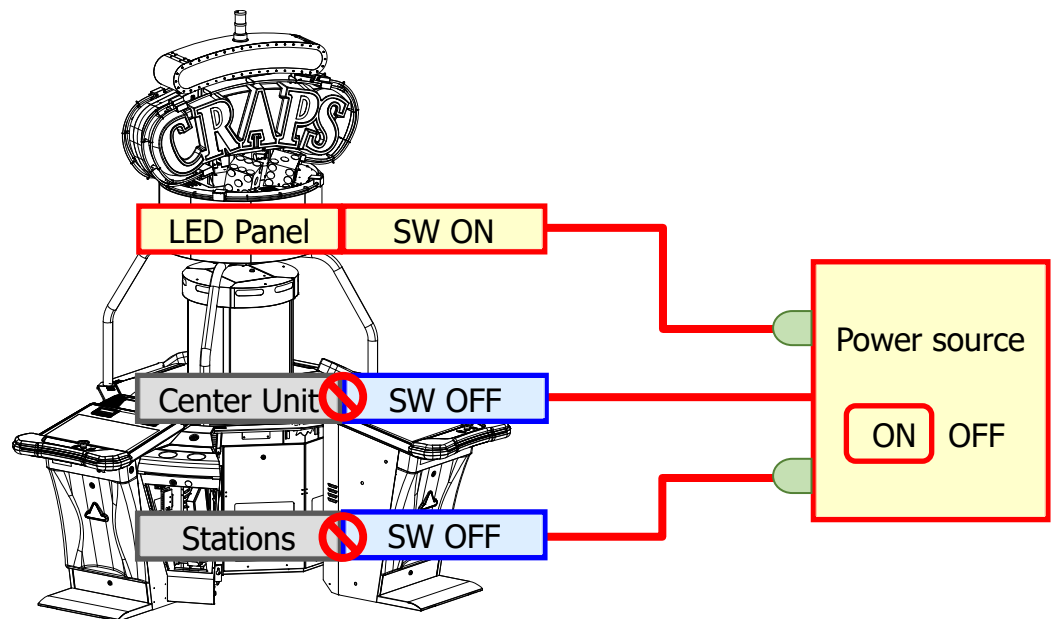

3. To change the AUDIT settings of the Center Unit, unlock and remove the Security Cage Door inside the Center Unit.

**⚠ CAUTION!**

For specific jurisdictions, to configure **"IMPORTANT SETTING (BASIC SETTING)"** a Setting GAL Cassette and a Setting Password are necessary. Refer to **"Configuring Settings by using a Setting GAL :for NEVADA/ARIZONA"** on chapter 6 of the SERVICE Manual to configure these settings, and after that proceed with the operations from STEP 10 of this chapter.



4. Turn to ON the Power Switch of the Center Unit.

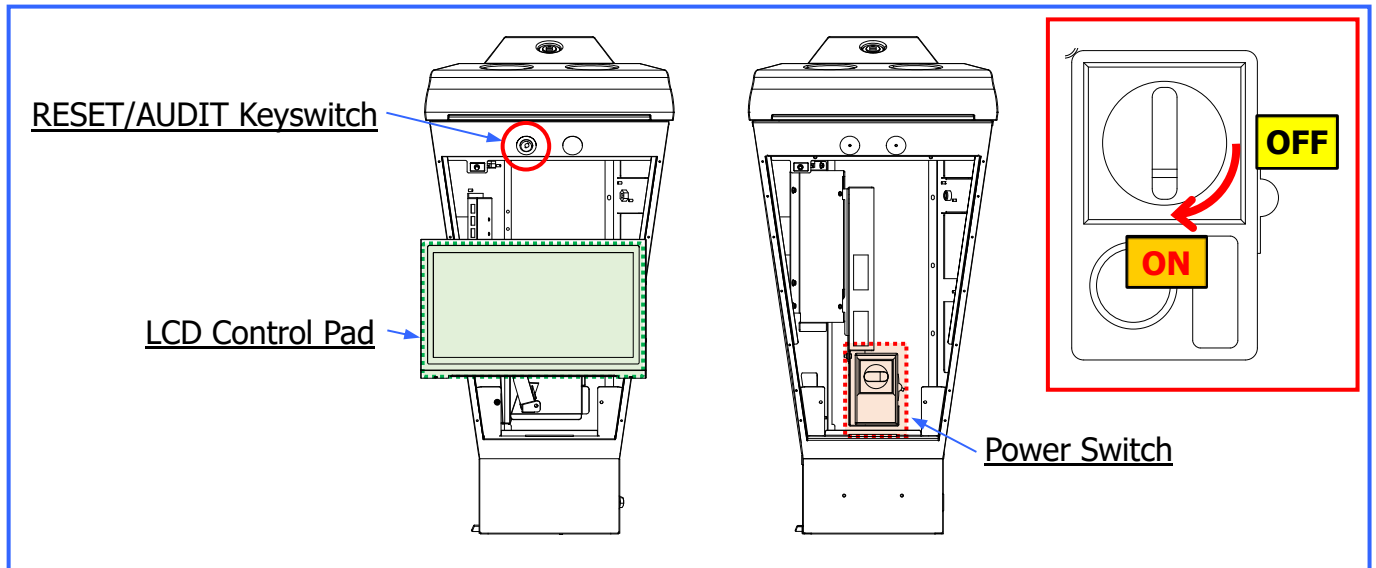

**CAUTION!**

When doing "Power OFF-ON" wait at least 15 seconds before power On.

**NOTE:**

- If an error appears during the POWER UP SELF TEST, the activation of the Machine halts. Refer to OPERATION Manual Chapter 8 "**Error Messages**" to clear it.
- If it is necessary to perform the RAM Clear (Memory Clear), refer to "**Memory Clear Procedure**" on Chapter 6.

- ◇ Are there any strange sounds or smells coming from the machine?
- ◇ Test the proper functionality of Sensors, RESET/AUDIT key switches etc.

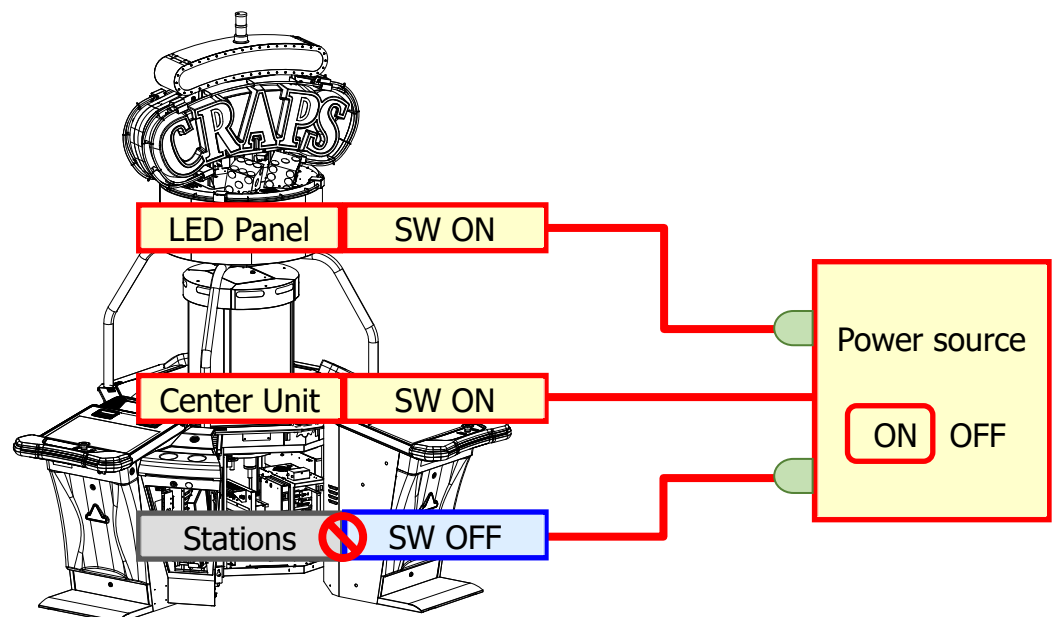

- To call the AUDIT mode, turn the key to the AUDIT position, and return it to the neutral position.



- Refer to "**Version Information**" at Chapter 6 of the OPERATION Manual, to check that the Software version is the same as the Software Version approved for installation.
- Refer to "**Settings**" on Chapter 4 of the SERVICE Manual to configure the necessary settings.
- When settings are complete, press [Exit] or [RETURN TO...] on the menu screen. When the following message appears: [Touch [YES] to SAVE the Update. to CANCEL the Update, touch [NO].], press [YES].  
When the [Turn OFF and ON the machine to make the Update effective.] message appears, turn OFF the machine.
- Close the Security Cage Doors and return the Center Unit Doors to their original position.

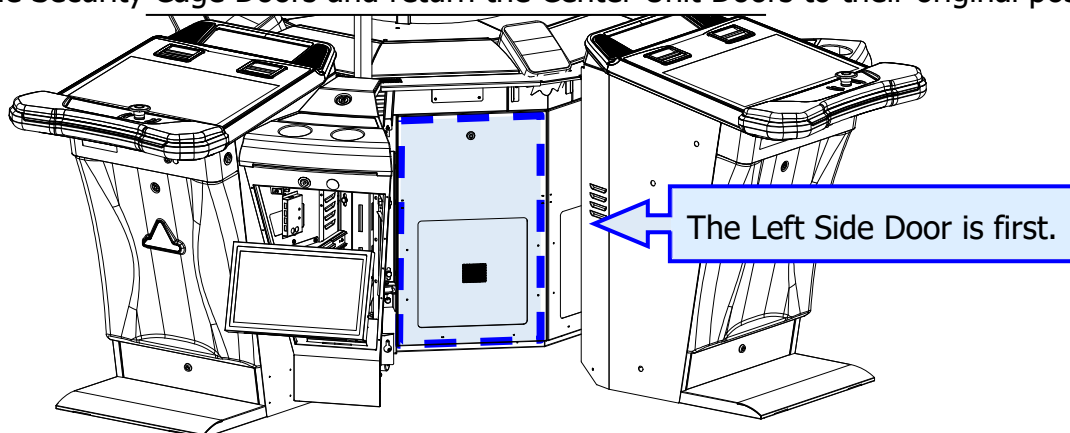

- Turn ON again the Power Switch of the Center Unit.

**CAUTION!**

When doing "Power OFF-ON" wait at least 15 seconds before power On.

- To call the AUDIT mode, turn the key to the AUDIT position, and return it to the neutral position.

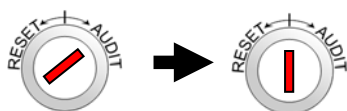

12. Refer to "NUMBER OF STATIONS" on "**Extra Settings**" at Chapter 4 of the SERVICE MANUAL, to set the total number of the Stations.

**i NOTE: Option-**[In case it is planned to extend the number of stations]

Set the total number of the stations, including the extension. (Ex: if 4 stations are added to the [original] 8, set  $8+4=[12]$ ).



13. Refer to "**Live Camera Test**" at Chapter 4 of the SERVICE Manual, to check if the Live Camera Screen is displayed.
14. Refer to "**Output Test**" at Chapter 4 of the SERVICE Manual, to check if the illuminations are lit correctly.
15. Refer to "**Sound Test**" at Chapter 4 of the SERVICE Manual, to check if the Game sounds are played correctly.

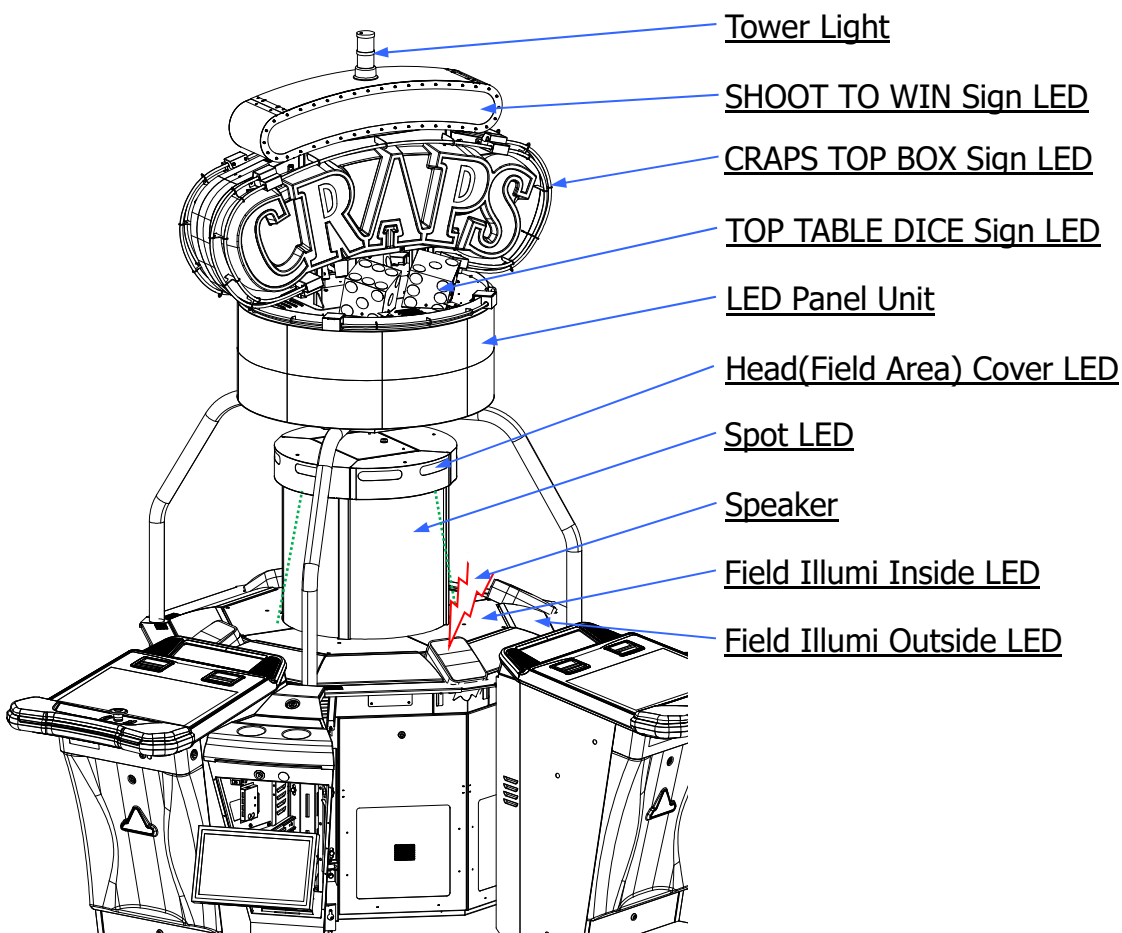

- Exit the AUDIT and store the LCD Control Pad (refer to Chapter 2.1 of the SERVICE Manual), then close the Control Spacer Door and the Pow Switch and HUB Spacer Door. Check if the announcements and the BGM play correctly. This concludes the functionality test on the Center Unit.

**i NOTE:**

If a "GAME FAILURE ERROR" error appears, clear the error by turning the key to the RESET position, and returning it to the neutral position.

Turn OFF the Power switch of the Center Unit and then turn OFF also the power source.

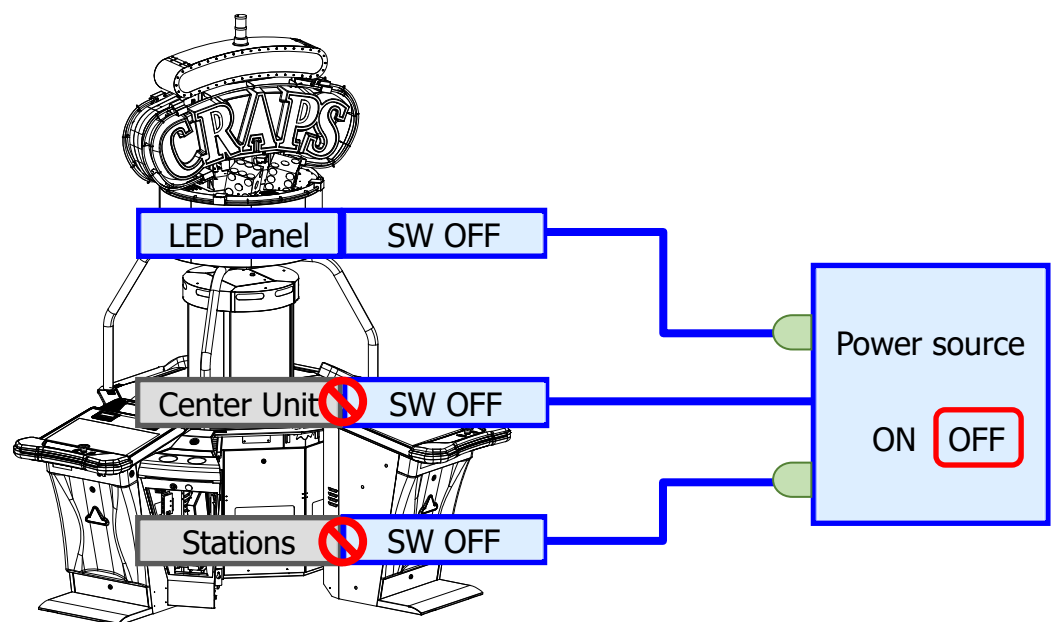

### 3. 2. 2: Stations

#### 3. 2. 2. 1: Attaching the Spacer Units for the other Stations

1. Prepare the following Parts.

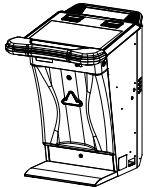
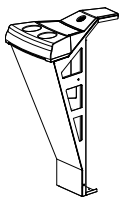
Parts Name	Qty	Appearance
Stations (STATION No.02, 04, 05, 06, 07 and 08)	6	
Spacer Units (RIGHT FILLER OF STATION No.02, 04, 05, 06, 07 and 08)	6	

2. Unlock and remove the Front Door and Bottom Door of each station.

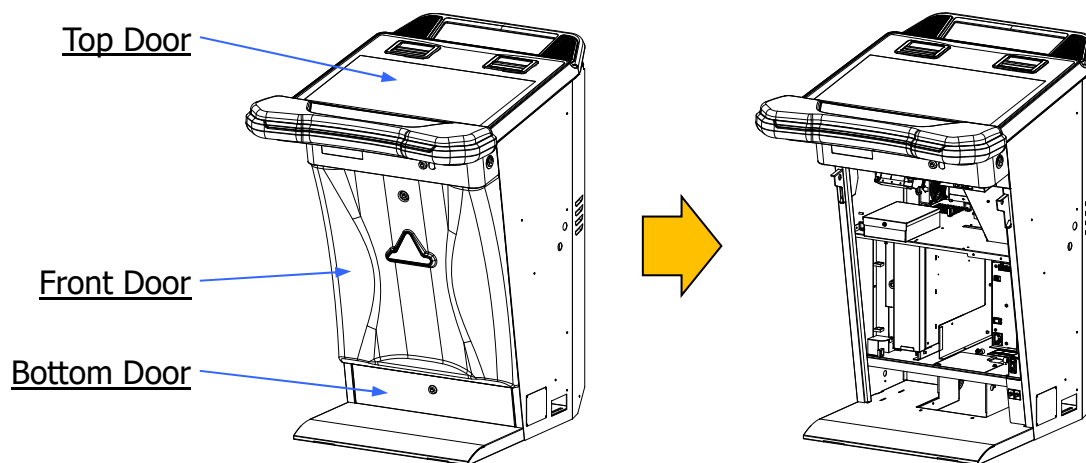

3. Affix the [RIGHT FILLER OF STATION No.x] to the right side of the [STATION No.x] by using 4 screws. The Station will become [Station x Unit].

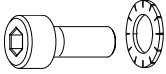
Fasteners		Qty	Appearance
C	HEXAGON SOCKET M4x10 DIN 912 SERRATED LOCK WASHER 4 DIN 6798	24	

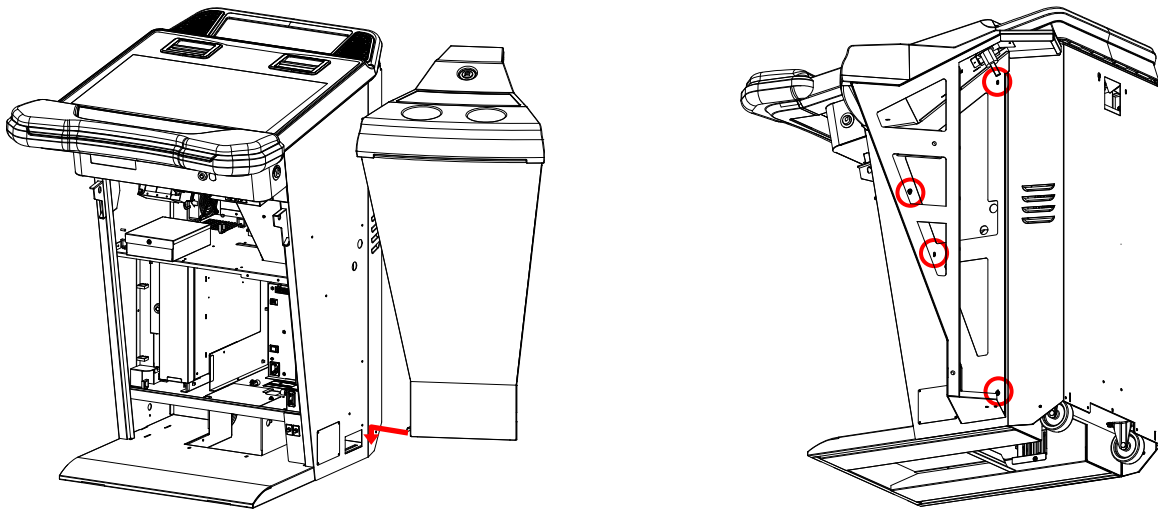

4. Unplug the [BL] connector connected to the inside of the station. Push inside the Station the [BLR] and [OPW] connectors located inside each Spacer Unit, through the opening on the lateral side, and connect them to the [BL] and [OPW] connectors of the Station.

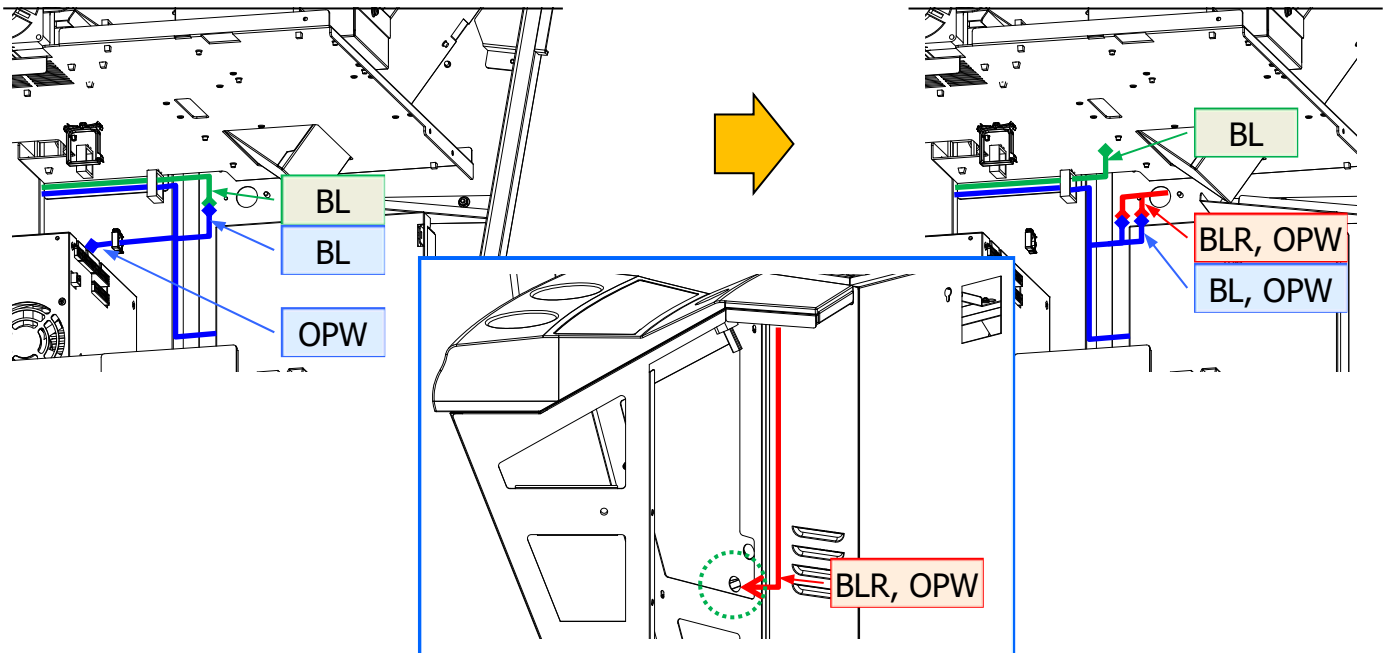

### 3. 2. 2: Installing Other Stations and Connecting to Center Unit

1. Prepare the following Parts.

Parts Name	Qty	Appearance
LAN Cable(for Station: 2.5m)	1	

2. Connect [LAN] cable to the Port of the HUB, and thread it as illustrated below.

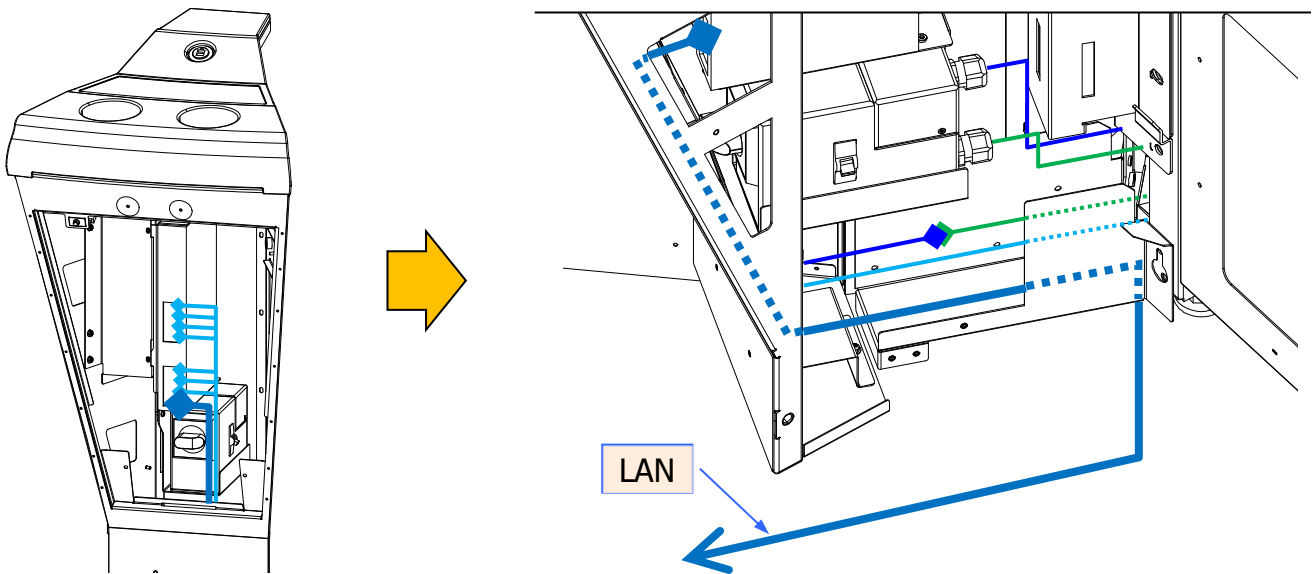

**i NOTE: Option-**[In case it is planned to extend the number of stations]

Connect in advance the [LAN] Cables for the Extension Stations, to the Switching Hub (Refer to **[Limitation for extension]** at 3.2). Then pull the [LAN] Cable from the [Pow Switch and HUB Spacer Unit] and arrange it so that it will not get in the way of the installation procedures

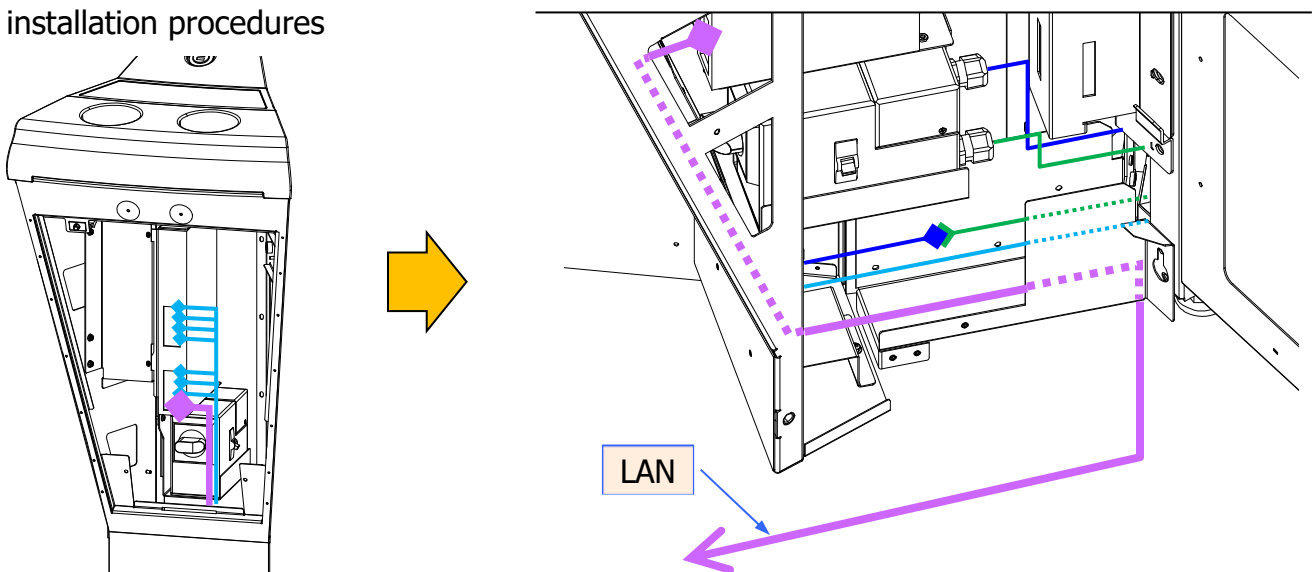

3. Prepare the following Parts.

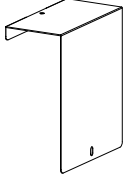
Parts Name	Qty	Appearance
Harness Cover	1	

4. Affix the Harness Cover to the Harness BRKT by using 2 screws, while paying attention not to pinch the Cables.

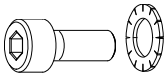
	Fasteners	Qty	Appearance
C	HEXAGON SOCKET M4x10 DIN 912 SERRATED LOCK WASHER 4 DIN 6798	2	

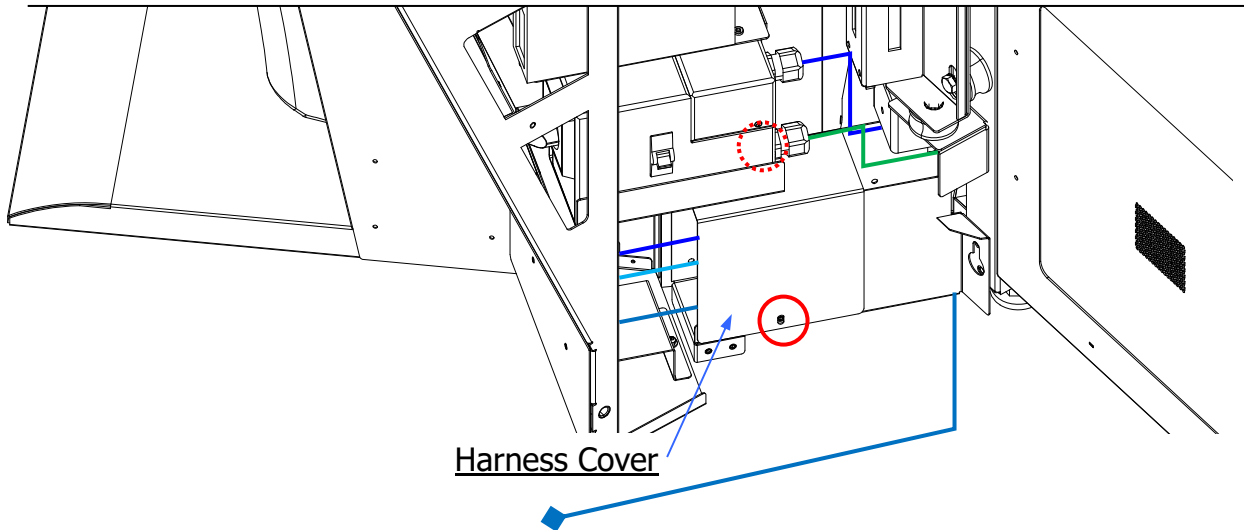

5. Move the [Station8 Unit] closer to side labelled by the sticker [STATION No.08].

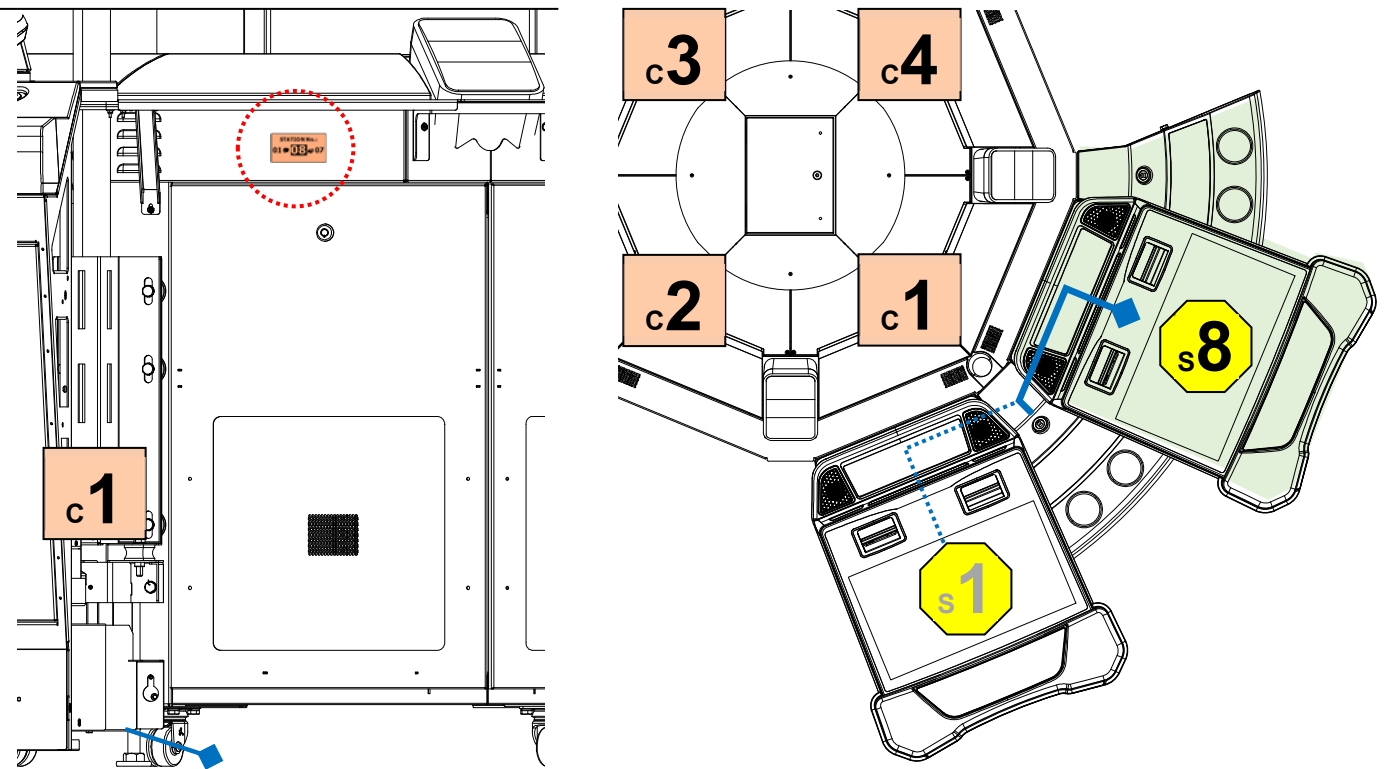

6. Insert the [LAN] Cable moved at STEP 2 , at the bottom of the rear side of the [STATION No.08].

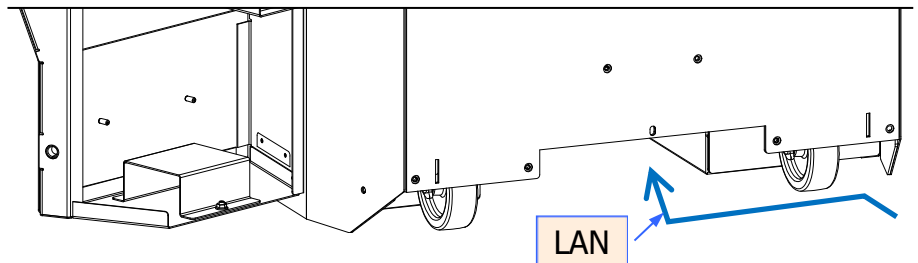

**i NOTE: Option-[If using a USB Charger]**

Insert the AC Adapter of the AC Cable for the USB Charger, at the bottom of the rear side of the Station.

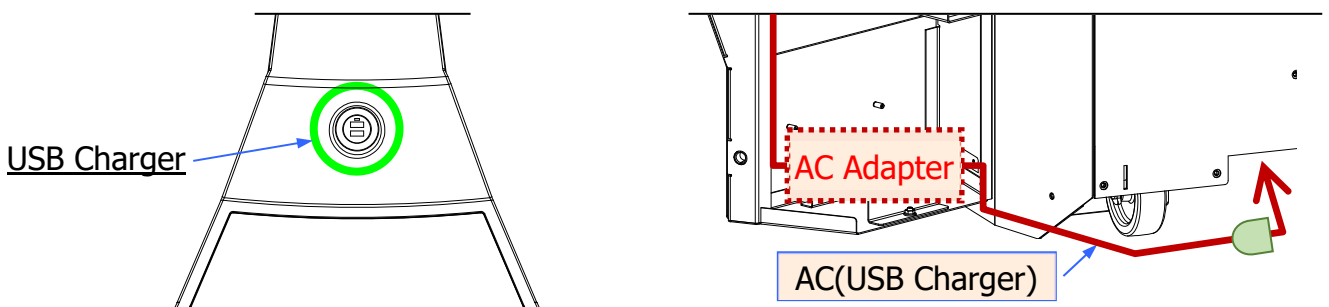

7. Remove 1 screw and detach the Bottom Cover on station.

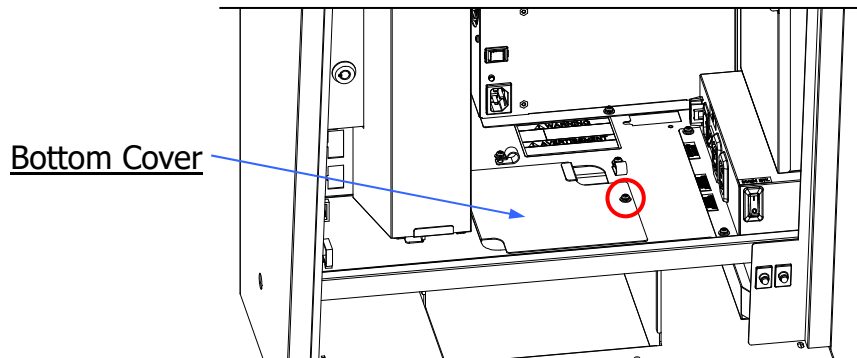

8. Unlock the Security Cage Front Cover and connect the [STATION 08] LAN Cable to the [LAN 2] Port indicated below.

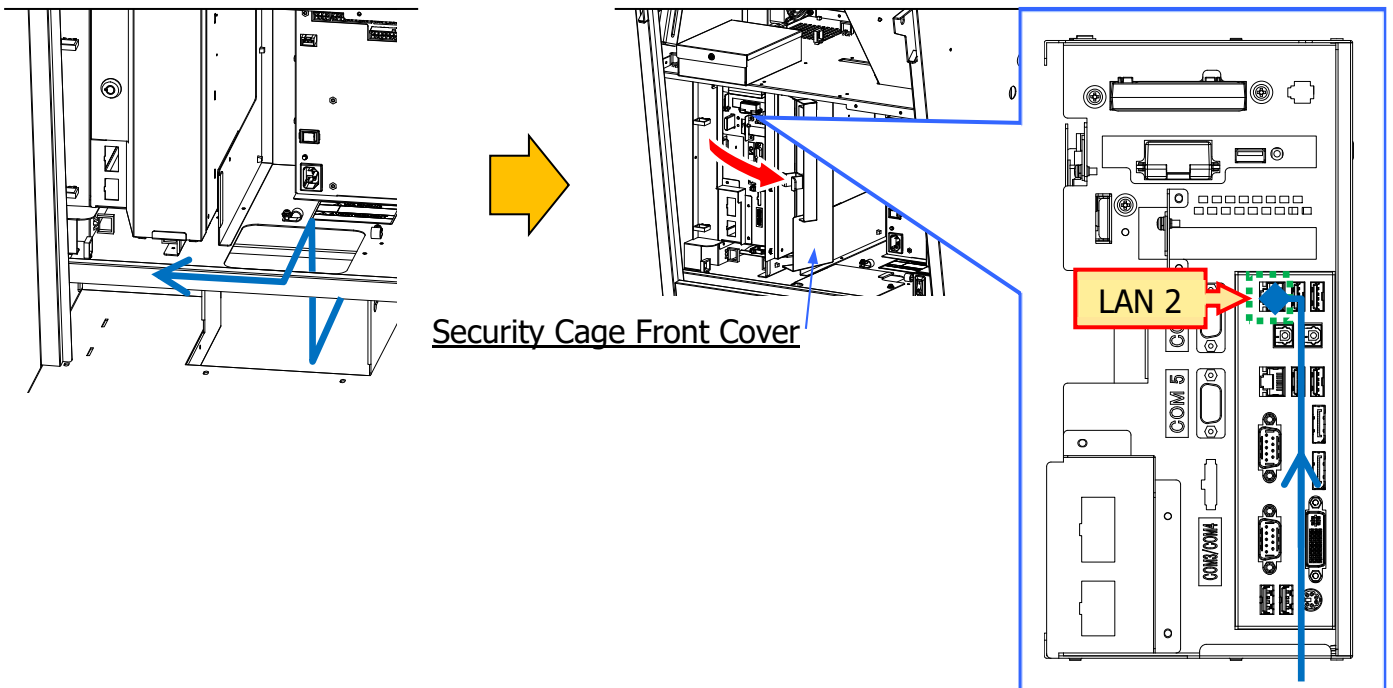

9. Move the [Station 7 Unit] closer to side labelled by the sticker [STATION No.07].

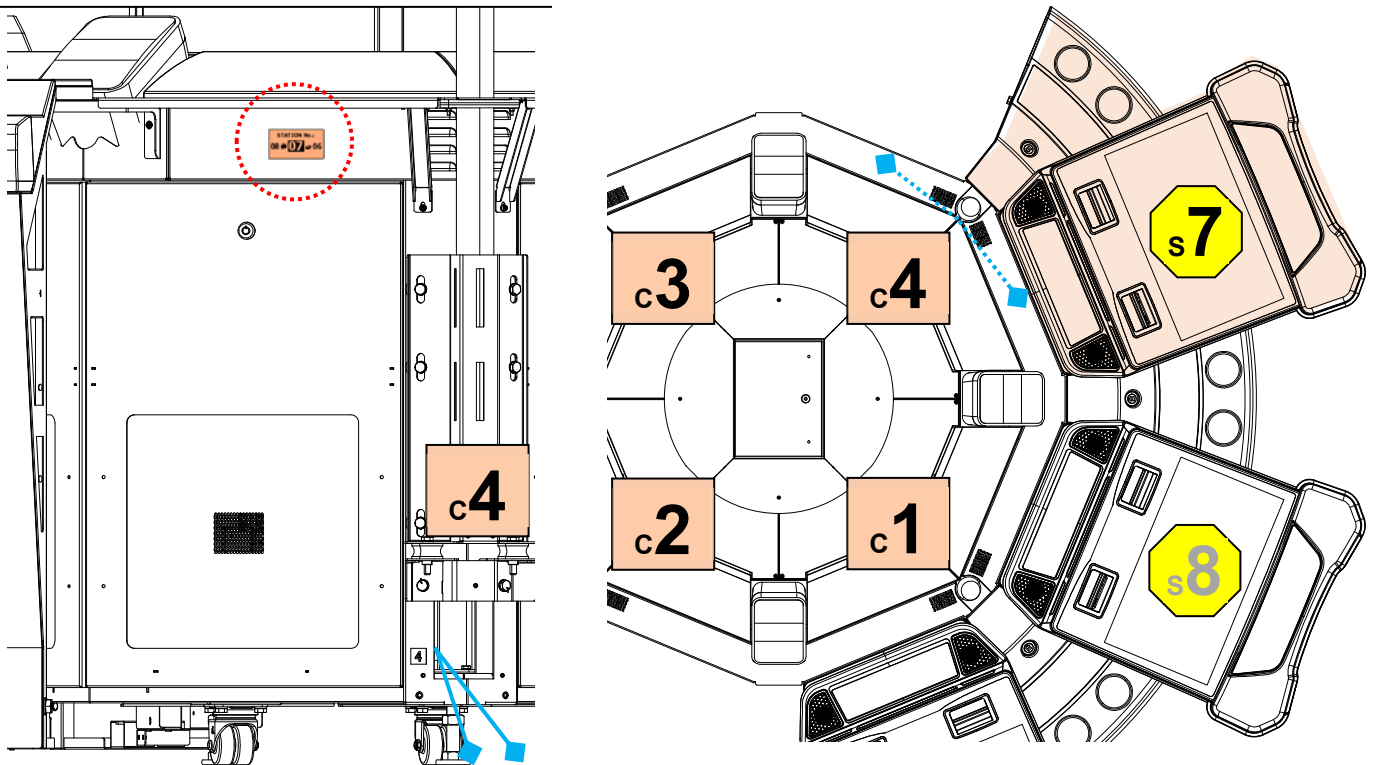

10. Insert the [STATION 07] LAN Cable (Refer to STEP 3 of 3.2.1.8), at the bottom of the rear side of the [STATION No.07].

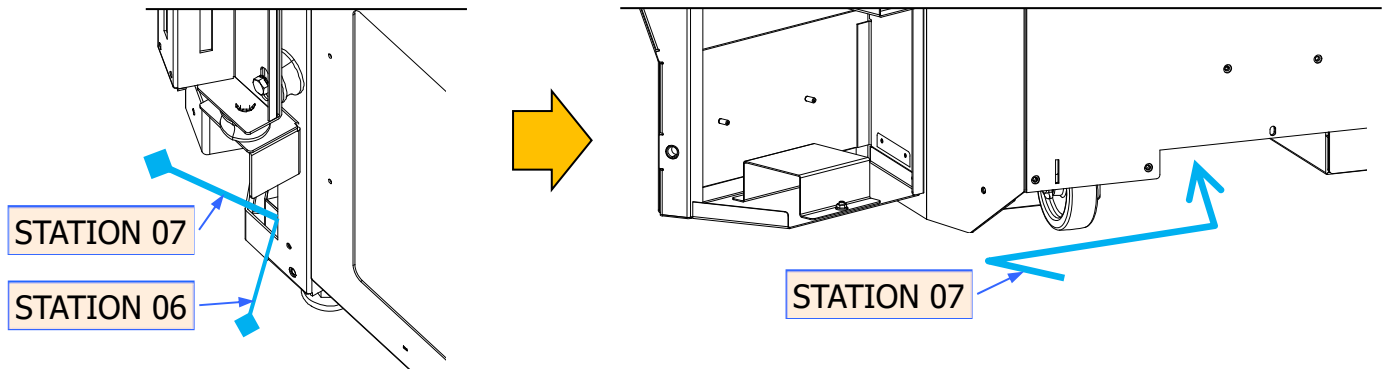

**i NOTE: Option-[If using a USB Charger]**

Insert the AC Adapter of the AC Cable for the USB Charger, at the bottom of the rear side of the Station.

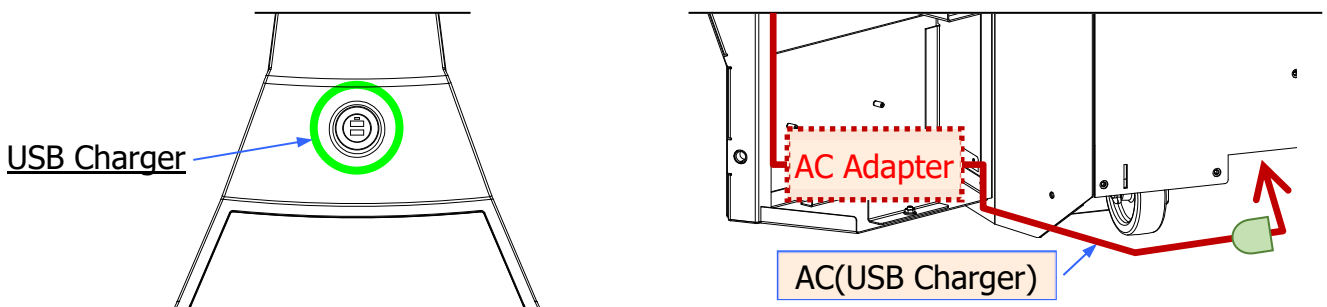

11. Remove 1 screw and detach the Bottom Cover on station.

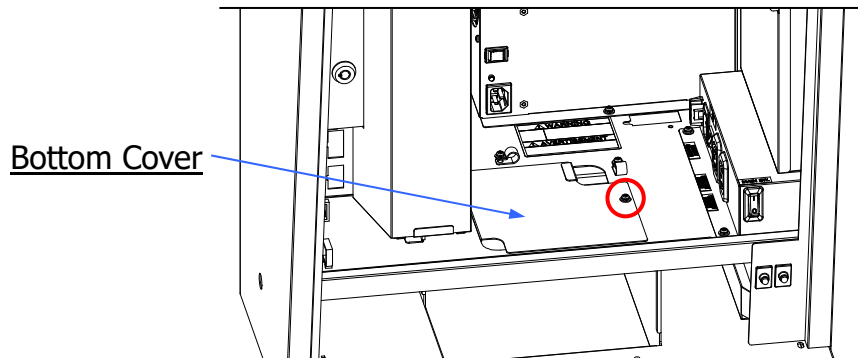

12. Unlock the Security Cage Front Cover and connect the [STATION 07] LAN Cable to the [LAN 2] Port indicated below.

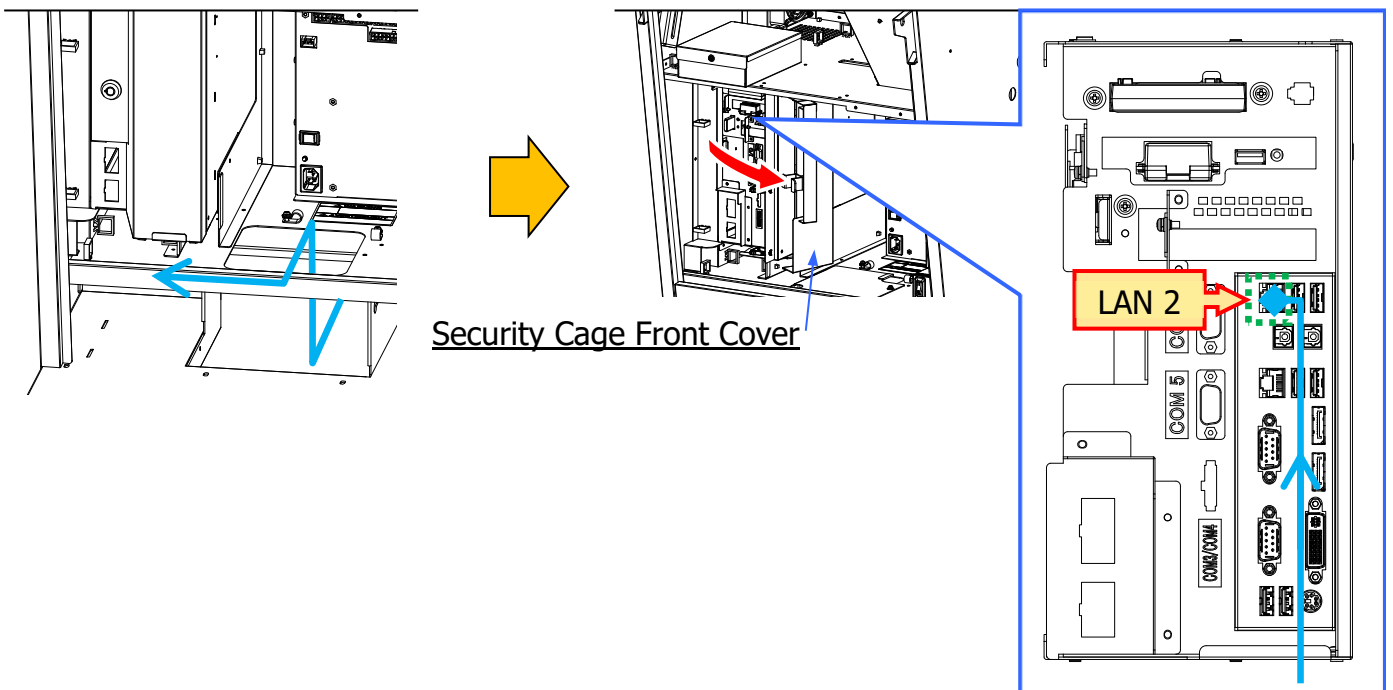

13. Repeat the same procedure by installing the respective Station Units on the side of the Center Unit with the stickers [STATION No.06], [STATION No.05], [STATION No.04] and [STATION No.02] and connect the [LAN] Cable to each of them.

### Station Layout Chart

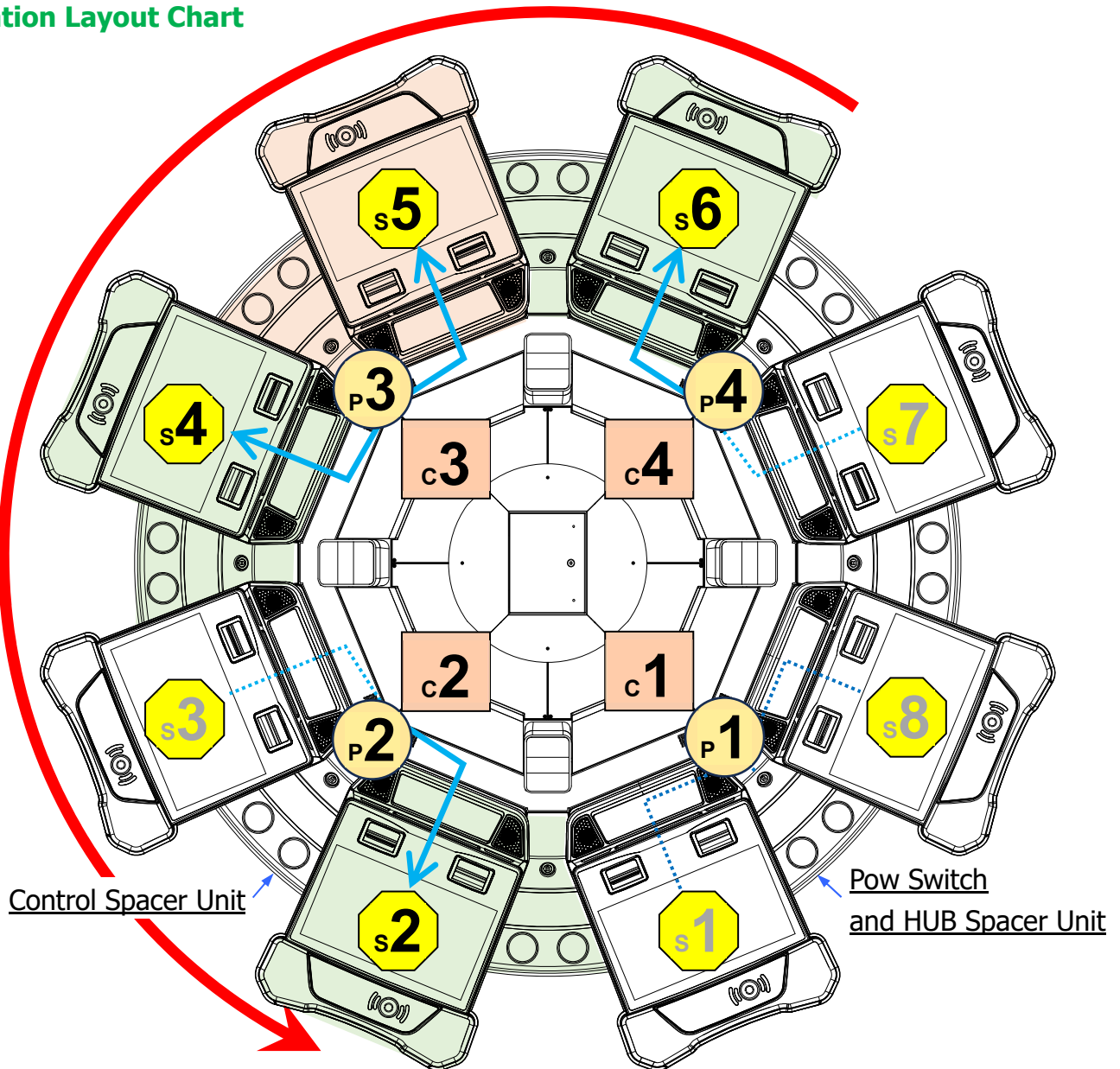

**i NOTE: Option-[If using a USB Charger]**

Insert the AC Adapter of the AC Cable for the USB Charger, at the bottom of the rear side of the Station.

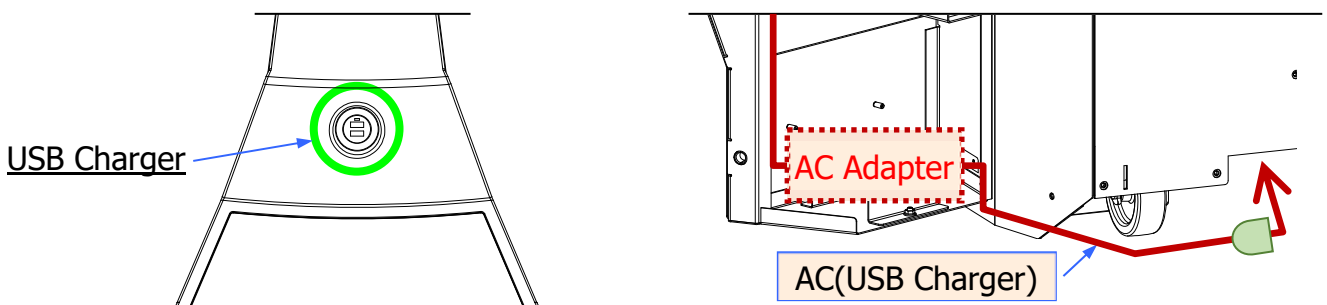

14. Affix each station to the Spacer Unit immediately on the left, by using 2 bolts.

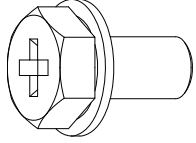
Fasteners		Qty	Appearance
E	HEX UPSET M10 x 20 3P	16	

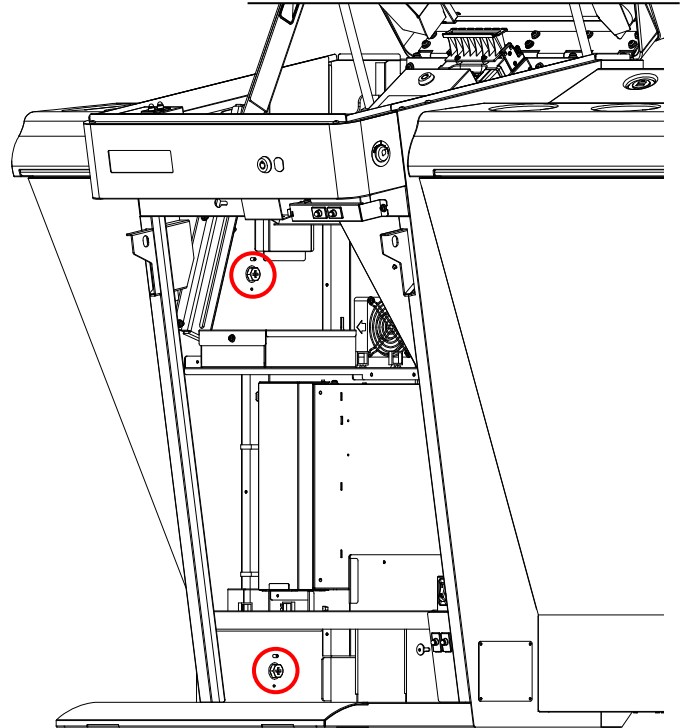

**i NOTE:** [In case it is planned to extend the number of stations]  
 Complete in advance the installation of all the Extension Stations. Connect the [LAN] Cables for Extension Stations use, that were connected to the Switching Hub of the Center Unit (**Refer to 3.2.2.2**), to the Extension Stations (or to the Hub connected to that).

### 3. 2. 2. 3: Hardware Setting for Station Unit

Hardware Settings are necessary for factory shipped products to be operational. Before commencing with operation, make sure to do the settings explained below.



#### **WARNING!**

Electrostatic discharge may damage internal components. When accessing the inside of the Cabinet, take anti-static measures (as wearing anti-static wrist band etc.) before proceeding.



#### **CAUTION!**

Hardware Settings must be done by authorized personnel.  
Once Hardware Settings are updated, all the Software Meters will be cleared to zero.  
Make sure to take note of all necessary Software Meters before updating.

**- Location of PCBs -**

The PCBs that require setting are shown below inside a frame.

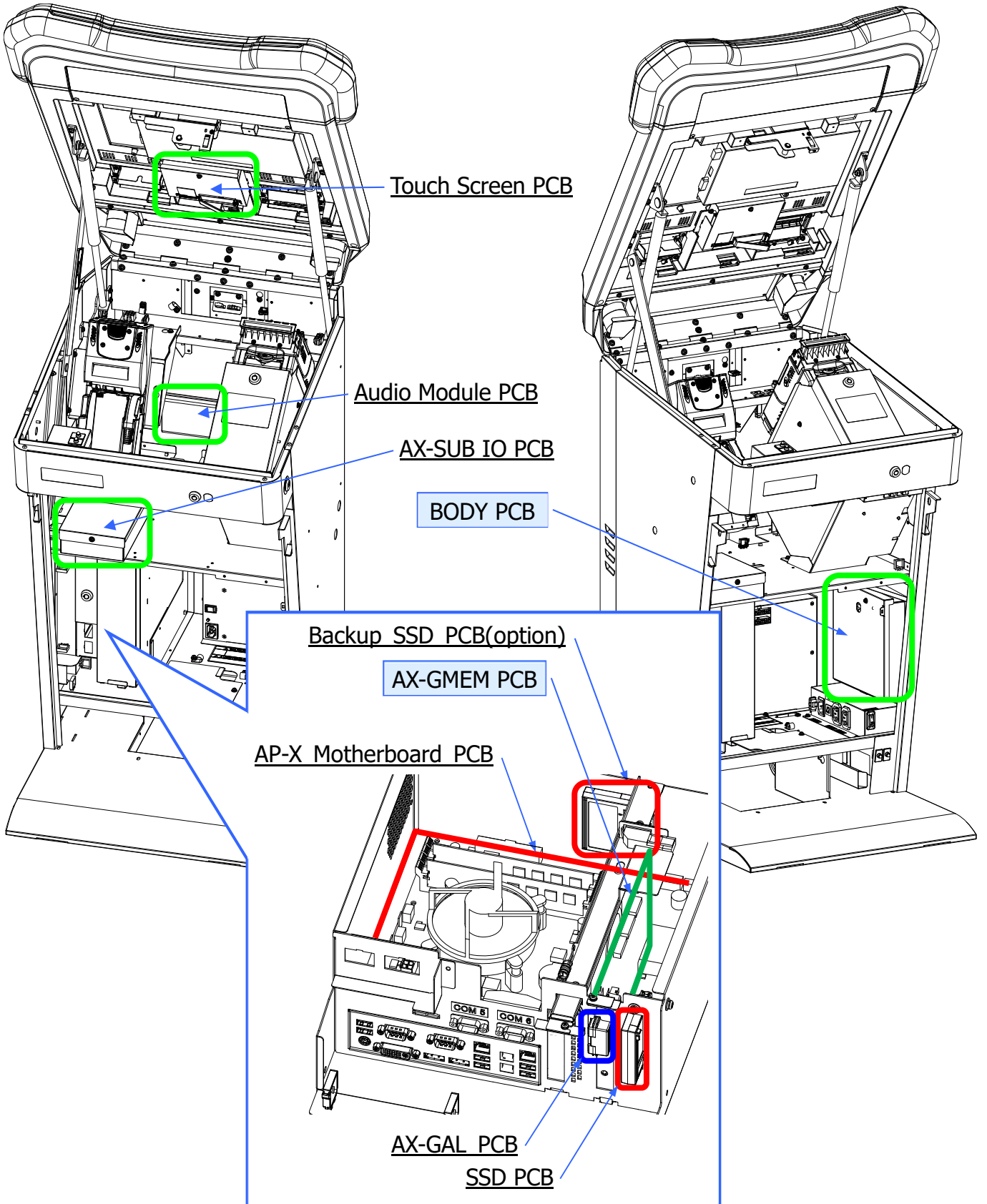

**- AX-GMEM PCB -**

PCB	Onboard Switch/Jumper	Factory Setting	Setting for Operation	Description
AX-GMEM PCB	S2 (Slide Switch)	Front (Battery OFF)	Back (Battery ON)	The switch for Backup Battery ON-OFF

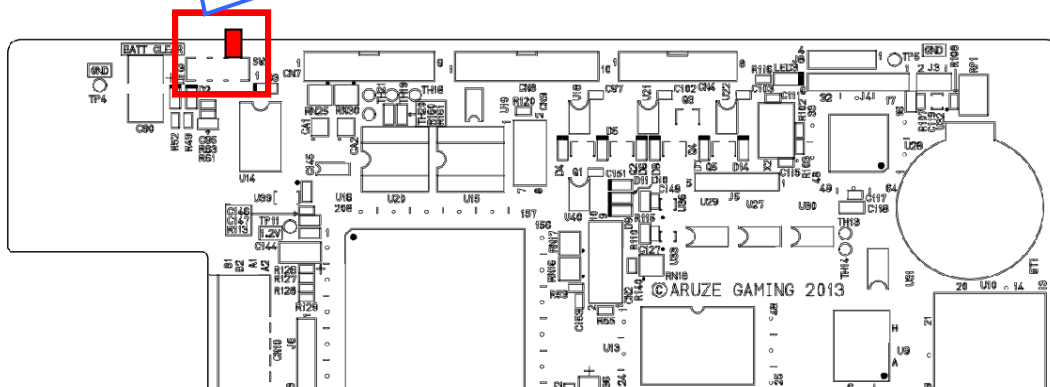
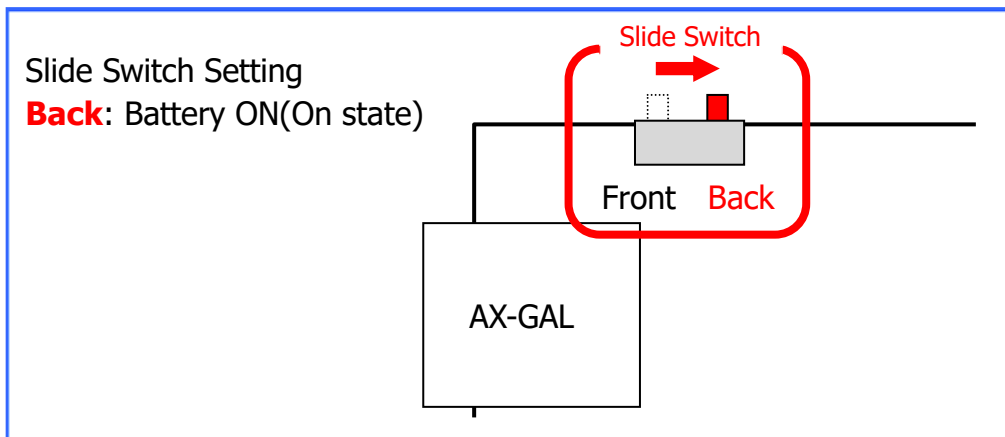
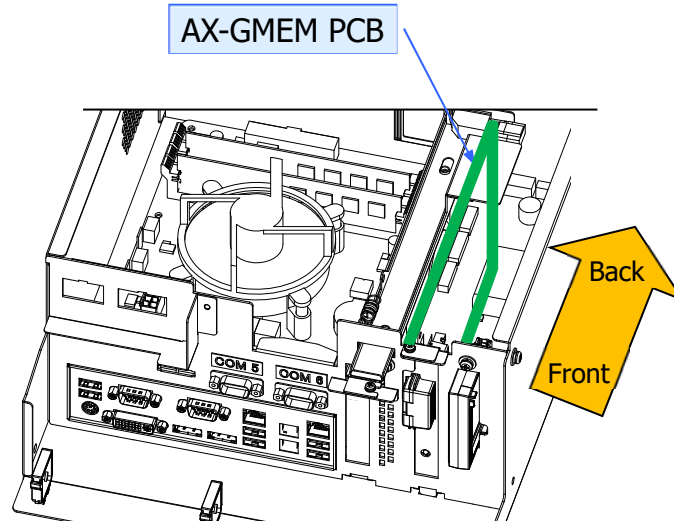

**- BODY PCB -**

PCB	Onboard Switch/Jumper	Factory Setting	Setting for Operation	Description
BODY PCB	SW2(2 Bit Dip Switch)	All OFF (Invalid)	All ON	The switch for enabling the Backup Battery

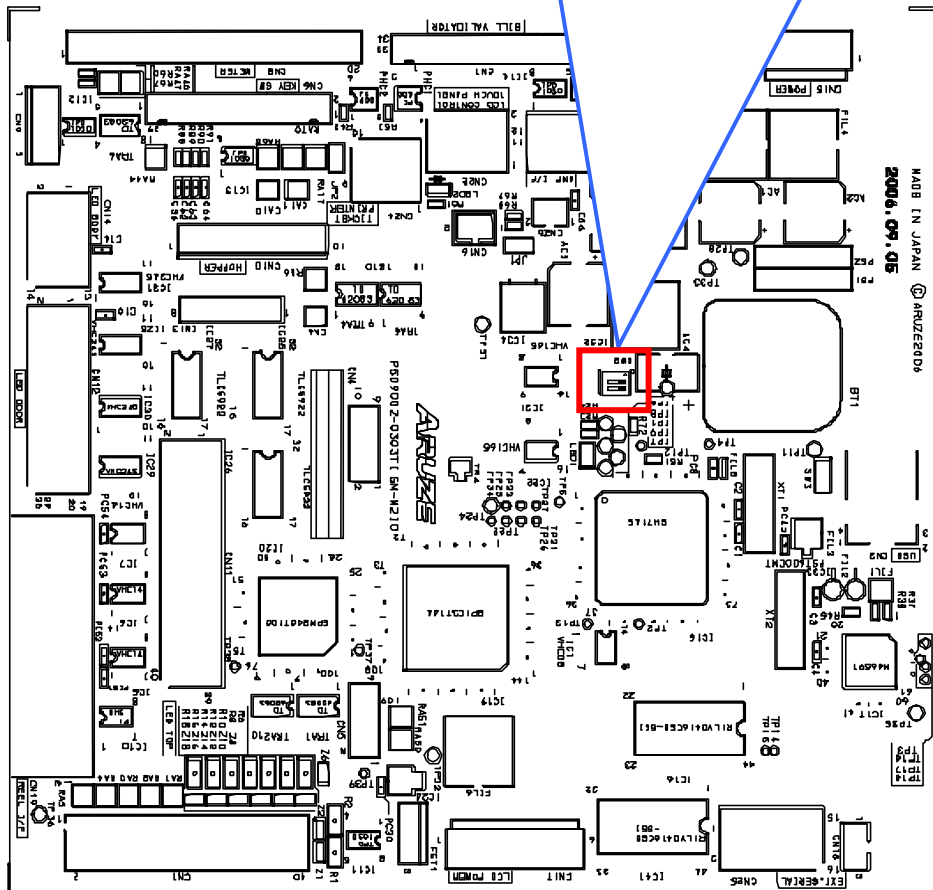
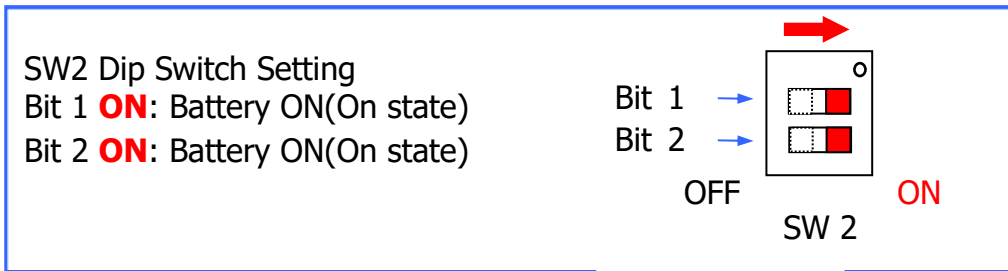
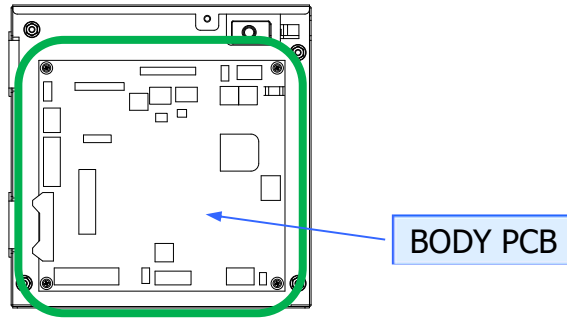

### 3. 2. 2. 4: Connecting the Stations to the Power Source

1. Make sure that the Power Switch of each Station is set to OFF.

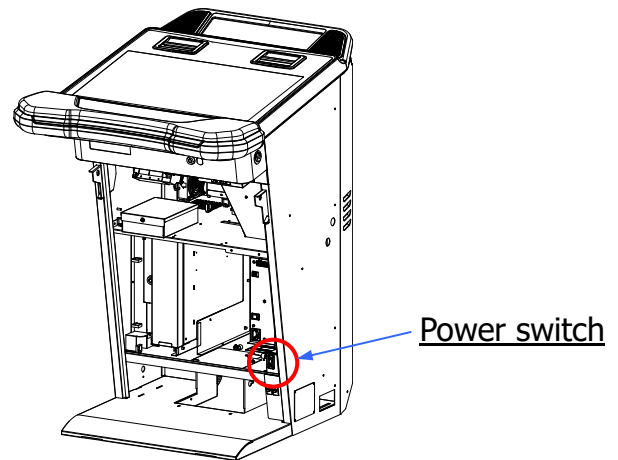

2. Prepare the following Parts.

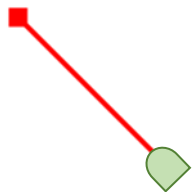
Parts Name	Qty	Appearance
AC Cable(for Station)	8	

3. Connect the Plug-in Unit (AC Base) and the Power receptacle of each station to the AC Cable. If a USB Charger is connected, when installing each Station plug also the AC (USB Charger). Arrange the cables installed so that they will not be an obstacle to the further procedures.

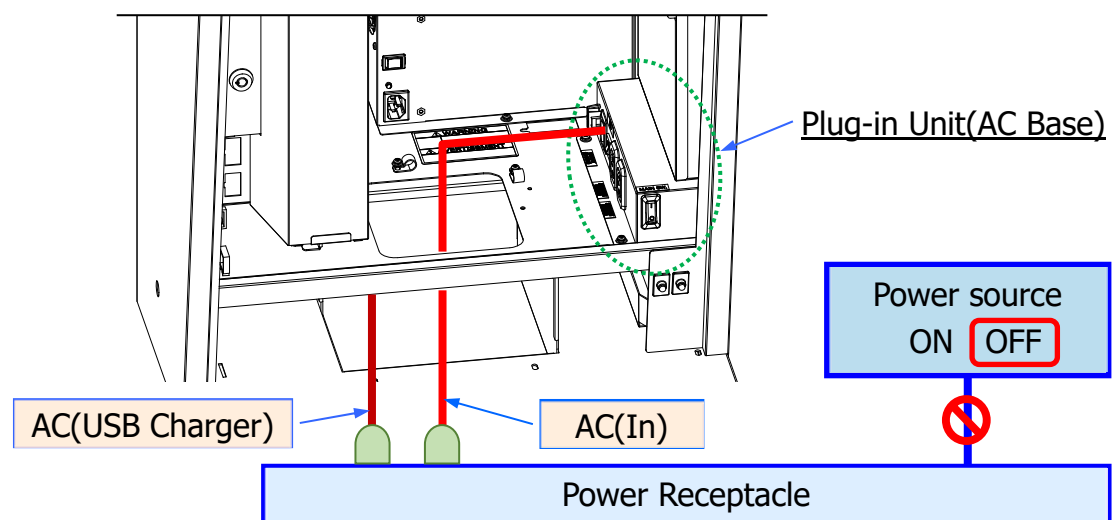

- Return the Bottom Cover and the Bottom Door of each Station to its previous position.

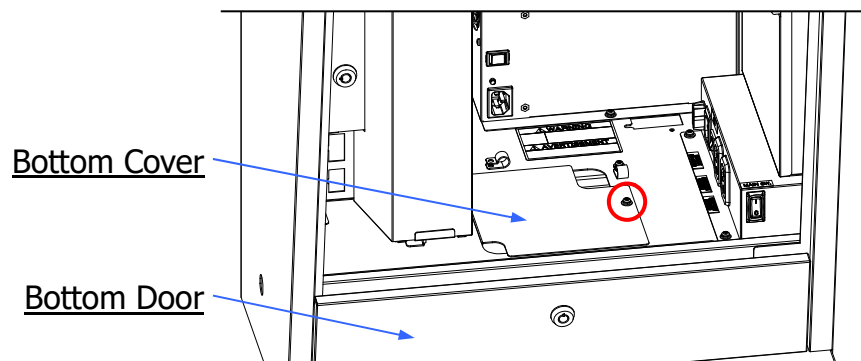

- This completes the connection to the Power Source of each Station.

### 3. 2. 3: Checking and Setting

**i NOTE: Option-**[In case it is planned to extend the number of stations]  
Continue the procedure after the installation of all the Extension Stations is complete.

Before turning ON the Center Unit and the Stations, check the following;

- All the cable connectors are securely seated.
- The machine is properly earthed.

#### 3. 2. 3. 1: Preparation to set the Stations

**! CAUTION!**  
Stations power should be OFF at this stage.

**i NOTE:**  
The check for the operation functionality of the Center Unit has already been completed at "**Checking Operation of the Center Unit**", therefore from now it will be performed only a check for the Stations.

1. First turn ON the power source. The devices directly connected to the power source will boot up.

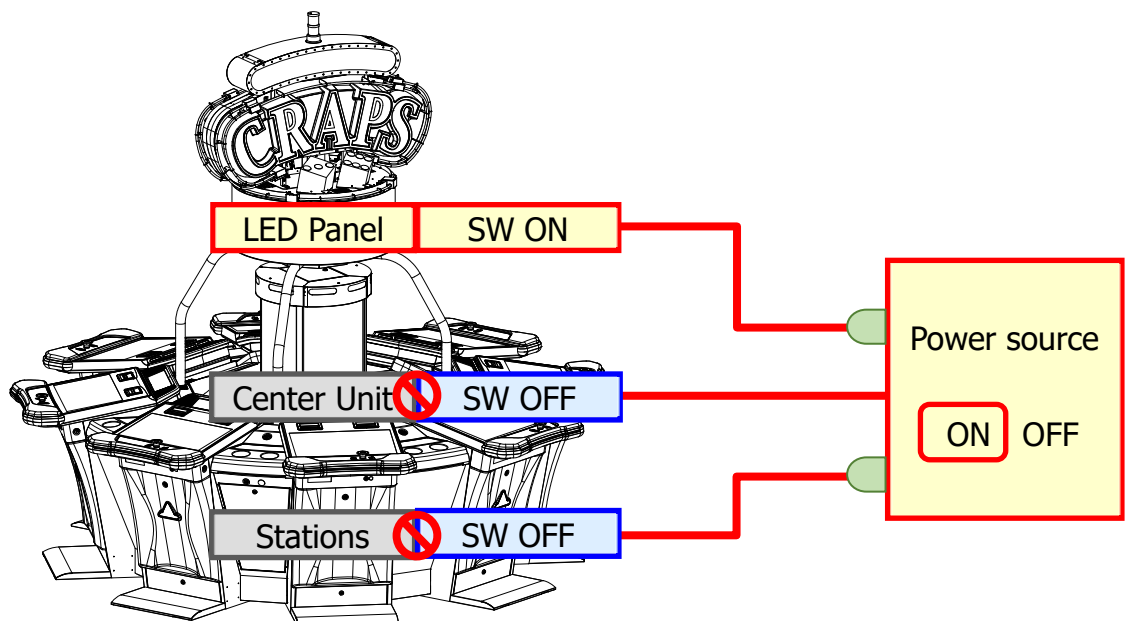

2. Turn to ON the Power Switch of the Center Unit.

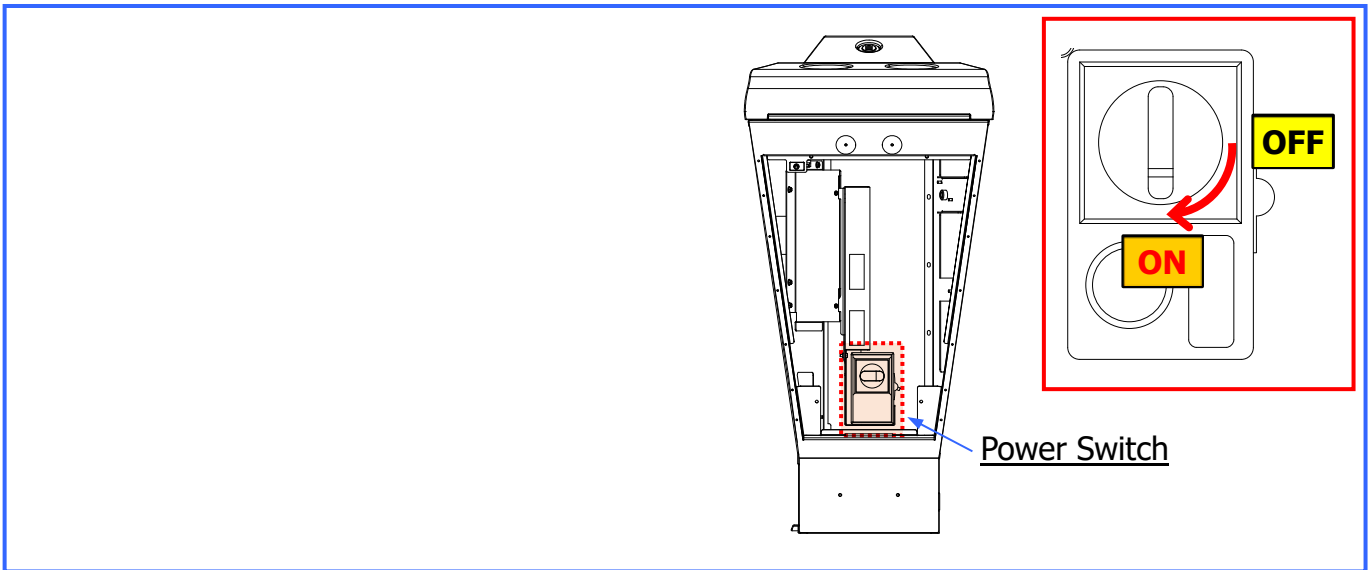

**CAUTION!**

When doing "Power OFF-ON" wait at least 15 seconds before power On.

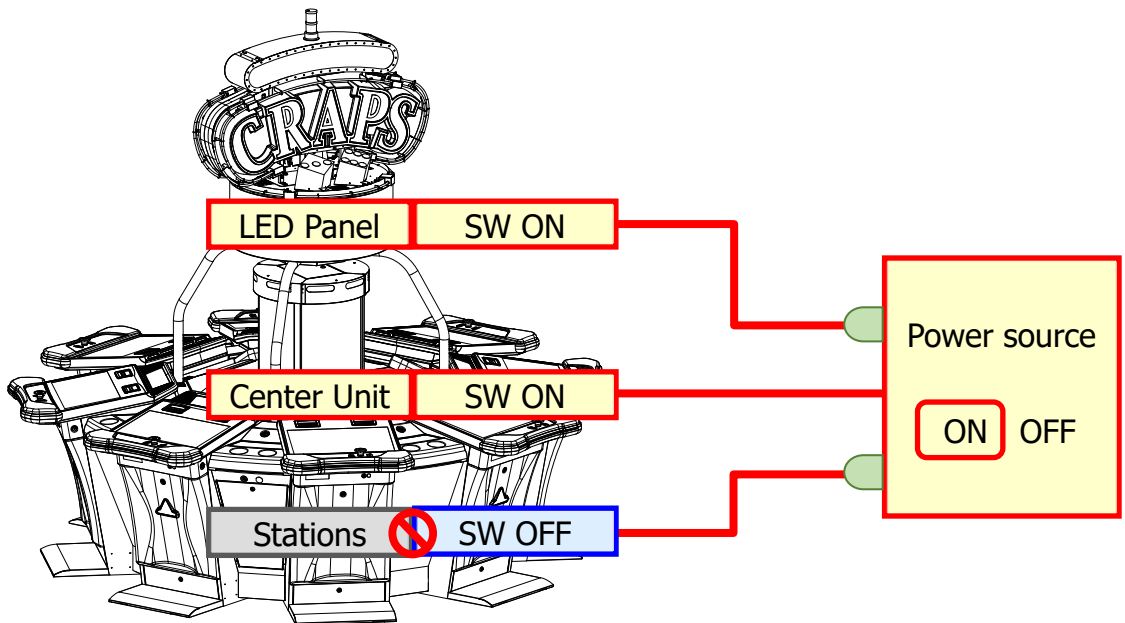

### 3. 2. 3. 2: Setting operation of Stations

1. Open the Security Cage Front Cover of each of the 8 Stations that are installed around the Center Unit.

#### CAUTION!

- A Station that is booted up for the first time after it was connected to the Center Unit, first needs the setting of the [STATION ID NUMBER].
- Skip the following procedure up to STEP 7 if the [STATION ID NUMBER] was already set before the shipping of the machine.

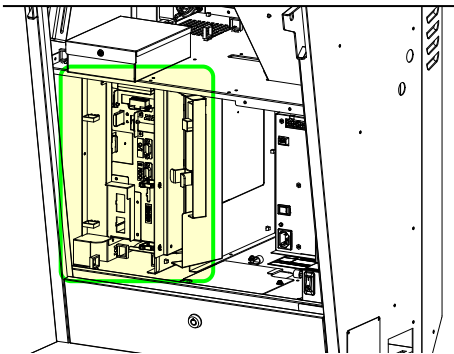
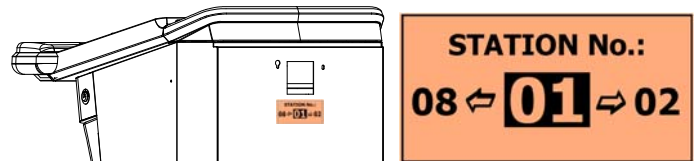

2. Turn ON the Power Switch of only 1 Station.

#### CAUTION!

- Perform the setting one station at time.
- Do not boot on other stations before the [STATION ID NUMBER] is set.
- When doing "Power OFF-ON" wait at least 15 seconds before power On.
- Do not touch the Touch Screen when [NOW CHECKING] is displayed. This may lead to Touch Screen malfunction.

#### NOTE:

- If it is necessary to perform the RAM Clear (Memory Clear), refer to "**Memory Clear Procedure**" on Chapter 7 of the SERVICE Manual.
- If an error appears during the POWER UP SELF TEST, the activation of the Machine halts. Refer to OPERATION Manual Chapter 8 "**Error Messages**" to clear it.
- When the machine was shipped, the touch Screens were calibrated. However, if needed, calibrate the touch Screens by referring to our Service Manual.

- ◇ Are there any strange sounds or smells coming from the machine?
- ◇ Test the proper functionality of Sensors, RESET/AUDIT key switches etc.

- To call the AUDIT mode, turn the key to the AUDIT position, and return it to the neutral position.



- Refer to "**Version Information**" at Chapter 7 of the OPERATION Manual, to check that the Software version is the same as the Software Version approved for installation.
- Refer to "STATION ID NUMBER" on "**Important Settings / Basic Settings**" at Chapter 5 of the SERVICE MANUAL, to set the [STATION ID NUMBER].

**i NOTE:**

Check the [STATION ID NUMBER] at [\[Station Layout Chart\]](#) (Refer to 3.2.2.2).

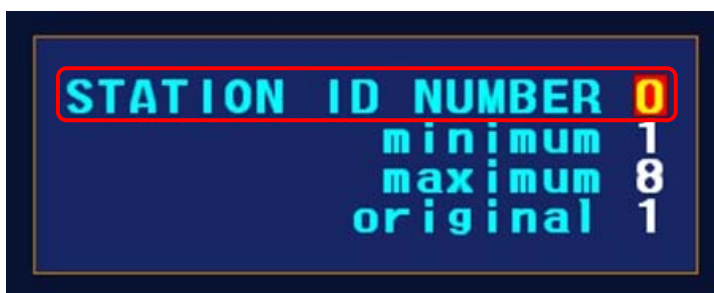

- When settings are complete, press [Exit] or [RETURN TO...] on the menu screen.  
When the following message appears: [Touch [YES] to SAVE the Update. to CANCEL the Update, touch [NO].], press [YES].  
When the [Turn OFF and ON the machine to make the Update effective.] message appears, turn OFF the machine.

**i NOTE:**

After the Power OFF (Save the settings) of the Station, it is possible to Power ON the following one. Repeat the same procedure for all the stations, while paying attention not to set twice the same number.

7. Turn ON the Power Switch of the Station, check that the [TERMINAL No.] at the top of the screen displays the same value set as [STATION ID NUMBER].

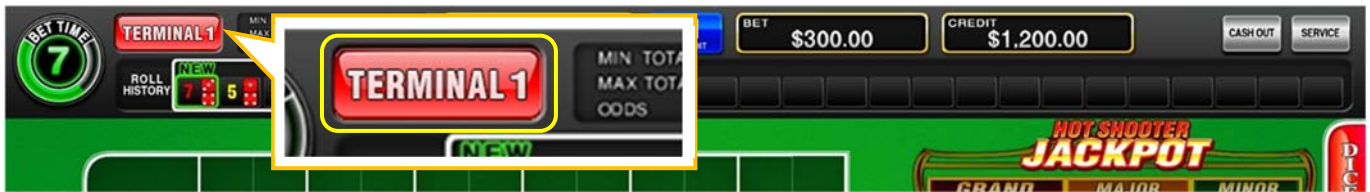

**i NOTE:**

- If it is necessary to perform the RAM Clear (Memory Clear), refer to **“Memory Clear Procedure”** on Chapter 7 of the SERVICE Manual.
- If an error appears during the POWER UP SELF TEST, the activation of the Machine halts. Refer to OPERATION Manual Chapter 8 **“Error Messages”** to clear it.
- When the machine was shipped, the touch Screens were calibrated. However, if needed, calibrate the touch Screens by referring to our Service Manual.

- ◇ Are there any strange sounds or smells coming from the machine?
  - ◇ Test the proper functionality of Sensors, RESET/AUDIT key switches etc.
8. To call the AUDIT mode, turn the key to the AUDIT position, and return it to the neutral position.

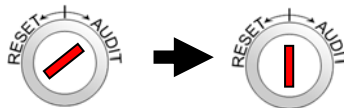

9. Refer to **“Version Information”** at Chapter 7 of the OPERATION Manual, to check that the Software version is the same as the Software Version approved for installation.
10. Refer to **“Settings”** on Chapter 5 of the SERVICE Manual to configure the necessary settings.
11. When settings are complete, press [Exit] or [RETURN TO...] on the menu screen. When the following message appears: [Touch [YES] to SAVE the Update. to CANCEL the Update, touch [NO].], press [YES].  
When the [Turn OFF and ON the machine to make the Update effective.] message appears, turn OFF the machine.
12. Close the Security Cage Front Cover and turn ON again the Power Switch of the Station.



**CAUTION!**

When doing “Power OFF-ON” wait at least 15 seconds before power On.

13. Refer to **"Output Test"** at Chapter 5 of the SERVICE Manual, to check if the illuminations are lit correctly.
14. Exit the AUDIT and close the Front Door. Press the GAME RULES button on the Station several times, and check if the BGM plays correctly.

**i NOTE: Option-**[In case it is planned to extend the number of stations]

Set also the [STATION ID NUMBER] of the additional Stations by following the same procedure and paying attention not to repeat the same number.

If the [maximum] is different from the total number of Stations, including the Expansion Stations, set again [NUMBER OF STATIONS] on the Center Unit. **(Refer to 3.2.1.12)**

#### Station AUDIT

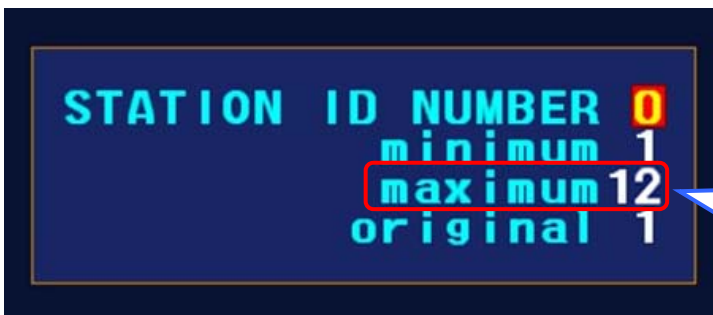

#### Center Unit AUDIT

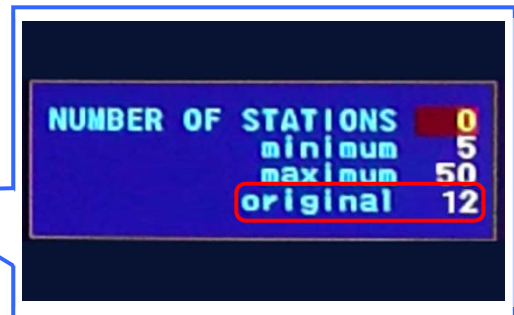

### 3. 2. 3. 3: Verifying Operation of Whole Machine

1. Verify on each Station that BILLS(NOTES)/Tickets are correctly counted by inserting BILLS(NOTES)/Tickets.
2. Play on each Station 10 games on the installed stations to check if the game normally proceeds.

Appearance of the completed machine.

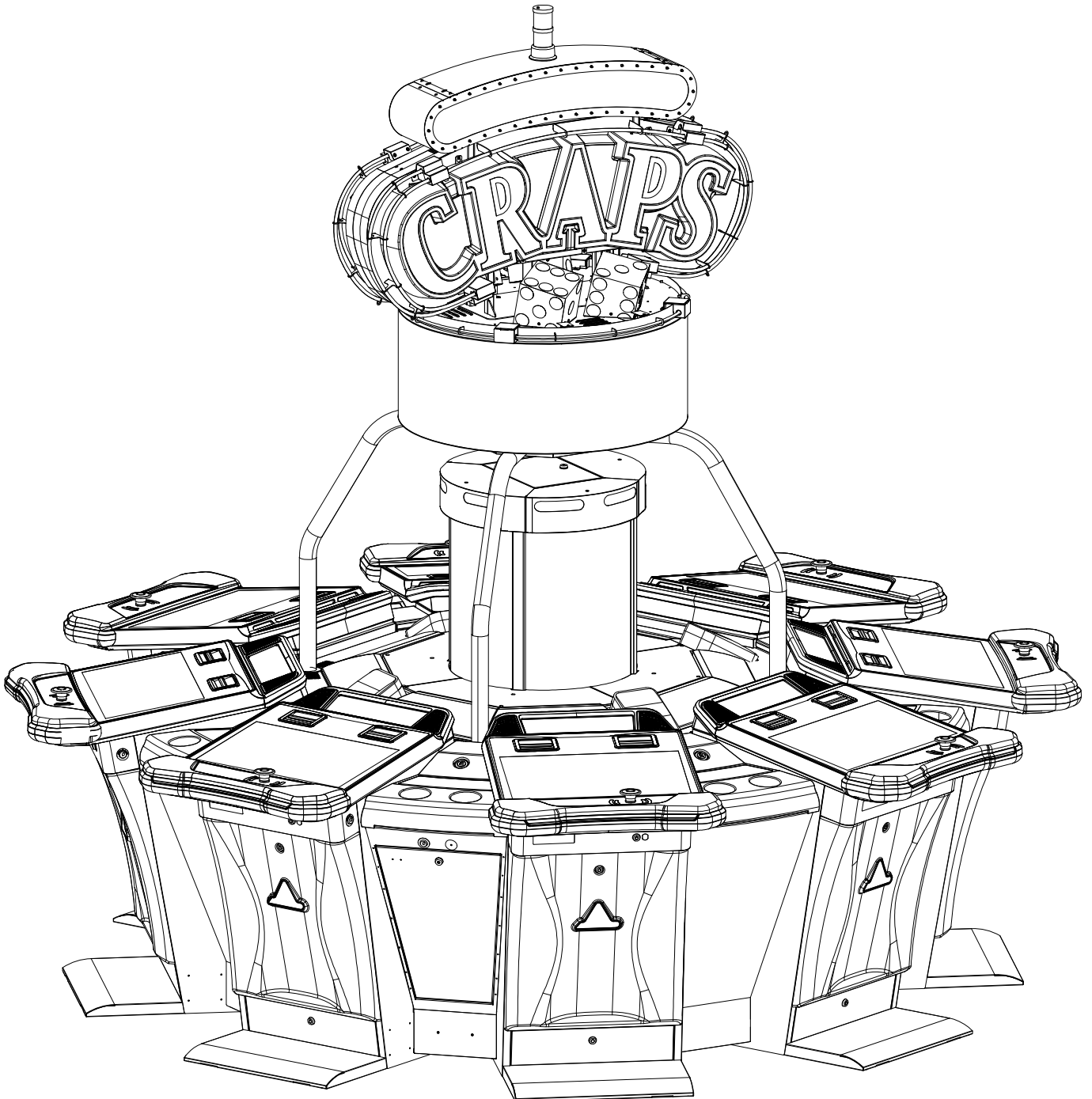



## Chapter 4

### Machine Specifications

#### 4. 1: Cabinet Code(MODEL#)

Center Unit: PTWDG01

Station: AXPS01

#### 4. 2: Overall Dimension

	Width	Height	Depth
Whole Machine Including 8pcs Stations layout Excluding Tower Light	3050 mm (120.08")	2695 mm (106.10")	3050 mm (120.08")
Station : Excluding Back LED Unit	670 mm (26.38")	972 mm (38.27")	810 mm (31.89")
: Including Back LED Unit			868 mm (31.17")

#### 4. 3: Weight

Center Unit	364 kg(802.5 lbs)
Station	90 x8 kg(1587.3 lbs)
Pow Switch and HUB Spacer Unit	12 kg(26.5 lbs)
Control Spacer Unit	20 kg(44.1 lbs)
Spacer Unit	10 x6 kg(132.3 lbs)

## 4. 4: Electrical Specifications

### Center Unit: PTWDG01

#### Power Requirements

<b>Input Voltage</b>	100 - 120VAC	220 - 240VAC
Input Frequency	50 / 60Hz	50 / 60Hz
<b>Mains Input Current</b>		
EGM Maximum (* Including Service Outlet)	5.8 A	3.5 A
EGM Typical	4.8 A	2.5 A
<b>Power Consumption at Nominal Voltage</b>		
EGM Typical	576 W	576 W
Typical Heat Load	1965 BTU/hr	1965 BTU/hr
<b>Maximum Load Current</b>		
Service Outlet	<b>N/A</b>	<b>N/A</b>
<b>Power Consumption at Nominal Voltage</b>		
EGM Maximum (excluding Service Outlet)	Maximum allowed by PSU	Maximum allowed by PSU

### Station: AXPS01

#### Power Requirements

<b>Input Voltage</b>	100 - 120VAC	220 - 240VAC
Input Frequency	50 / 60Hz	50 / 60Hz
<b>Mains Input Current</b>		
EGM Maximum (* Including Service Outlet)	4.7 A	3.7 A
EGM Typical	1.0 A	0.6 A
<b>Power Consumption at Nominal Voltage</b>		
EGM Typical	119 W	118 W
Typical Heat Load	404 BTU/hr	401 BTU/hr
<b>Maximum Load Current</b>		
Service Outlet	1A x 2	1A x 2
<b>Power Consumption at Nominal Voltage</b>		
EGM Maximum (excluding Service Outlet)	Maximum allowed by PSU	Maximum allowed by PSU

**4. 5: Environment**

Ambient temperature	0 through 40 degrees C
Ambient humidity	5 through 95% Free from dew condensation

**4. 6: BILLS Capacity**

Maker : Model	Capacity
JCM : UBA / i VIZION / i PRO	500 – 900 BILLS
Cash Code : CASH CODE ONE	600 – 900 BILLS
MEI : CASHFLOW	600 – 1200 BILLS





**Customer Technical Support Available 24 hours a day/ 7 days a week**

TEL: USA, Canada, Latin America, Asia-Pacific: +1 877 676 7711  
Europe, Middle East and Africa: +386 51 305 111  
FAX: +386 1 724 77 44  
EMAIL: [call.center@interblockgaming.com](mailto:call.center@interblockgaming.com)  
WEB: [www.interblockgaming.com/service](http://www.interblockgaming.com/service)

**Australia**

**Interblock Asia & Pacific Pty Ltd**

World Square Tower' Suite 4555 Level 45, 680 George Street, Sydney NSW 2000

**Canada**

**Interblock Canada Inc.**

#225 - 20316 56 Avenue, Langley, British Columbia, Canada V3A 3Y7

**Asia**

**Interblock Asia Pacific Pty Ltd – Macau Branch**

Avenida da Praia Grande, n. 325, Edificio Cheong Fai, 2 andar "B", Macau

**USA**

**Interblock Usa L.C.**

6900 S Decatur Blvd. Suite 100, Las Vegas, NV 89118, USA

**Latin America**

**Interblock Spain S.L. – Argentina Branch Regional Office Buenos Aires, Argentina**

Esmeralda 1320, Piso 6° Of. B, Buenos Aires 1007, Argentina

**Europe**

**Interblock D.O.O.**

Gorenjska cesta 23, 1234 Mengeš, Slovenia, Europe

**Japan**

**G.K. Interblock**

TS Tower, 4-12-3 Higashi-Shinagawa, Shinagawa, Tokyo, 140-0002 Japan